

# MP2109

## Dual 1.2MHz, 800mA Synchronous Step-Down Converter

The Future of Analog IC Technology

### DESCRIPTION

The MP2109 contains two independent 1.2MHz constant frequency, current mode, PWM step-down converters. Each converter integrates a main switch and a synchronous rectifier for high efficiency without an external Schottky diode. The MP2109 is ideal for powering portable equipment that runs from a single cell Lithium-Ion (Li+) battery. Each converter can supply 800mA of load current from a 2.5V to 6V input voltage. The output voltage can be regulated as low as 0.6V. The MP2109 can also run at 100% duty cycle for low dropout applications.

### EVALUATION BOARD REFERENCE

Board Number	Dimensions
EV2109DQ-00A	1.5"X x 1.0"Y x 0.5"Z

### FEATURES

- Up to 95% Efficiency
- 1.2MHz Constant Switching Frequency
- 800mA Load Current on Each Channel
- 2.5V to 6V Input Voltage Range
- Output Voltage as Low as 0.6V
- 100% Duty Cycle in Dropout
- Current Mode Control
- Short Circuit Protection
- Thermal Fault Protection
- <0.1 $\mu$ A Shutdown Current
- Internally Compensated
- Space Saving 10-Pin QFN Package

### APPLICATIONS

- Cellular and Smart Phones
- Microprocessors and DSP Core Supplies
- PDAs
- MP3 Players
- Digital Still and Video Cameras
- Portable Instruments

"MPS" and "The Future of Analog IC Technology" are Registered Trademarks of Monolithic Power Systems, Inc.

### TYPICAL APPLICATION

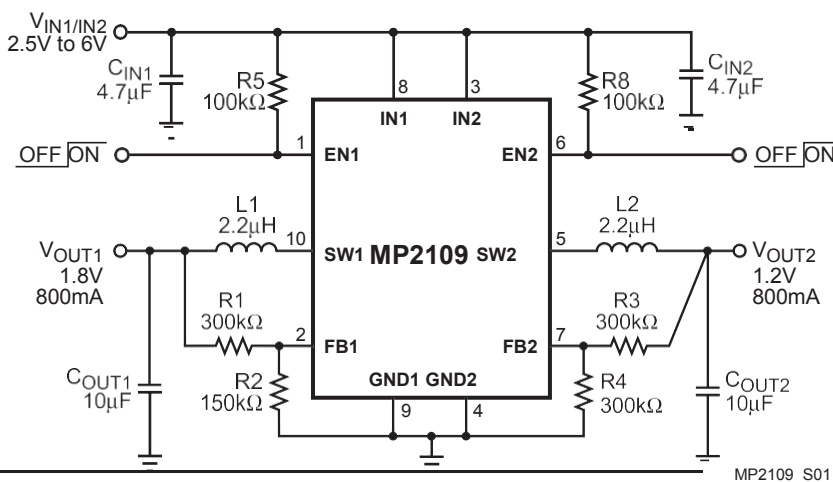

### Efficiency vs Load Current

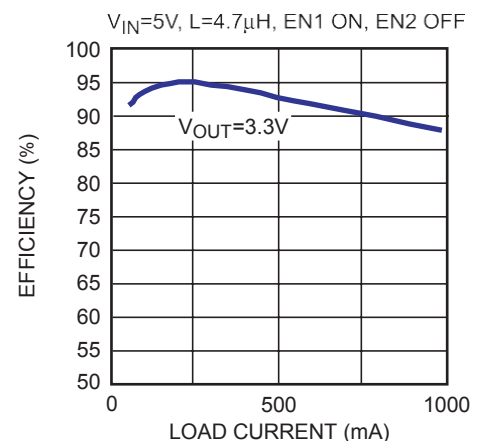

## PACKAGE REFERENCE

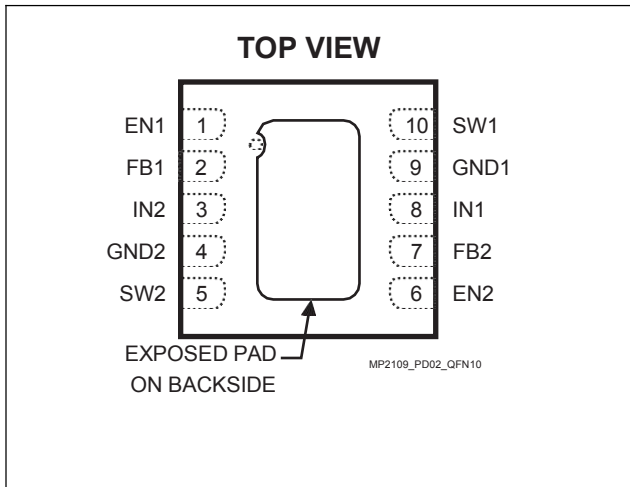

Part Number*	Package	Temperature
MP2109DQ	QFN10 (3mm x 3mm)	-40°C to +85°C

\* For Tape & Reel, add suffix -Z (eg. MP2109DQ-Z)  
For Lead Free, add suffix -LF (eg. MP2109DQ-LF-Z)

## ABSOLUTE MAXIMUM RATINGS <sup>(1)</sup>

$V_{IN1/IN2}$  to GND..... V to +6.5V  
 $V_{SW1/SW2}$  to GND..... V to  $V_{IN} + 0.3V$   
 $V_{FB1/FB2}$ ,  $V_{EN1/EN2}$  to GND..... V to +6.5V  
 Junction Temperature..... +150°C  
 Lead Temperature..... +260°C  
 Storage Temperature..... 65°C to +150°C

## Recommended Operating Conditions <sup>(2)</sup>

Supply Voltage  $V_{IN1/IN2}$  ..... 2.5V to 6V  
 Output Voltage  $V_{OUT1/OUT2}$ ..... V to 6V  
 Operating Temperature..... 40°C to +85°C

**Thermal Resistance <sup>(3)</sup>**      $\theta_{JA}$       $\theta_{JC}$   
 QFN10 (3mm x 3mm)..... 50..... 12... °C/W

## Maximum Power Dissipation <sup>(4)</sup> ( $T_A=25^\circ\text{C}$ )

QFN10 (3mm x 3mm).....  $P_D$ ..... 2.5..... W

### Notes:

- 1) Exceeding these ratings may damage the device.
- 2) The device is not guaranteed to function outside of its operating conditions.
- 3) Measured on JESD51-7 4-layer board.
- 4) Reduce 0.2 watts every 10°C increasing.

## ELECTRICAL CHARACTERISTICS <sup>(5)</sup>

$V_{IN1/IN2} = V_{EN1/EN2} = 3.6V$ ,  $T_A = +25^\circ\text{C}$ , unless otherwise noted.

Parameter	Symbol	Condition	Min	Typ	Max	Units
Each Converter Supply Current		$V_{EN1/EN2} = V_{IN1/IN2}$ , $V_{FB1/FB2} = 0.65V$		440	600	$\mu\text{A}$
Each Converter Shutdown Current		$V_{EN1/EN2} = 0V$ , $V_{IN1/IN2} = 6V$		0.10	1	$\mu\text{A}$
IN Under Voltage Lockout Threshold		Rising Edge	2.15	2.30	2.40	V
IN Under Voltage Lockout Hysteresis				55		mV
Regulated FB Voltage	$V_{FB}$	$T_A = +25^\circ\text{C}$	0.588	0.600	0.612	V
		$-40^\circ\text{C} \leq T_A \leq +85^\circ\text{C}$	0.582	0.600	0.618	
FB Input Bias Current	$I_{FB}$	$V_{FB1/FB2} = 0.65V$	-50	0.5	+50	nA
PFET On Resistance		$I_{SW1/SW2} = 100\text{mA}$		0.42		$\Omega$
NFET On Resistance		$I_{SW1/SW2} = -100\text{mA}$		0.26		$\Omega$
SW Leakage Current		$V_{EN1/EN2} = 0V$ , $V_{IN1/IN2} = 6V$ $V_{SW1/SW2} = 0V$ or $6V$	-2		+2	$\mu\text{A}$
PFET Current Limit		Duty Cycle = 100%, Current Pulse Width < 1ms	0.9	1.3	1.8	A
Oscillator Frequency	$f_{OSC}$		0.99	1.24	1.49	MHz
Thermal Shutdown Trip Threshold				150		$^\circ\text{C}$
EN Enable Threshold		$-40^\circ\text{C} \leq T_A \leq +85^\circ\text{C}$	0.3	0.96	1.5	V
EN Input Current		$V_{EN1/EN2} = 0V$ to $6V$	-1		+1	$\mu\text{A}$

### Notes:

- 5) Production test at +25°C. Specifications over the temperature range are guaranteed by design and characterization.

## TYPICAL PERFORMANCE CHARACTERISTICS

$V_{IN1/IN2} = 3.3V$ ,  $V_{OUT1} = 1.8V$ ,  $V_{OUT2} = 1.2V$ ,  $L_{1/2} = 4.7\mu H$ ,  $C_{IN1/IN2} = 4.7\mu F$ ,  $C_{OUT1/OUT2} = 10\mu F$ ,  $T_A = +25^\circ C$ , unless otherwise noted.

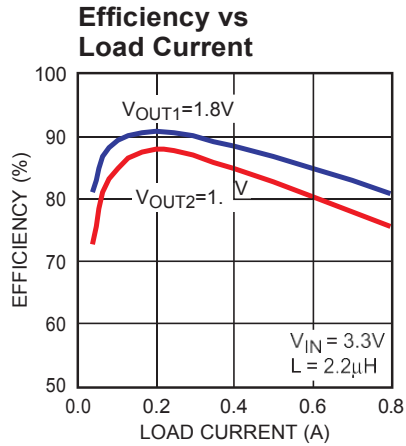

MP2109-TPC01

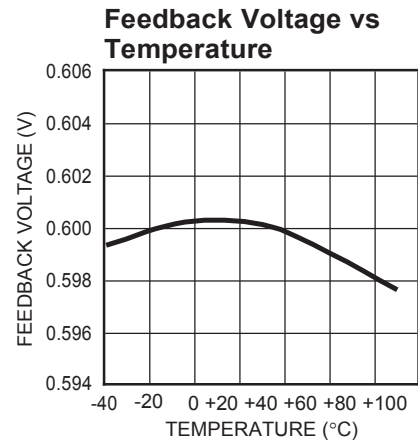

MP2109-TPC02

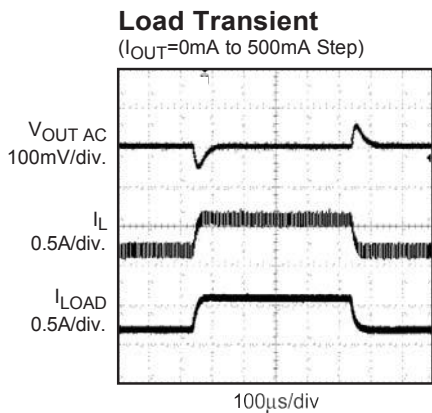

MP2109-TPC03

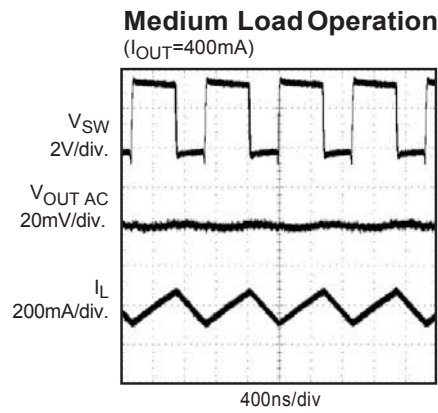

MP2109-TPC04

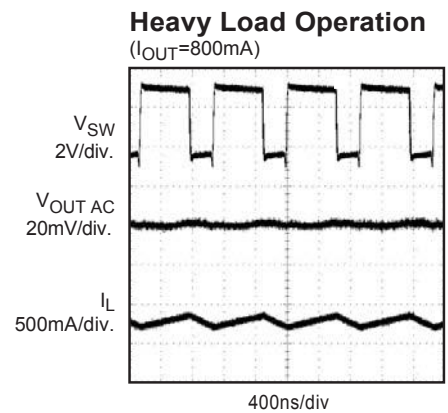

MP2109-TPC05

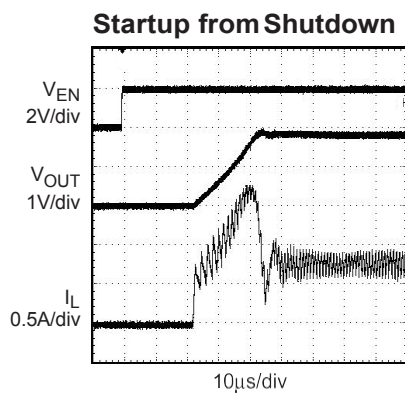

MP2109-TPC06

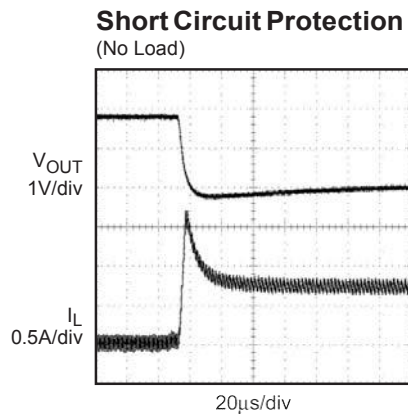

MP2109-TPC07

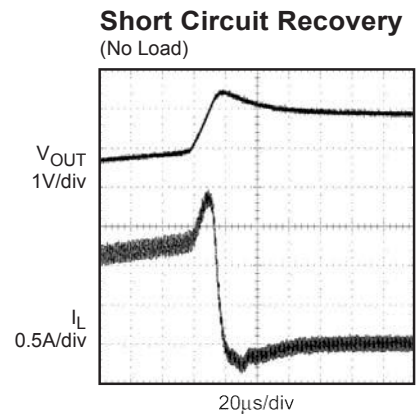

MP2109-TPC08

## PIN FUNCTIONS

Pin #	Name	Description
1	EN1	Channel 1 Enable Control Input. Drive EN1 above 1.5V to turn on the Channel 1. Drive EN1 below 0.3V to turn it off (shutdown current < 0.1 $\mu$ A).
2	FB1	Channel 1 Feedback Input. Connect FB1 to the center point of the external resistor divider. The feedback voltage is 0.6V.
3	IN2	Channel 2 Supply Input. Bypass to GND with a 2.2 $\mu$ F or greater ceramic capacitor.
4	GND2	Ground 2.
5	SW2	Channel 2 Power Switch Output. Inductor connection to drains of the internal PFET and NFET switches.
6	EN2	Channel 2 Enable Control Input. Drive EN2 above 1.5V to turn on the Channel 2. Drive EN2 below 0.3V to turn it off (shutdown current < 0.1 $\mu$ A).
7	FB2	Channel 2 Feedback Input. Connect FB2 to the center point of the external resistor divider. The feedback voltage is 0.6V.
8	IN1	Channel 1 Supply Input. Bypass to GND with a 2.2 $\mu$ F or greater ceramic capacitor.
9	GND1	Ground 1.
10	SW1	Channel 1 Power Switch Output. Inductor connection to drains of the internal PFET and NFET switches.

## OPERATION

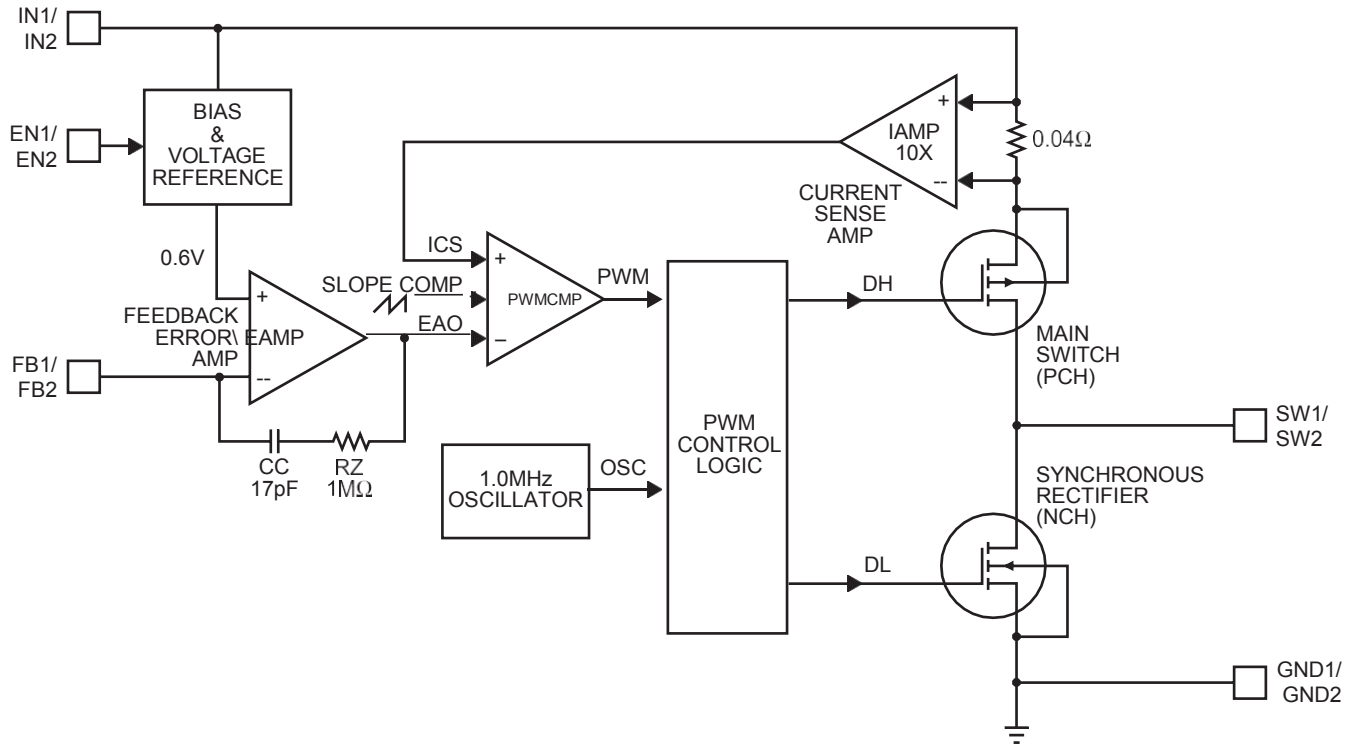

MP2109\_BD02

**Figure 1—Functional Block Diagram (Diagram represents ½ of the MP2109)**

The MP2109 has dual independent constant frequency current mode PWM step-down converters. The MP2109 is optimized for low voltage, Li-Ion battery powered applications where high efficiency and small size are critical. The MP2109 uses external resistor dividers to set two output voltages independently from 0.6V to 6V. The device integrates both main switches and synchronous rectifiers, which provides high efficiency and eliminates the need for an external Schottky diode. The MP2109 can achieve 100% duty cycle. The duty cycle  $D$  of each step-down converter is defined as:

$$D = T_{ON} \times f_{OSC} \times 100\% = \frac{V_{OUT}}{V_{IN}} \times 100\%$$

Where  $T_{ON}$  is the main switch on time,  $f_{OSC}$  is the oscillator frequency (1.2MHz),  $V_{OUT}$  is the output voltage and  $V_{IN}$  is the input voltage.

### Current Mode PWM Control

Slope compensated current mode PWM control provides stable switching and cycle-by-cycle current limit for superior load and line response and protection of the internal main switch and synchronous rectifier. Each channel switches at a constant frequency (1.2MHz) and regulates the output voltage. During each cycle the PWM comparator modulates the power transferred to the load by changing the inductor peak current based on the feedback error voltage. During normal operation, the main switch is turned on for a certain time to ramp the inductor current at each rising edge of the internal oscillator, and switched off when the peak inductor current is above the error voltage. When the main switch is off, the synchronous rectifier will be turned on immediately and stay on until the next cycle starts.

### Dropout Operation

Each channel of the MP2109 allows the main switch to remain on for more than one switching cycle and increases the duty cycle while the input voltage is dropping close to the output voltage. When the duty cycle reaches 100%, the main switch is held on continuously to deliver current to the output up to the PFET current limit. The output voltage then is the input voltage minus the voltage drop across the main switch and the inductor.

### Short Circuit Protection

The MP2109 has short circuit protection. When any output is shorted to ground, the oscillator frequency is reduced to prevent the inductor current from increasing beyond the PFET current limit. The PFET current limit is also reduced to lower the short circuit current. The frequency and current limit will return to the normal values once the short circuit condition is removed and the feedback voltage reaches 0.6V.

### Maximum Load Current

The MP2109 can operate down to 2.5V input voltage, however the maximum load current decreases at lower input due to large IR drop on the main switch and synchronous rectifier. The slope compensation signal reduces the peak inductor current as a function of the duty cycle to prevent sub-harmonic oscillations at duty cycles greater than 50%. Conversely the current limit increases as the duty cycle decreases.

## APPLICATION INFORMATION

### Output Voltage Setting

The external resistor divider sets the output voltage. The feedback resistor R1 also sets the feedback loop bandwidth with the internal compensation capacitor (see Figure 1).

Choose R1 around 300kΩ for optimal transient response. R2 is then given by:

$$R2 = \frac{R1}{\frac{V_{OUT}}{0.6V} - 1}$$

**Table 1—Resistor Selection vs. Output Voltage Setting**

V <sub>OUT</sub>	R1	R2
1.2V	300kΩ (1%)	300kΩ (1%)
1.5V	300kΩ (1%)	200kΩ (1%)
1.8V	300kΩ (1%)	150kΩ (1%)
2.5V	300kΩ (1%)	95.3kΩ (1%)

### Inductor Selection

A 1μH to 10μH inductor with DC current rating at least 25% higher than the maximum load current is recommended for most applications. For best efficiency, the inductor DC resistance shall be <200mΩ. See Table 2 for recommended inductors and manufacturers. For most designs, the inductance value can be derived from the following equation:

$$L = \frac{V_{OUT} \times (V_{IN} - V_{OUT})}{V_{IN} \times \Delta I_L \times f_{OSC}}$$

Where Δ<sub>L</sub> is inductor ripple current. Choose inductor ripple current approximately 30% of the maximum load current, 800mA.

The maximum inductor peak current is:

$$I_{L(MAX)} = I_{LOAD} + \frac{\Delta I_L}{2}$$

Under light load conditions below 100mA, larger inductance is recommended for improved efficiency. Table 3 lists inductors recommended for this purpose.

**Table 2—Suggested Surface Mount Inductors**

Manufacturer	Part Number	Inductance (μH)	Max DCR (Ω)	Saturation Current (A)	Dimensions LxWxH (mm <sup>3</sup> )
Coilcraft	LP03310-222ML	2.2	0.15	1.1	3.3 x 3.3 x 1
Toko	1002AS	2.2	0.11	1.14	4.6 x 4.6 x 1.2
Sumida	CDRH3D16	2.2	0.072	1.20	4 x 4 x 1.8

**Table 3—Inductors for Improved Efficiency at 25mA, 50mA, under 100mA Load.**

Manufacturer	Part Number	Inductance (μH)	Max DCR (Ω)	Saturation Current (A)	I <sub>RMS</sub> (A)
Coilcraft	DO1605T-103MX	10	0.3	1.0	0.9
Murata	LQH4C100K04	10	0.2	1.2	0.8
Sumida	CR32-100	10	0.2	1.0	0.7
Sumida	CR54-100	10	0.1	1.2	1.4

### Input Capacitor Selection

The input capacitor reduces the surge current drawn from the input and switching noise from the device. The input capacitor impedance at the switching frequency shall be less than input source impedance to prevent high frequency switching current passing to the input. Ceramic capacitors with X5R or X7R dielectrics are highly recommended because of their low ESR and small temperature coefficients. For most applications, a 4.7μF capacitor is sufficient.

### Output Capacitor Selection

The output capacitor keeps output voltage ripple small and ensures regulation loop stable. The output capacitor impedance shall be low at the switching frequency. Ceramic capacitors with X5R or X7R dielectrics are recommended. The output ripple ΔV<sub>OUT</sub> is approximately:

$$\Delta V_{OUT} \approx \frac{V_{OUT} \times (V_{IN} - V_{OUT})}{V_{IN} \times f_{OSC} \times L} \left( \frac{L_{SW1}}{8 \times f_{OSC} \times C3} \right)$$

### Thermal Dissipation

Power dissipation shall be considered when both channels of the MP2109 provide maximum 800mA output current to the loads at high ambient temperature with low input supply voltage. If the junction temperature rises above 150°C, the MP2109 two channels will be shut down.

The junction-to-ambient thermal resistance of the 10-pin QFN (3mm x 3mm) R<sub>ΘJA</sub> is 50°C/W. The maximum power dissipation is about 1.6W when the MP2109 is operating in a 70°C ambient temperature environment.

$$P_{D(MAX)} = \frac{150^{\circ}C - 70^{\circ}C}{50^{\circ}C/W} = 1.6W$$

### PC Board Layout

The high current paths (GND1/GND2, IN1/IN2 and SW1/SW2) should be placed very close to

the device with short, direct and wide traces. Input capacitors should be placed as close as possible to the respective IN and GND pins. The external feedback resistors shall be placed next to the FB pins. Keep the switching nodes SW1/SW2 short and away from the feedback network.

## PACKAGE INFORMATION

### QFN10 (3mm x 3mm)

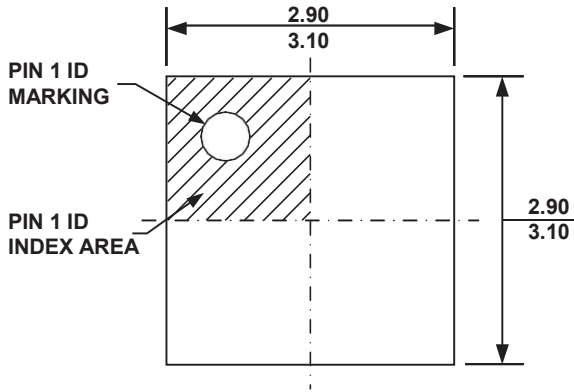

**TOP VIEW**

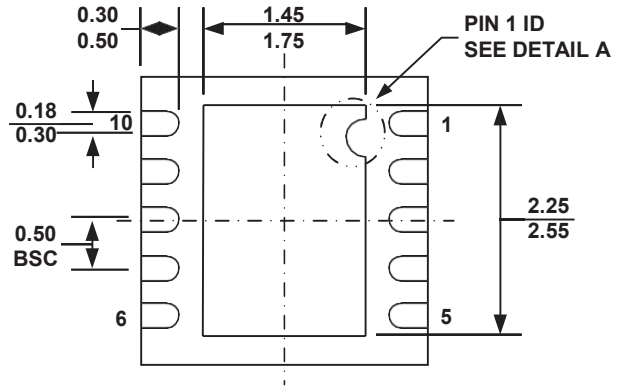

**BOTTOM VIEW**

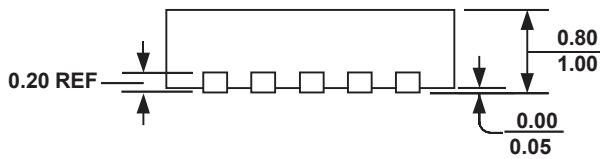

**SIDE VIEW**

**PIN 1 ID OPTION A**  
R0.20 TYP.



**PIN 1 ID OPTION B**  
R0.20 TYP.

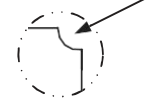

**DETAIL A**

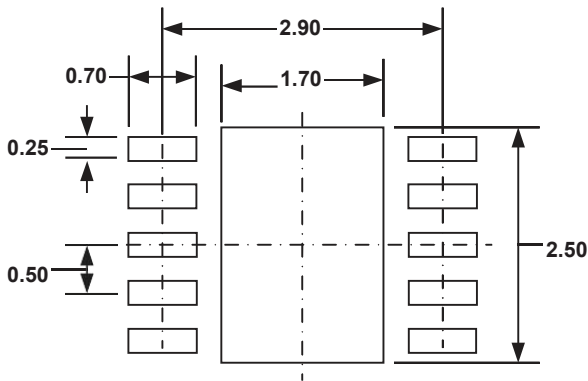

**RECOMMENDED LAND PATTERN**

**NOTE:**

- 1) ALL DIMENSIONS ARE IN MILLIMETERS.
- 2) EXPOSED PADDLE SIZE DOES NOT INCLUDE MOLD FLASH.
- 3) LEAD COPLANARITY SHALL BE 0.10 MILLIMETER MAX.
- 4) DRAWING CONFORMS TO JEDEC MO-229, VARIATION VEED-5.
- 5) DRAWING IS NOT TO SCALE.

**NOTICE:** The information in this document is subject to change without notice. Users should warrant and guarantee that third party Intellectual Property rights are not infringed upon when integrating MPS products into any application. MPS will not assume any legal responsibility for any said applications.