

## Features

- Wide 4.5V to 40V Input Voltage Range
- Output Adjustable from 1.235V to 37V
- Minimum Drop Out 1.5V
- Fixed 150kHz Switching Frequency
- 2A Constant Output Current Capability
- Internal Optimize Power Transistor
- Excellent line and load regulation
- TTL shutdown capability
- ON/OFF pin with hysteresis function
- **With output constant current loop**
- Built in thermal shutdown function
- Built in current limit function
- **Built in output over voltage protection**
- SOP8-EP (Exposed PAD) package

## General Description

The XL4001 is a 150KHz fixed frequency PWM buck (step-down) DC/DC converter, capable of driving a 2A load with high efficiency, low ripple and excellent line and load regulation. Requiring a minimum number of external components, the regulator is simple to use and include internal frequency compensation and a fixed-frequency oscillator.

The PWM control circuit is able to adjust the duty ratio linearly from 0 to 100%. An enable function, an over current protection function is built inside. An internal compensation block is built in to minimize external component count.

## Applications

- Car Charger
- Battery Charger
- LED Constant Current Driver



Figure1. Package Type of XL4001

## Pin Configurations

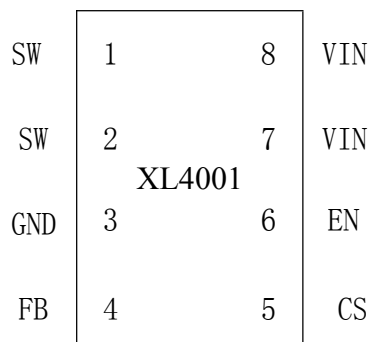

Figure2. Pin Configuration of XL4001 (Top View)

Table 1 Pin Description

Pin Number	Pin Name	Description
1,2	SW	Power Switch Output Pin (SW). Output is the switch node that supplies power to the output.
3	GND	Ground Pin.(Note: <b>Connected the back exposed PAD to Pin3.</b> )
4	FB	Feedback Pin (FB). Through an external resistor divider network, Feedback senses the output voltage and regulates it. The feedback threshold voltage is 1.235V.
5	CS	Output Current Sense Pin; ( $I_{load}=0.155V/R_{cs}$ )
6	EN	Enable Pin. Drive EN pin low to turn on the device, drive it high to turn it off. Floating is default low.
7,8	VIN	Supply Voltage Input Pin. XL4001 operates from a 4.5V to 40V DC voltage. Bypass Vin to GND with a suitably large capacitor to eliminate noise on the input.

Function Block

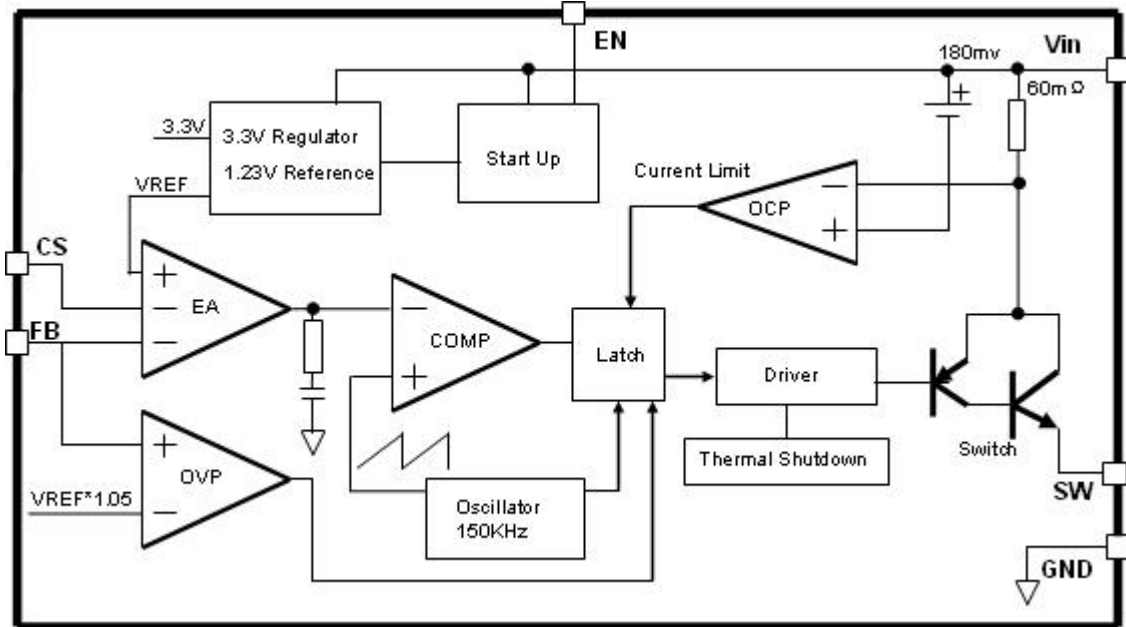

Figure3. Function Block Diagram of XL4001

Typical Application Circuit (Car Charger)

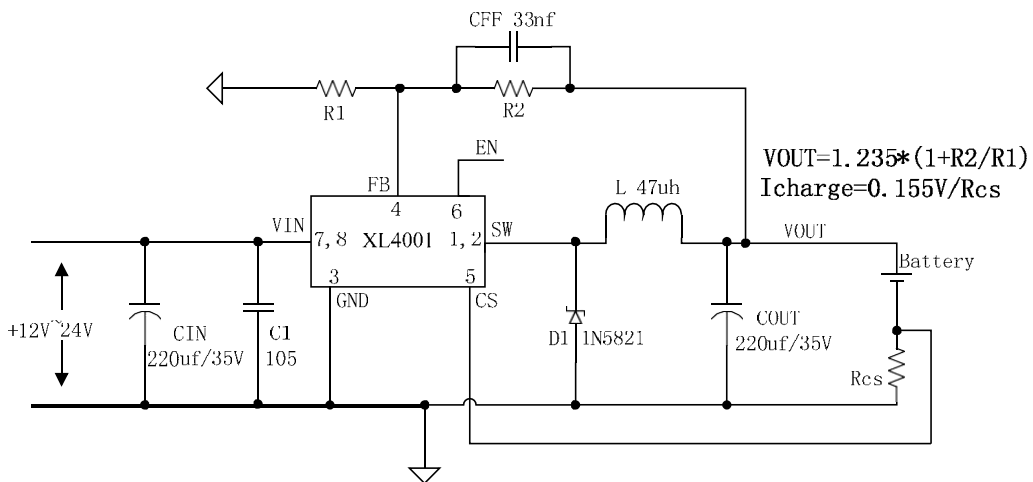

Figure4. XL4001 Typical Application Circuit (Li Battery Charger)

**Typical Application Circuit (Buck LED Constant Current Driver)**

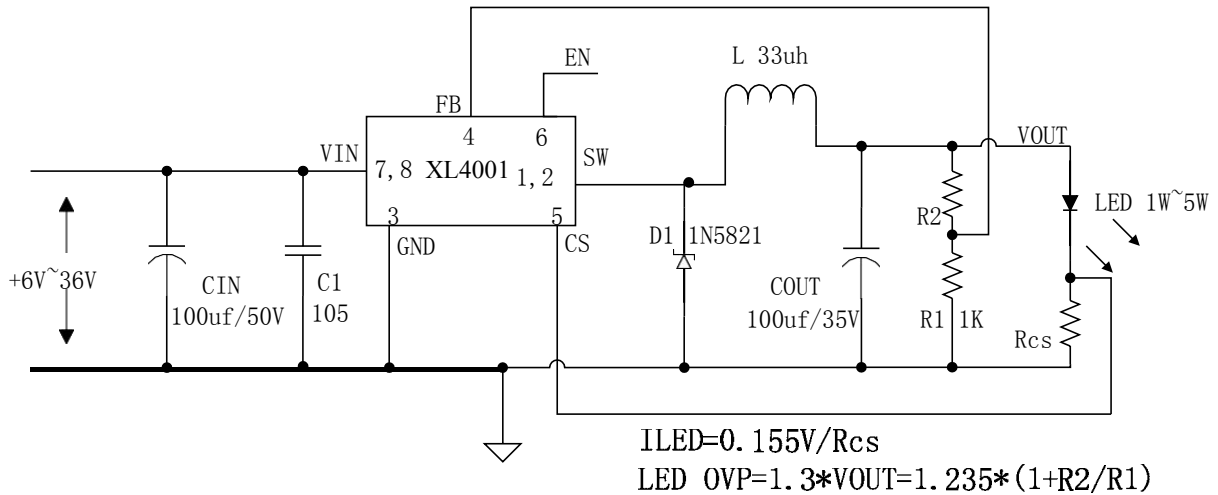

Figure5. XL4001 Typical Application Circuit (LED Constant Current Driver)

**Ordering Information**

Order Information	Marking ID	Package Type	Packing Type Supplied As
XL4001E1	XL4001E1	SOP8-EP	2500 Units on Tape & Reel

XLSEMI Pb-free products, as designated with “E1” suffix in the par number, are RoHS compliant.

**Absolute Maximum Ratings (Note1)**

Parameter	Symbol	Value	Unit
Input Voltage	V <sub>in</sub>	-0.3 to 45	V
FB Pin Voltage	V <sub>FB</sub>	-0.3 to V <sub>in</sub>	V
EN Pin Voltage	V <sub>EN</sub>	-0.3 to V <sub>in</sub>	V
SW Pin Voltage	V <sub>SW</sub>	-0.3 to V <sub>in</sub>	V
Power Dissipation	P <sub>D</sub>	Internally limited	mW
Thermal Resistance (Junction to Ambient, No Heatsink, Free Air)	R <sub>JA</sub>	60	°C/W
Operating Junction Temperature	T <sub>J</sub>	-40 to 125	°C
Storage Temperature	T <sub>STG</sub>	-65 to 150	°C
Lead Temperature (Soldering, 10 sec)	T <sub>LEAD</sub>	260	°C
ESD (HBM)		2000	V

**Note1:** Stresses greater than those listed under Maximum Ratings may cause permanent damage to the device. This is a stress rating only and functional operation of the device at these or any other conditions above those indicated in the operation is not implied. Exposure to absolute maximum rating conditions for extended periods may affect reliability.

**2A 150kHz 40V Buck DC/DC Converter With Constant Current Loop**
**XL4001**
**XL4001 Electrical Characteristics**
 $T_a = 25^\circ\text{C}$ ; unless otherwise specified.

Symbol	Parameter	Test Condition	Min.	Typ.	Max.	Unit
<i>System parameters test circuit figure4</i>						
VFB	Feedback Voltage	$V_{in} = 8\text{V to } 32\text{V}$ , $V_{out}=5\text{V}$ $I_{load}=0.2\text{A to } 2\text{A}$	1.21	1.235	1.26	V
Efficiency	$\eta$	$V_{in}=12\text{V}$ , $V_{out}=5\text{V}$ $I_{out}=2\text{A}$	-	83	-	%

**Electrical Characteristics (DC Parameters)**
 $V_{in} = 12\text{V}$ ,  $GND=0\text{V}$ ,  $V_{in}$  &  $GND$  parallel connect a 220uf/50V capacitor;  $I_{out}=500\text{mA}$ ,  $T_a = 25^\circ\text{C}$ ; the others floating unless otherwise specified.

Parameters	Symbol	Test Condition	Min.	Typ.	Max.	Unit
Input operation voltage	$V_{in}$		4.5		40	V
Shutdown Supply Current	$I_{STBY}$	$V_{EN}=5\text{V}$		80	200	$\mu\text{A}$
Quiescent Supply Current	$I_q$	$V_{EN}=0\text{V}$ , $V_{FB}=V_{in}$		2	5	mA
Oscillator Frequency	$F_{osc}$		127	150	172	Khz
Switch Current Limit	$I_L$	$V_{FB}=0$		3		A
EN Pin Threshold	$V_{EN}$	High (Regulator OFF) Low (Regulator ON)		1.4 0.8		V
Output Saturation Voltage	$V_{CE}$	$V_{FB}=0\text{V}$ $I_{sw}=2\text{A}$		1.1	1.4	V
Constant current sense Voltage	$V_{CS}$		0.140	0.155	0.170	V

### Schottky Diode Selection Table

Current	Surface Mount	Through Hole	VR (The same as system maximum input voltage)				
			20V	30V	40V	50V	60V
1A		√	1N5817	1N5818	1N5819		
3A		√	1N5820	1N5821	1N5822		
		√	MBR320	MBR330	MBR340	MBR350	MBR360
	√		SK32	SK33	SK34	SK35	SK36
	√			30WQ03	30WQ04	30WQ05	
		√		31DQ03	31DQ04	31DQ05	
		√		SR302	SR303	SR304	SR305

Package Information (SOP8-EP)

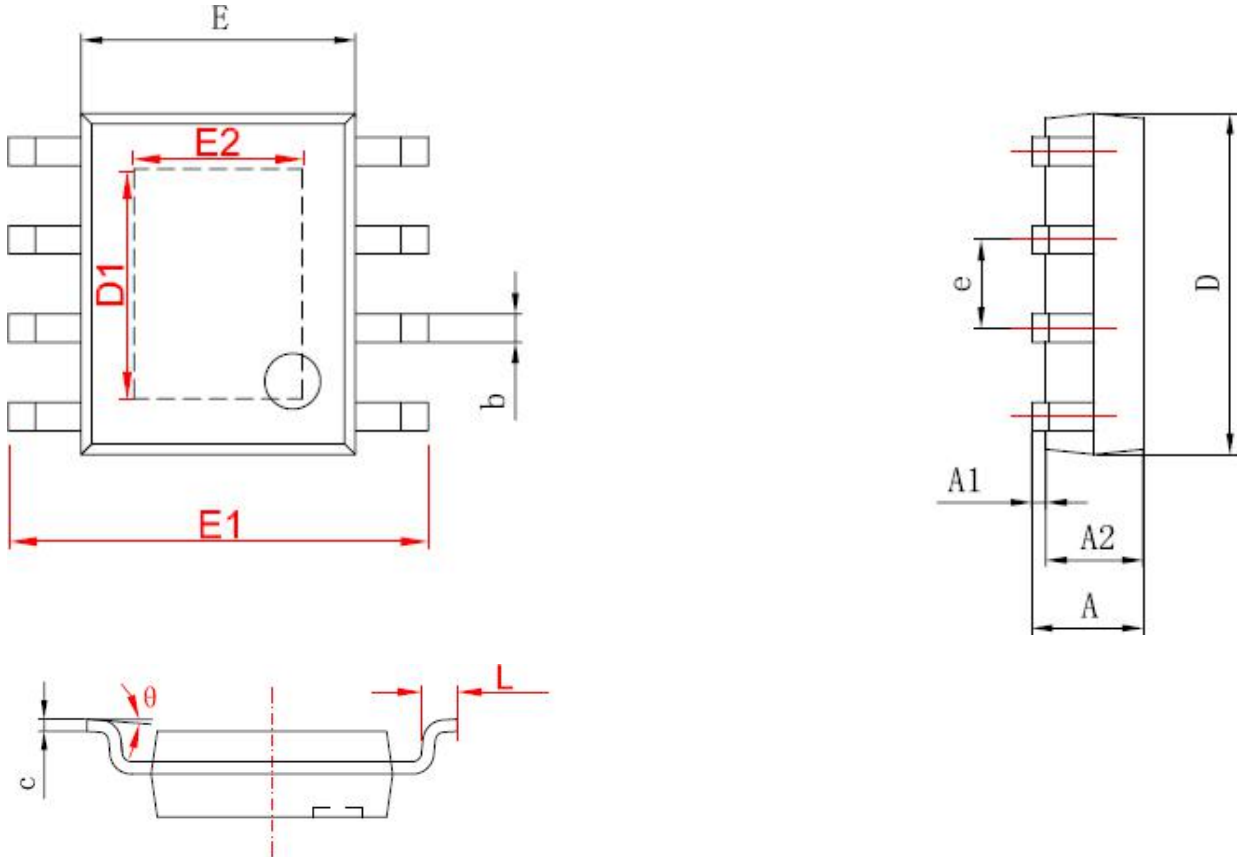

字符	Dimensions In Millimeters		Dimensions In Inches	
	Min	Max	Min	Max
A	1.350	1.750	0.053	0.069
A1	0.050	0.150	0.004	0.010
A2	1.350	1.550	0.053	0.061
b	0.330	0.510	0.013	0.020
c	0.170	0.250	0.006	0.010
D	4.700	5.100	0.185	0.200
D1	3.202	3.402	0.126	0.134
E	3.800	4.000	0.150	0.157
E1	5.800	6.200	0.228	0.244
E2	2.313	2.513	0.091	0.099
e	1.270 (BSC)		0.050 (BSC)	
L	0.400	1.270	0.016	0.050
θ	0°	8°	0°	8°