

Features

- Operation Voltage DC 12V~80V.
- 0.1V current sense voltage reference.
- Directly drive 1~18 Series 1W/3W LED.
- Excellent line and load regulation.
- Internal Optimize Power HV-MOSFET.
- Built in Thermal Shutdown Function.
- Built in Current Limiting Function.
- Built in Soft-Start Circuit.
- Available in TO263-5L package.
- Up to 98% efficiency.

Applications

- LED Lighting & LED LAMP
- General purpose LED lighting

General Description

The XL8002 is a monolithic high voltage switching regulator with PFM that is specifically designed to operate from a 12V~80V DC power supply.

The XL8002 is a high efficiency LED driver switching regulator. The LED string is driven at DC constant current rather than constant voltage, thus providing constant light output and enhanced reliability.



TO263-5L

Figure1. Package Type of XL8002

Pin Configurations

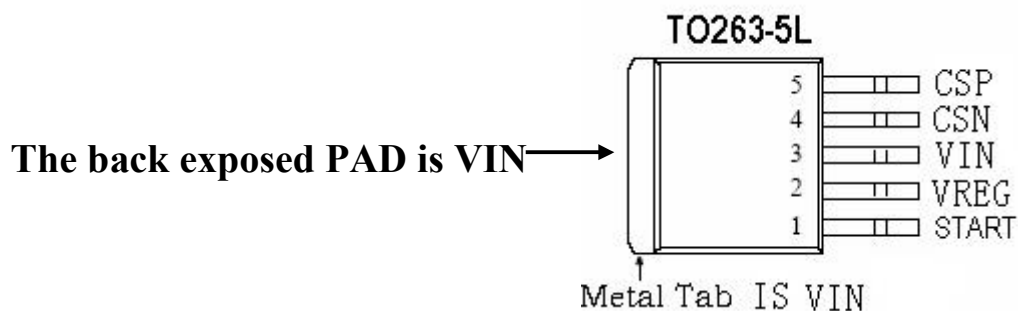

Figure2. Pin Configuration of XL8002 (Top View)

Table 1 Pin Description

Pin Number	Pin Name	Description
1	START	Internal soft start Pin.
2	VREG	Internal Voltage Regulation Pin. (The VREG is about 8V)
3	VIN	Input high voltage Pin. (Operation voltage 12V~80V)
4	CSN	Current Sense Negative Pin.
5	CSP	Current Sense Positive Pin. (The current sense voltage is 0.1V)

XL8002

Function Block

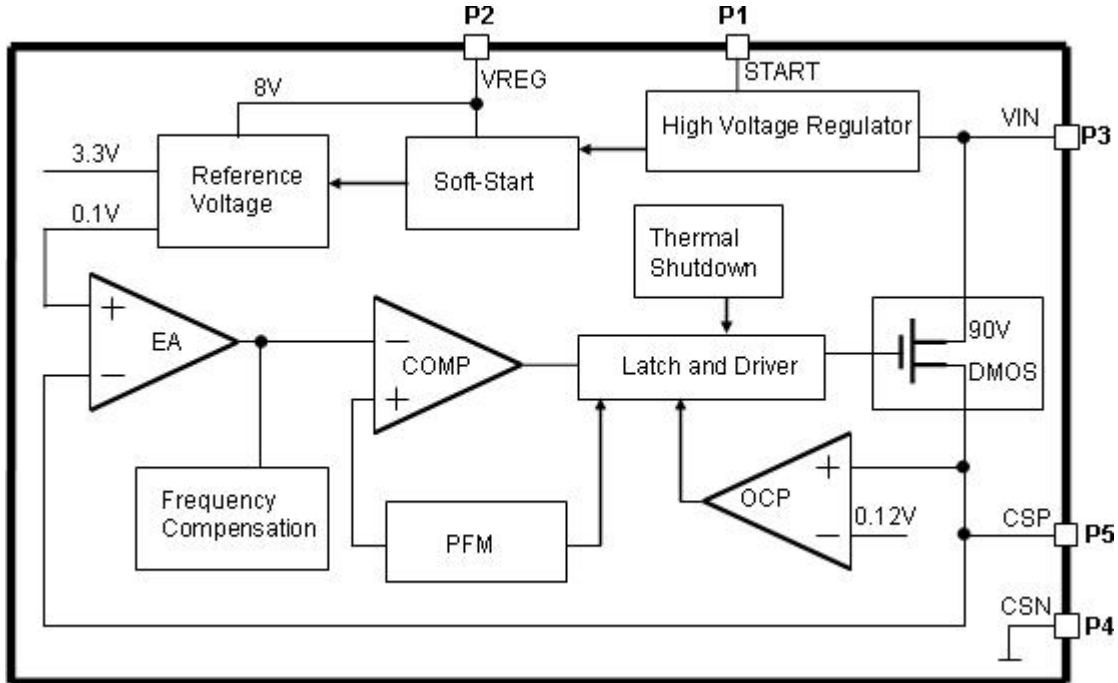

Figure3. Function Block Diagram of XL8002

Typical Application Circuit

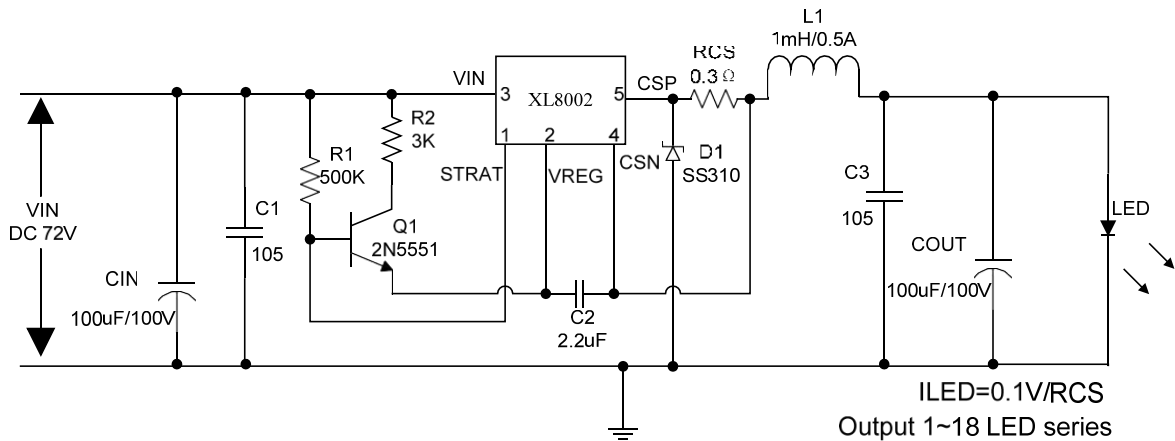

Figure4. XL8002 Typical Application

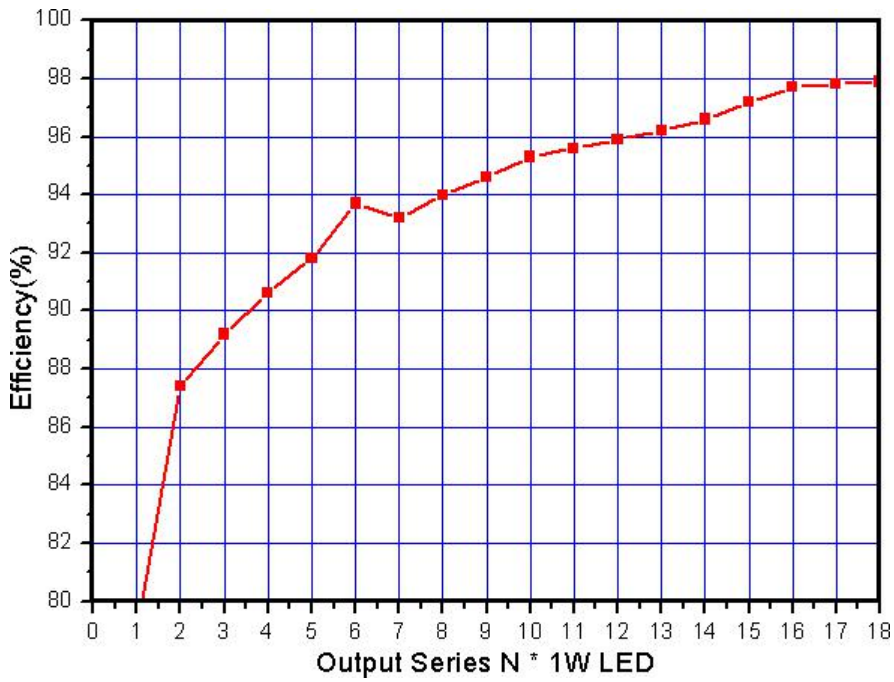

Figure5. Efficiency VS Output N*1W LED



Figure6. Output ILED Load Regulation VS Output N*1W LED

Ordering Information

Order Information	Marking ID	Package Type	Packing Type Supplied As
XL8002E1	XL8002E1	TO263-5L	800 Units on Tape & Reel

XLSEMI Pb-free products, as designated with “E1” suffix in the par number, are RoHS compliant.

Absolute Maximum Ratings (Note1)

Parameter	Symbol	Value	Unit
Input Voltage	V_{in}	-0.3 to 90	V
Power Dissipation	P_D	Internally limited	mW
Thermal Resistance (TO263-5L) (Junction to Ambient, No Heatsink, Free Air)	R_{JA}	30	°C/W
Operating Junction Temperature	T_J	-40 to 125	°C
Storage Temperature	T_{STG}	-65 to 150	°C
Lead Temperature (Soldering, 10 sec)	T_{LEAD}	260	°C
ESD (HBM)		>3000	V

Note1: Stresses greater than those listed under Maximum Ratings may cause permanent damage to the device. This is a stress rating only and functional operation of the device at these or any other conditions above those indicated in the operation is not implied. Exposure to absolute maximum rating conditions for extended periods may affect reliability.

XL8002

XL8002 Electrical Characteristics

T_a = 25°C; unless otherwise specified. Reference test circuit figure4

Symbol	Parameter	Test Condition	Min.	Typ.	Max.	Unit
VCSP	CSP Voltage	VIN=72V; Iled=300mA; Series 1~18 1W LED	96	100	104	mV
Efficiency	η	VIN=72V; Iled=300mA; Pout=16W	-	98	-	%

Electrical Characteristics (DC Parameters)

Parameters	Symbol	Test Condition	Min.	Typ.	Max.	Unit
Input operation voltage	VIN		12		80	V
Switching Frequency	Fosc	Figure4 (12*1W) VIN=72V	102	127	152	KHz
Max. Duty Cycle	D _{MAX}			85		%
VDMOS Drain-Source Breakdown Voltage	V _{BRDS}	V _{GS} =0V, I _{DS} =250uA	90			V
VDMOS Drain-Source on resistor	R _{DSON}	I _{DS} =1A, V _{GS} =8V		100	120	mOhm
Thermal Shutdown	OTP	T _j		160		°C
Thermal Shutdown Window				20		°C

[1] Typical System Application (VIN=60V~80V)

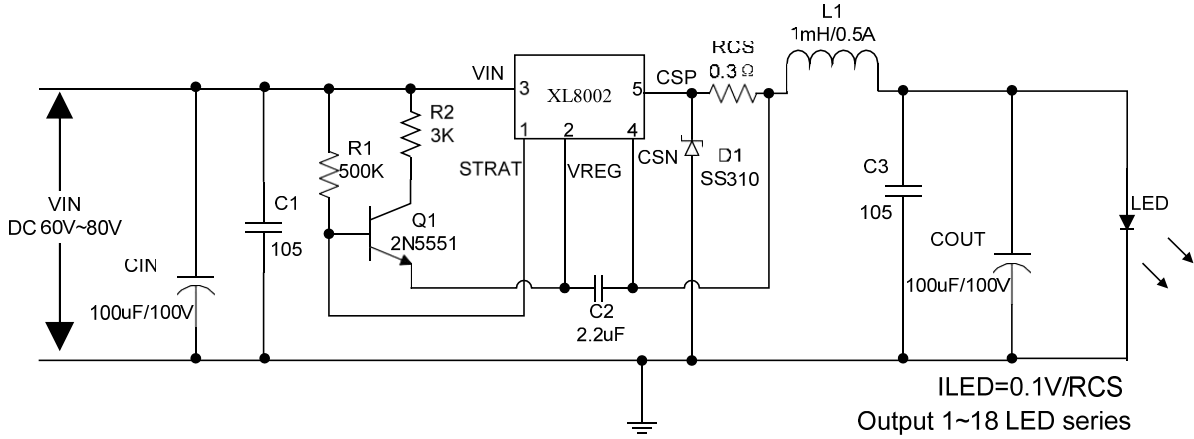

Figure7. XL8002 System Application at VIN=60V~80V Schematic

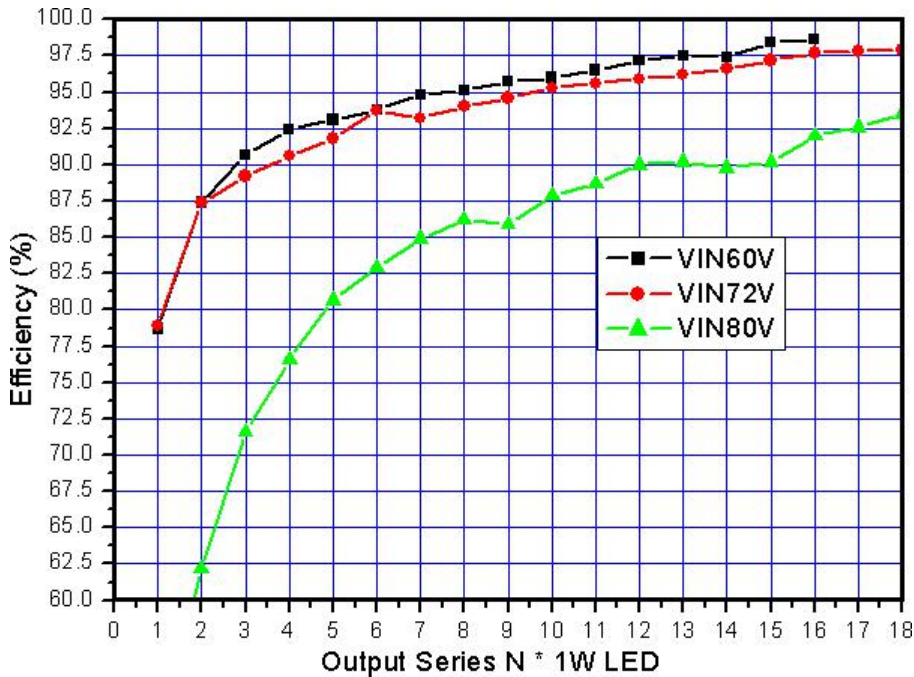

Figure8. XL8002 System Application at VIN=60V~80V Efficiency Curve

XL8002

Table1: Figure7 Input VIN=60V/72V/80V system parameters table:

LED String 1W*N	VIN=60V			VIN=72V			VIN=80V		
	FOSC	Pout	Efficiency	FOSC	Pout	Efficiency	FOSC	Pout	Efficiency
1	27.54K	1.04W	78.7%	25.41K	0.97W	78.9%	28.84K	1.14W	50.8%
2	45.90K	1.99W	87.4%	45.76K	2.02W	87.4%	46.98K	2.09W	62.2%
3	61.79K	2.94W	90.7%	61.10K	2.89W	89.2%	63.69K	3.04W	71.6%
4	74.70K	3.83W	92.4%	75.13K	3.79W	90.6%	78.04K	3.92W	76.6%
5	85.92K	4.75W	93.1%	87.70K	4.70W	91.8%	91.51K	4.85W	80.7%
6	94.64K	5.63W	93.8%	98.50K	5.61W	93.7%	103.35K	5.78W	82.9%
7	101.06K	6.48W	94.8%	107.44K	6.45W	93.2%	113.48K	6.66W	84.9%
8	105.65K	7.36W	95.1%	114.66K	7.37W	94.0%	121.91K	7.52W	86.2%
9	108.26K	8.21W	95.7%	120.15K	8.24W	94.6%	129.09K	8.39W	85.9%
10	109.06K	9.10W	96.0%	124.10K	9.13W	95.3%	134.73K	9.29W	87.9%
11	107.72K	10.01W	96.5%	126.54K	10.12W	95.6%	138.71K	10.16W	88.7%
12	104.57K	10.91W	97.2%	126.90K	10.97W	95.9%	141.32K	11.03W	90.0%
13	98.61K	11.92W	97.5%	125.62K	11.92W	96.2%	142.28K	12.00W	90.2%
14	88.21K	12.92W	97.4%	122.06K	12.94W	96.6%	141.32K	13.02W	89.8%
15	74.63K	13.87W	98.4%	116.52K	13.94W	97.2%	137.62K	13.95W	90.2%
16	46.44K	15.62W	98.6%	99.20K	15.77W	97.7%	121.04K	15.84W	92.0%
17				89.37K	16.69W	97.8%	113.56K	16.37W	92.6%
18				75.17K	17.64W	97.9%	103.65K	17.36W	93.5%

[2] Typical System Application (VIN=36V~60V)

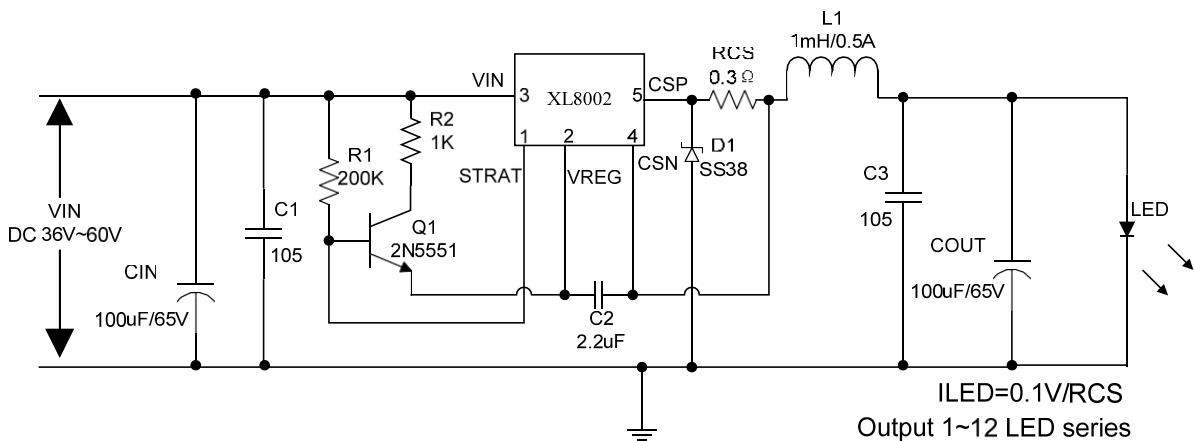

Figure9. XL8002 System Application at VIN=36V~60V Schematic

XL8002

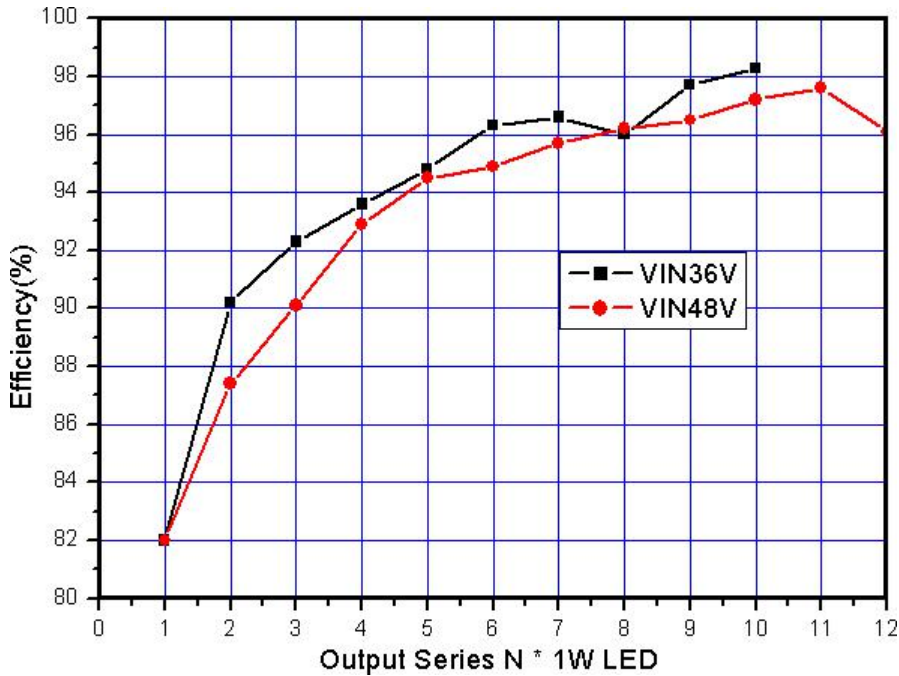

Figure10. XL8002 System Application at VIN=36V~60V Efficiency Curve

Table2: Figure9 Input VIN=36V/48V system parameters table:

LED String 1W*N	VIN=36V			VIN=48V		
	FOSC	Pout	Efficiency	FOSC	Pout	Efficiency
1	28.83K	1.09W	82.0%	29.18K	1.10W	82.0%
2	45.06K	2.05W	90.2%	46.81K	2.06W	87.4%
3	56.98K	2.99W	92.3%	61.45K	2.98W	90.1%
4	64.58K	3.88W	93.6%	72.05K	3.88W	92.9%
5	68.53K	4.77W	94.8%	80.32K	4.76W	94.5%
6	68.66K	5.68W	96.3%	85.95K	5.65W	94.9%
7	65.21K	6.57W	96.6%	88.95K	6.52W	95.7%
8	58.26K	7.36W	96.0%	89.37K	7.38W	96.2%
9	48.75K	8.33W	97.7%	87.31K	8.24W	96.5%
10	34.20K	9.29W	98.3%	82.56K	9.14W	97.2%
11				74.92K	10.06W	97.6%
12				62.77K	10.92W	96.1%

[3] Typical System Application (VIN=12V~36V)

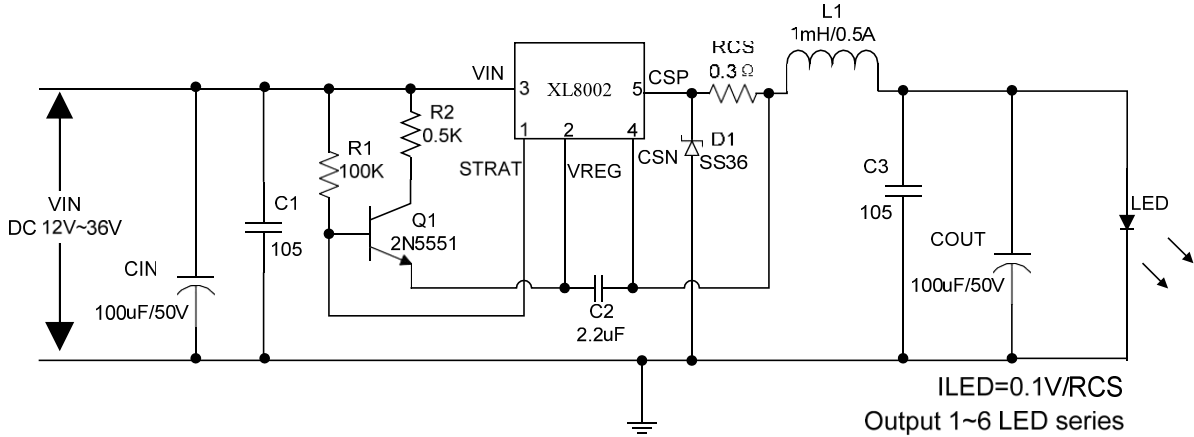

Figure11. XL8002 System Application at VIN=12V~36V Schematic

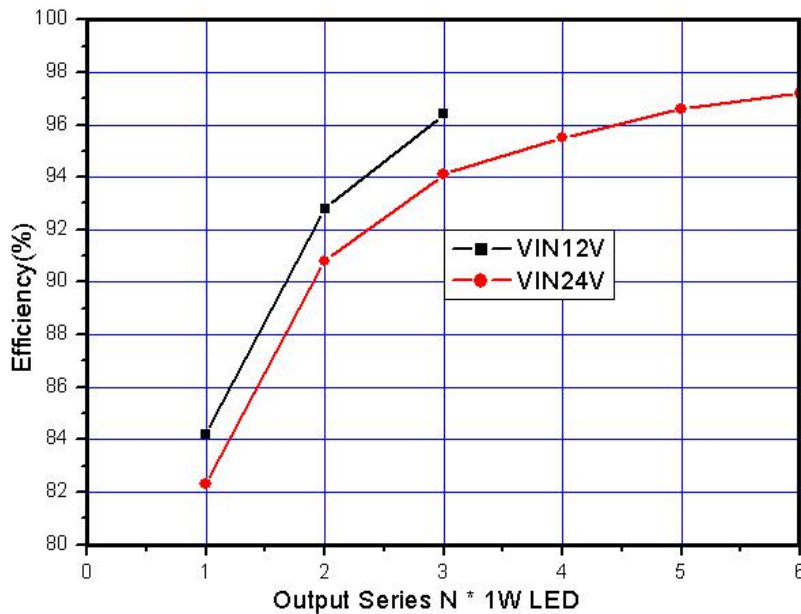

Figure12. XL8002 System Application at VIN=12V~36V Efficiency Curve

Table3: Figure11 Input VIN=12V/24V system parameters table:

LED String 1W*N	VIN=12V			VIN=24V		
	FOSC	Pout	Efficiency	FOSC	Pout	Efficiency
1	22.75K	1.06W	84.2%	26.42K	1.01W	82.3%
2	24.18K	2.02W	92.8%	39.74K	1.96W	90.8%
3	10.37K	3.10W	96.4%	46.63K	2.91W	94.1%
4				47.25K	3.80W	95.5%
5				42.17K	4.70W	96.6%

XL8002

6				31.13K	5.61W	97.2%	
----------	--	--	--	---------------	--------------	--------------	--

[4] Typical System Application (VIN=60V~80V, Output Series 3W LED)

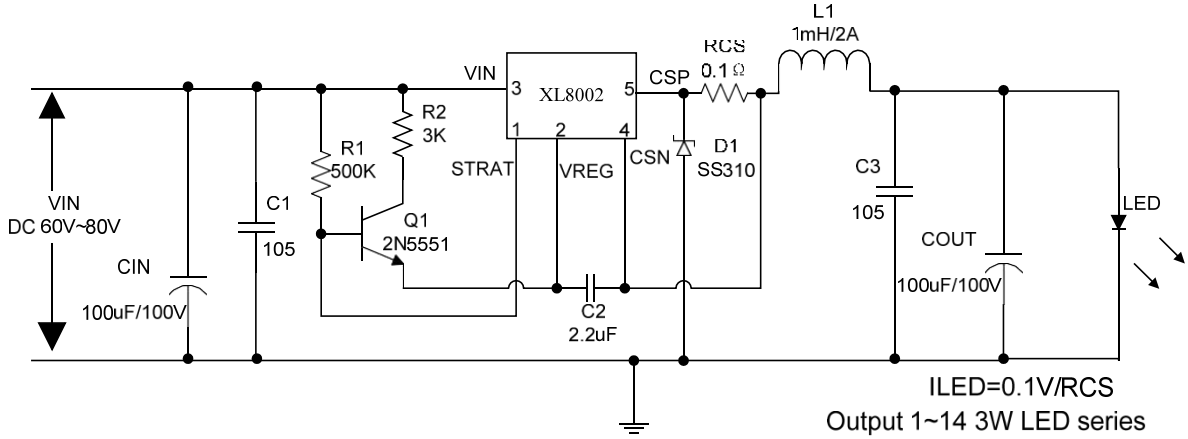

Figure13. XL8002 System Application at VIN=60V~80V Schematic

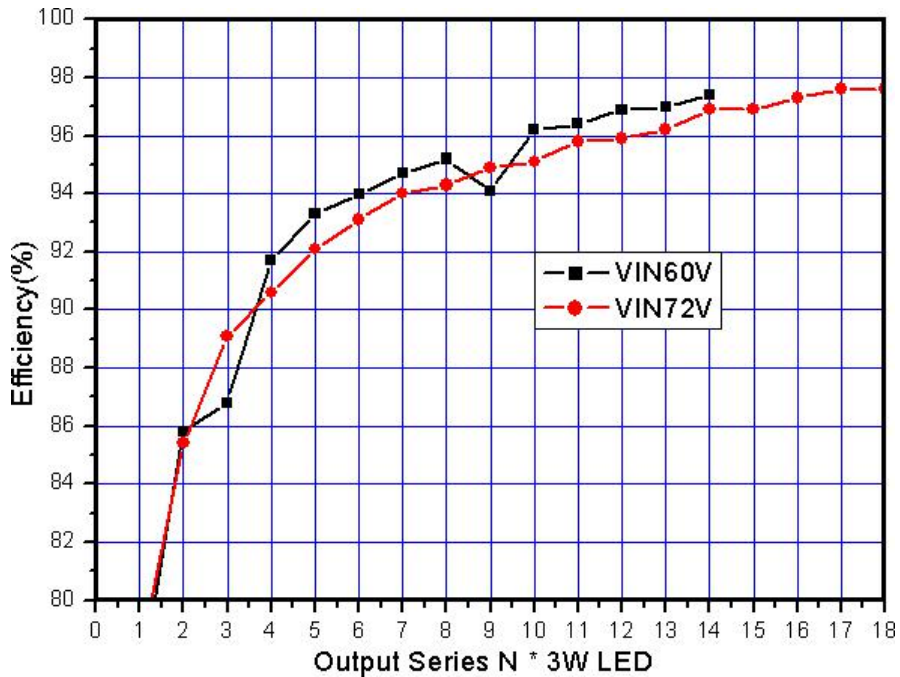

Figure14. XL8002 System Application at VIN=60V~80V Efficiency Curve

XL8002

Table4: Figure13 Input VIN=60V/72V system parameters table:

LED String 3W*N	VIN=60V			VIN=72V		
	FOSC	Pout	Efficiency	FOSC	Pout	Efficiency
1	29.69K	3.09W	76.8%	30.19K	3.31W	77.9%
2	49.15K	6.04W	85.8%	49.44K	6.28W	85.4%
3	67.05K	8.92W	86.8%	66.47K	9.19W	89.1%
4	79.40K	11.68W	91.7%	80.02K	11.76W	90.6%
5	90.69K	14.40W	93.3%	92.67K	14.47W	92.1%
6	99.29K	16.99W	94.0%	103.38K	17.11W	93.1%
7	105.99K	19.68W	94.7%	112.28K	19.72W	94.0%
8	110.14K	22.24W	95.2%	119.03K	22.30W	94.3%
9	112.33K	24.62W	94.1%	124.22K	24.90W	94.9%
10	112.21K	27.43W	96.2%	127.71K	27.42W	95.1%
11	110.21K	29.95W	96.4%	129.30K	30.02W	95.8%
12	106.33K	32.32W	96.9%	129.88K	32.44W	95.9%
13	100.82K	34.72W	97.0%	125.21K	35.28W	96.2%
14	92.68K	37.37W	97.4%	122.24K	37.92W	96.9%
15				119.06K	40.50W	96.9%
16				112.73K	42.86W	97.3%
17				103.35K	45.47W	97.6%
18				93.18K	47.89W	97.6%

Schottky Diode Selection Table

VR	1A	3A				
20V	1N5817	SS32	SK32	1N5820	MBR320	SR302
30V	1N5818	SS33	SK33	1N5821	MBR330	SR303
40V	1N5819	SS34	SK34	1N5822	MBR340	SR304
50V		SS35	SK35		MBR350	SR305
60V		SS36	SK36		MBR360	SR306
70V		SS37	SK37			SR307
80V		SS38	SK38			SR308
90V		SS39	SK39			SR309
100V		SS310	S310			SR310

Package Information

TO263-5L

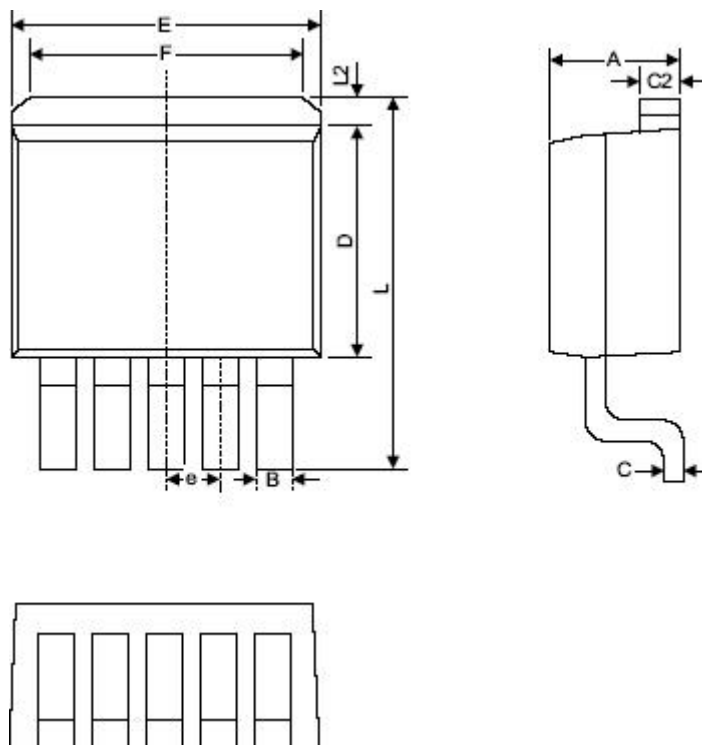

Symbol	Dimensions In Millimeters		Dimensions In Inches	
	Min.	Max.	Min.	Max.
A	4.06	4.83	0.160	0.190
B	0.71	1.02	0.028	0.040
C	0.36	0.76	0.014	0.030
C2	1.14	1.40	0.045	0.055
D	8.38	8.89	0.330	0.350
E	9.78	10.54	0.385	0.415
e	1.57	1.85	0.062	0.073
F	6.60	7.11	0.260	0.280
L	-	15.35	-	0.604
L2	-	1.40	-	0.055