

Features

- Wide 3.6V to 32V Input Voltage Range
- 0.22V FB adjustable LED drive current
- Directly drive 11 Series 1W LED at $V_{IN} \geq 12V$
- Fixed 180KHz Switching Frequency
- Max. 4A Switching Current Capability
- Up to 94% efficiency
- Excellent line and load regulation
- EN PIN TTL shutdown capability & With PWM Dimming Function
- Internal Optimize Power MOSFET
- Built in Soft-Start Function
- Built in Frequency Compensation
- Built in Thermal Shutdown Function
- Built in Current Limit Function
- Available in TO252-5L package

Applications

- LED Lighting
- Boost constant current driver
- Monitor LED Backlighting
- 7' to 15' LCD Panels

General Description

The XL6005 regulator is fixed frequency PWM Boost (step-up) LED constant current driver, capable of driving Series 1W/3W/5W LED units with excellent line and load regulation. The regulator is simple to use because it includes internal frequency compensation and a fixed-frequency oscillator so that it requires a minimum number of external components to work.

The XL6005 could directly drive 11 Series 1W LED units at $V_{IN} \geq 12V$.

The PWM control circuit is able to adjust the duty ratio linearly from 0 to 90%. An enable function, an over current protection function is built inside. An internal compensation block is built in to minimize external component count.

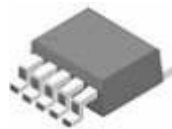

Figure1. Package Type of XL6005

Pin Configurations

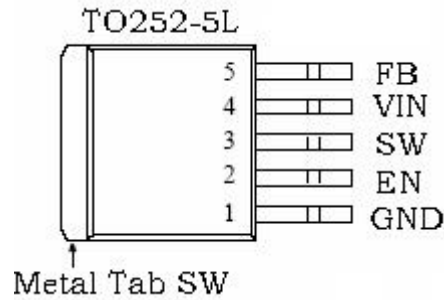

Figure2. Pin Configuration of XL6005 (Top View)

Table 1 Pin Description

Pin Number	Pin Name	Description
1	GND	Ground Pin.
2	EN	Enable Pin. Drive EN pin low to turn off the device, drive it high to turn it on. Floating is default high.
3	SW	Power Switch Output Pin (SW).
4	VIN	Supply Voltage Input Pin. XL6005 operates from a 3.6V to 32V DC voltage. Bypass Vin to GND with a suitably large capacitor to eliminate noise on the input.
5	FB	Feedback Pin (FB). The feedback threshold voltage is 0.22V.

Function Block

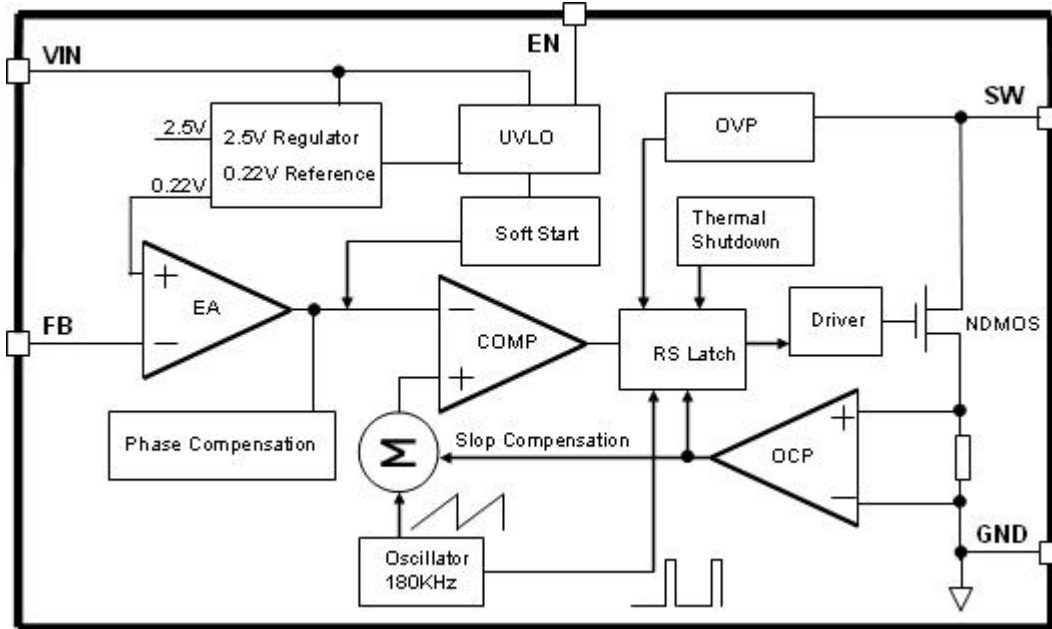

Figure3. Function Block Diagram of XL6005

Typical Application Circuit

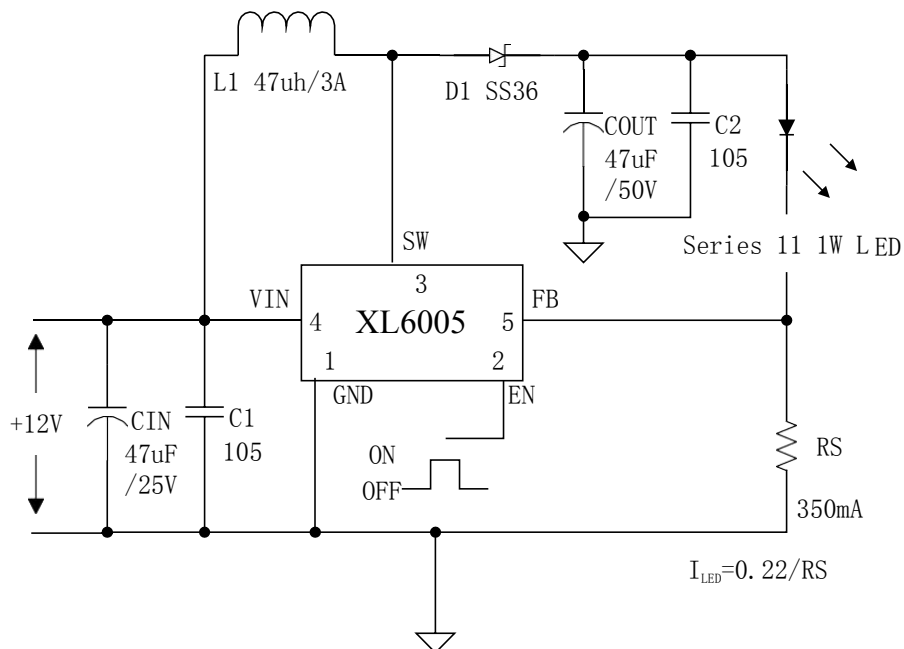

Figure4. XL6005 Typical Application Circuit

180KHz 60V 4A Switching Current Boost LED Constant Current Driver

XL6005

Ordering Information

Order Information	Marking ID	Package Type	Packing Type Supplied As
XL6005E1	XL6005E1	TO252-5L	2500 Units on Tape & Reel

XLSEMI Pb-free products, as designated with “E1” suffix in the par number, are RoHS compliant.

Absolute Maximum Ratings (Note1)

Parameter	Symbol	Value	Unit
Input Voltage	V_{in}	-0.3 to 36	V
Feedback Pin Voltage	V_{FB}	-0.3 to V_{in}	V
EN Pin Voltage	V_{EN}	-0.3 to V_{in}	V
Output Switch Pin Voltage	V_{Output}	-0.3 to 60	V
Power Dissipation	P_D	Internally limited	mW
Thermal Resistance (TO252-5L) (Junction to Ambient, No Heatsink, Free Air)	R_{JA}	50	°C/W
Operating Junction Temperature	T_J	-40 to 125	°C
Storage Temperature	T_{STG}	-65 to 150	°C
Lead Temperature (Soldering, 10 sec)	T_{LEAD}	260	°C
ESD (HBM)		>2000	V

Note1: Stresses greater than those listed under Maximum Ratings may cause permanent damage to the device. This is a stress rating only and functional operation of the device at these or any other conditions above those indicated in the operation is not implied. Exposure to absolute maximum rating conditions for extended periods may affect reliability.

180KHz 60V 4A Switching Current Boost LED Constant Current Driver

XL6005

XL6005 Electrical Characteristics

$T_a = 25^\circ\text{C}$; unless otherwise specified.

Symbol	Parameter	Test Condition	Min.	Typ.	Max.	Unit
<i>System parameters test circuit figure4</i>						
VFB	Feedback Voltage	$V_{in} = 5\text{V to } 12\text{V}, V_{out}=24\text{V}$ $I_{load}=100\text{mA}$	209	220	231	mV
Efficiency	η	$V_{in}=12\text{V}, V_{out}=24\text{V}$ $I_{out}=1\text{A}$	-	92	-	%

Electrical Characteristics (DC Parameters)

$V_{in} = 12\text{V}$, $GND=0\text{V}$, V_{in} & GND parallel connect a 100uf/50V capacitor; $I_{out}=100\text{mA}$, $T_a = 25^\circ\text{C}$; the others floating unless otherwise specified.

Parameters	Symbol	Test Condition	Min.	Typ.	Max.	Unit
Input operation voltage	V_{in}		3.6		32	V
Shutdown Supply Current	I_{STBY}	$V_{EN}=0\text{V}$		70	100	μA
Quiescent Supply Current	I_q	$V_{EN}=2\text{V}$, $V_{FB}=V_{in}$		2.5	5	mA
Oscillator Frequency	F_{osc}		144	180	216	KHz
Switch Current Limit	I_L	$V_{FB}=0$		4		A
Output Power NMOS	R_{dson}	$V_{in}=12\text{V}$, $I_{sw}=4\text{A}$		110	120	mohm
EN Pin Threshold	V_{EN}	High (Regulator ON) Low (Regulator OFF)		1.4 0.8		V
EN Pin Input Leakage Current	I_H	$V_{EN}=2\text{V}$ (ON)		3	10	μA
	I_L	$V_{EN}=0\text{V}$ (OFF)		3	10	μA
Max. Duty Cycle	D_{MAX}	$V_{FB}=0\text{V}$		90		%

180KHz 60V 4A Switching Current Boost LED Constant Current Driver

XL6005

Typical System Application for VIN=12V to driver 11 x 1W series LED units

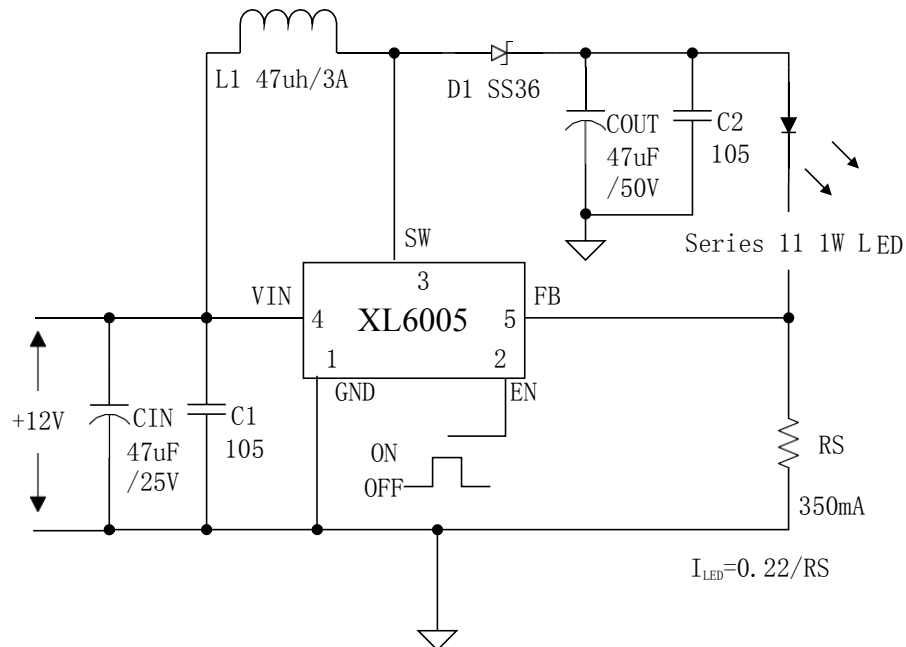

Figure5. XL6005 System Parameters Test Circuit (12V ~ 11 x 1W LED)

Typical System Application for VIN ≥ 12V to driver 6 x 3W series LED units

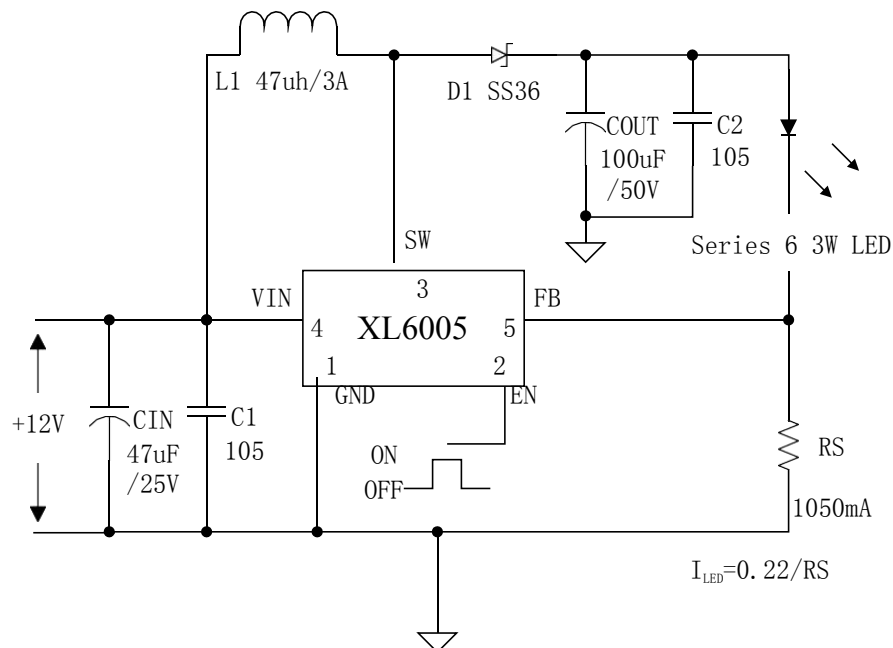

Figure6. XL6005 System Parameters Test Circuit (12V ~ 6 x 3W LED)

Typical System Application for $V_{IN} \geq 24V$ to driver 10 x 3W series LED units

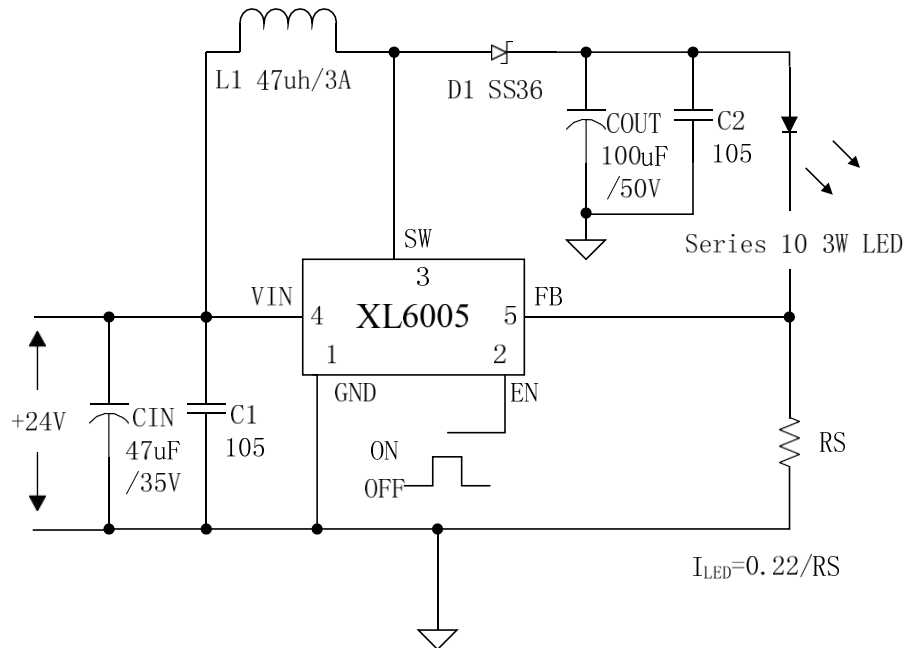

Figure7. XL6005 System Parameters Test Circuit (24V ~ 10 x 3W LED)

Typical System Application for $V_{IN} \geq 12V$ to driver 11 series x 40 parallel White LED Array

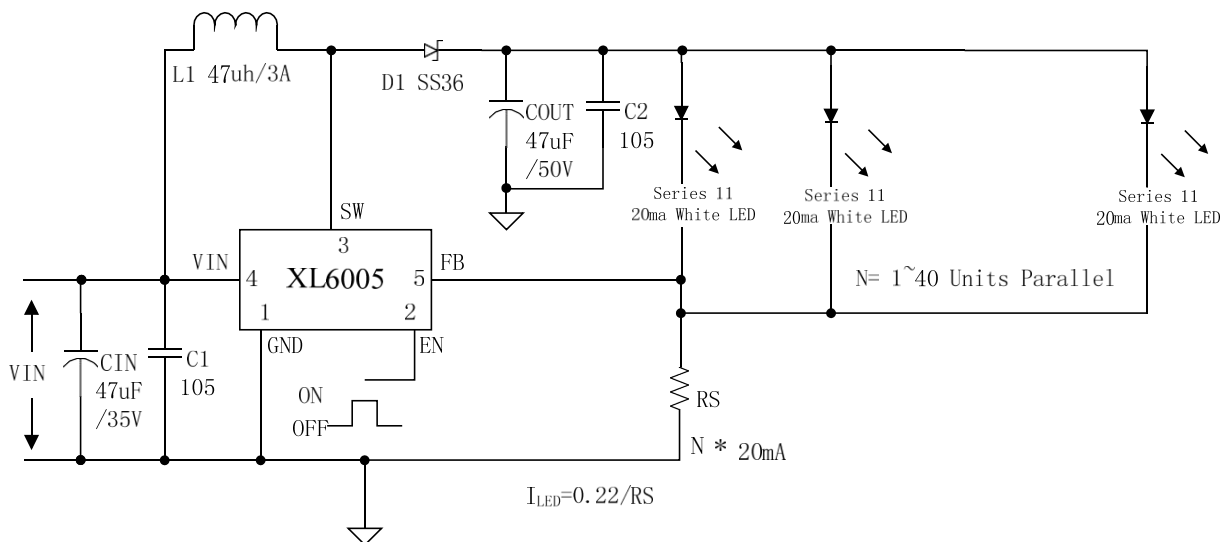

Figure8. XL6005 System Parameters Test Circuit ($V_{IN} \geq 12V$ ~ 11 x 40 White LED)

Typical System Application for SEPIC Buck-Boost LED Driver

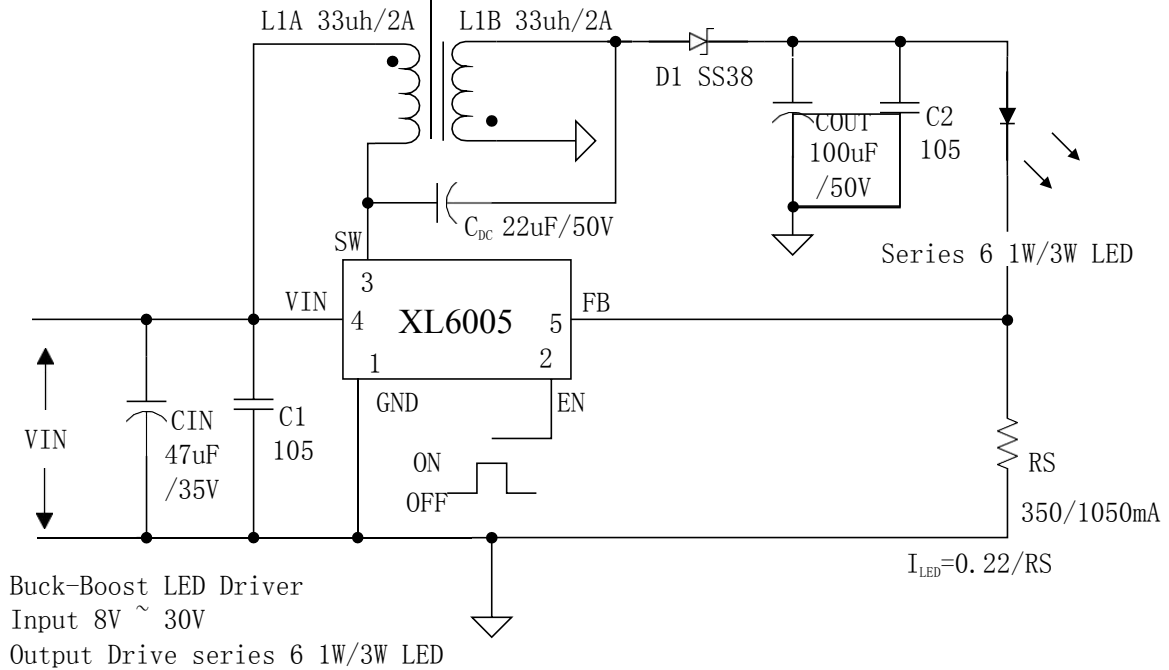

Figure9. XL6005 System Parameters Test Circuit (Buck-Boost LED Driver)

Typical System Application for VIN >= 12V to driver 8 x 2W series LED units With Dimming Function

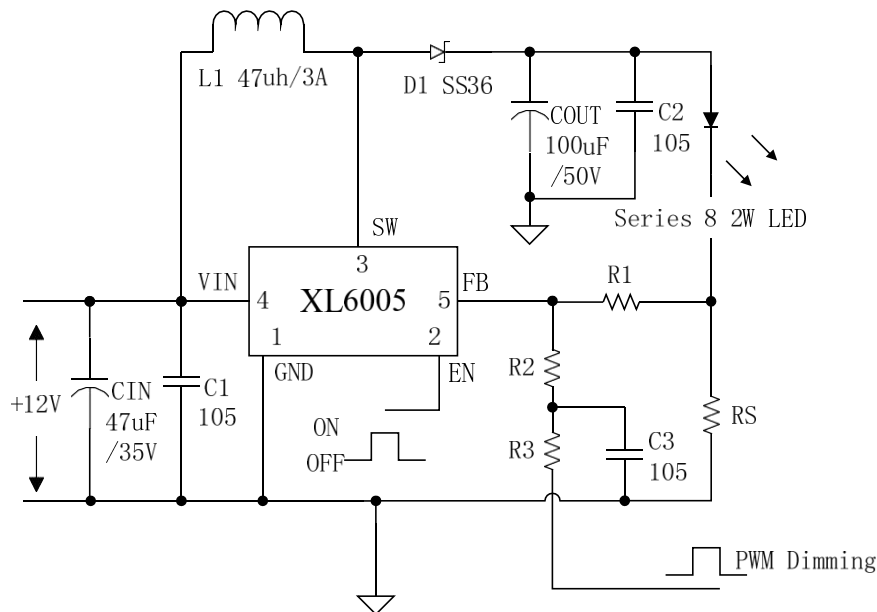

Figure10. XL6005 System Test Circuit (12V ~ 8 x 2W LED with Dimming Function)

Typical System Application (LED OVP)

LED OVP function can be used in typical system application with external components. The output voltage can be limited in a suitable value by choose different zener diode when the output LED open. the zener diode voltage choosed by output led voltage's 1.3 times.

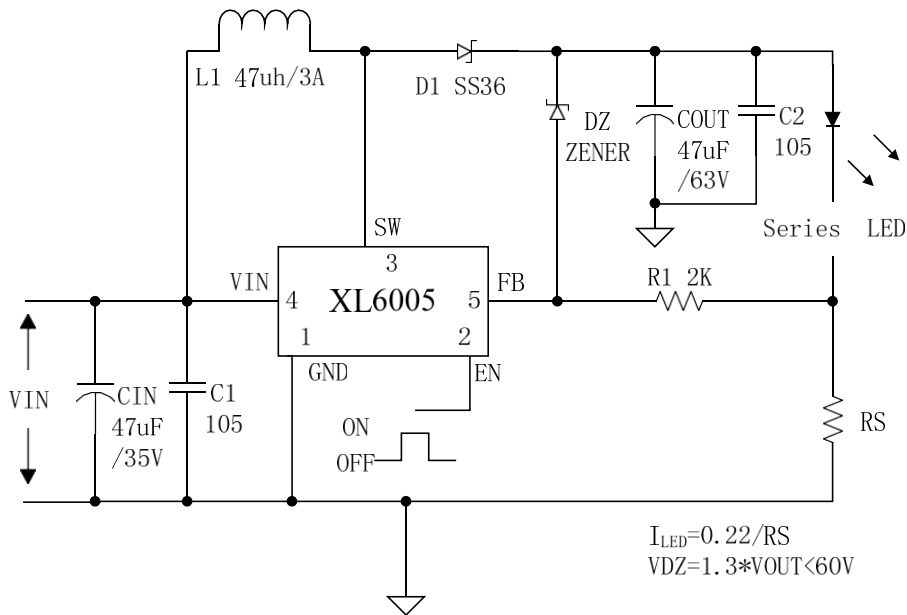
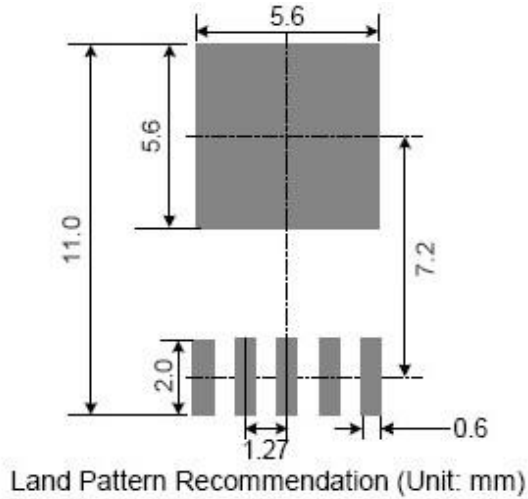
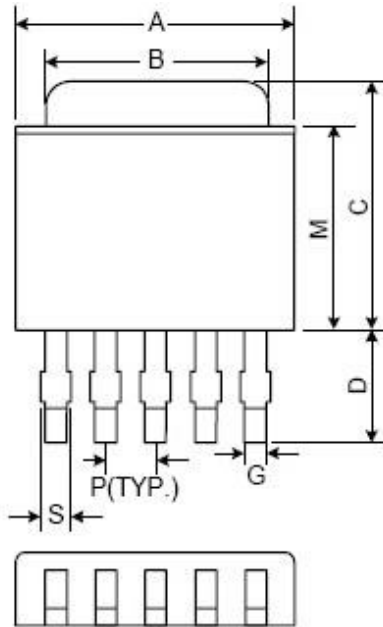

Figure11. XL6005 System Test Circuit (LED OVP)

Package Information

TO252-5L



Symbol	Dimensions In Millimeters			Dimensions In Inches		
	Min.	Nom.	Max.	Min.	Nom.	Max.
A	6.35	6.60	6.85	0.250	0.260	0.270
B	5.20	5.35	5.50	0.205	0.211	0.217
C	6.80	7.00	7.30	0.268	0.276	0.287
D	2.40	2.80	3.20	0.094	0.110	0.126
P	1.27 REF.			0.050 REF.		
S	0.50	0.65	0.80	0.020	0.026	0.031
G	0.40	0.50	0.63	0.016	0.020	0.025
H	2.20	2.30	2.40	0.087	0.091	0.094
J	0.45	0.52	0.58	0.018	0.020	0.023
K	0.00	0.08	0.15	0.000	0.003	0.006
L	0.90	1.20	1.63	0.035	0.047	0.064
M	5.40	5.80	6.20	0.213	0.228	0.244

180KHz 60V 4A Switching Current Boost LED Constant Current Driver**XL6005****Important Notice**

XLSEMI reserve the right to make modifications, enhancements, improvements, corrections or other changes without notice at any time. XLSEMI does not assume any liability arising out of the application or use of any product described herein; neither does it convey any license under its patent rights, nor the rights of others. XLSEMI assumes no liability for applications assistance or the design of Buyers' products. Buyers are responsible for their products and applications using XLSEMI components. To minimize the risks associated with Buyers' products and applications, Buyers should provide adequate design and operating safeguards. XLSEMI warrants performance of its products to the specifications applicable at the time of sale, in accordance with the warranty in XLSEMI's terms and conditions of sale of semiconductor products. Testing and other quality control techniques are used to the extent XLSEMI deems necessary to support this warranty. Except where mandated by applicable law, testing of all parameters of each component is not necessarily performed. For the latest product information, go to www.xlsemi.com.