

Features

- Operation Voltage from 12V to 90V
- Maximum Duty Cycle up to 100%
- Minimum Drop Out 0.5V
- Adjust VOUT from 1.25V to 20V
- Max. IOUT=2.1A at VOUT=5V
- Max. IOUT=1A at VOUT=12V or 15V
- Max. output power less than 15W
- Fixed 150KHz Switching Frequency
- Internal Optimize HV Power MOSFET
- High efficiency up to 90%
- Excellent line and load regulation
- Built in output short Protection Function
- Built in current limit function
- TO220-7L package

Applications

- Ebike Controller Power Supply
- Telecom / Networking Equipment

General Description

The XL7036 is a 150KHz fixed frequency PWM buck (step-down) DC/DC converter, capable of driving a 2.1A load with high efficiency, low ripple and excellent line and load regulation. Requiring a minimum number of external components, the regulator is simple to use and include internal frequency compensation and a fixed-frequency oscillator.

The PWM control circuit is able to adjust the duty ratio linearly from 0 to 100%.



Figure1. Package Type of XL7036

Pin Configurations

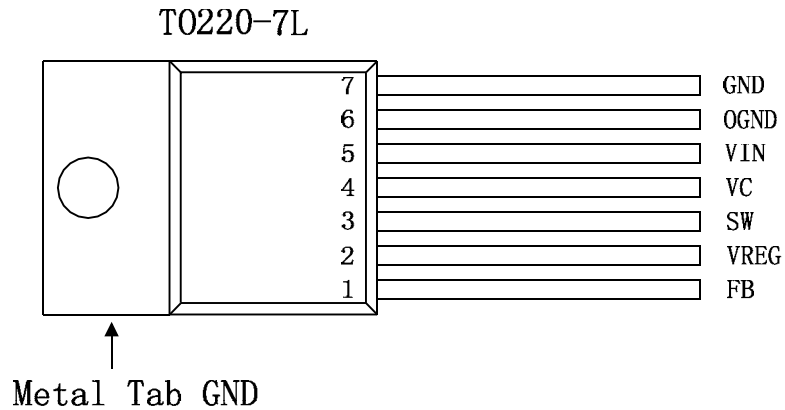

Figure2. Pin Configuration of XL7036 (Top View)

Table 1 Pin Description

Pin Number	Pin Name	Description
1	FB	Feedback Pin (FB). Through an external resistor divider network, Feedback senses the output voltage and regulates it. The feedback threshold voltage is 1.25V.
2	VREG	Supply Voltage Input Pin. A 10 μ F ceramic decoupling capacitor is required. An external voltage between 7V and 9V can be applied to this pin to reduce internal power dissipation.
3	SW	Power Switch Output Pin (SW). Output is the switch node that supplies power to the output.
4	VC	Internal Voltage Regulator Bypass Capacity. In typical system application, The VC pin connect a 1 μ F capacitor to VIN.
5	VIN	Supply Voltage Input Pin. XL7036 operates from 12V to 90V DC voltage. Bypass Vin to GND with a suitably large capacitor to eliminate noise on the input.
6	OGND	Output Ground Pin.
7	GND	Ground Pin. Care must be taken in layout. This pin should be placed outside of the Schottky Diode to output capacitor ground path to prevent switching current spikes from inducing voltage noise into XL7036. The exposed PAD is GND.

Function Block

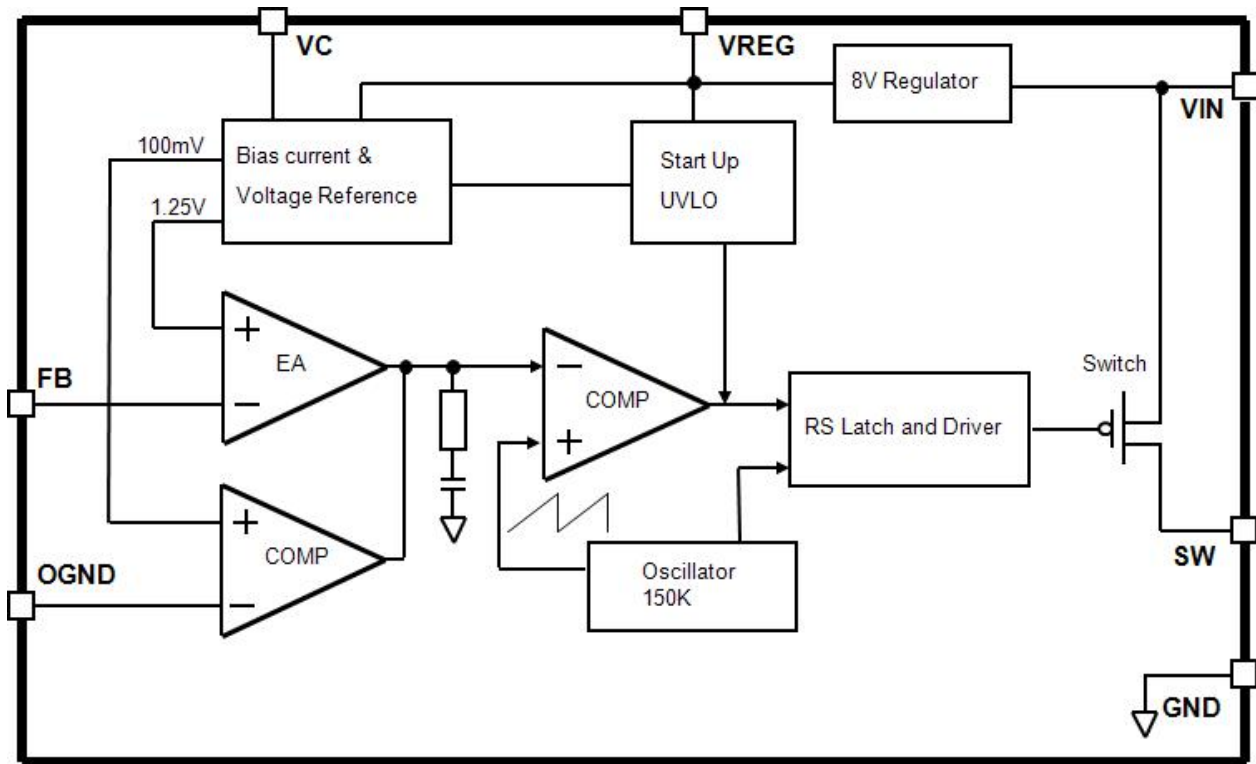
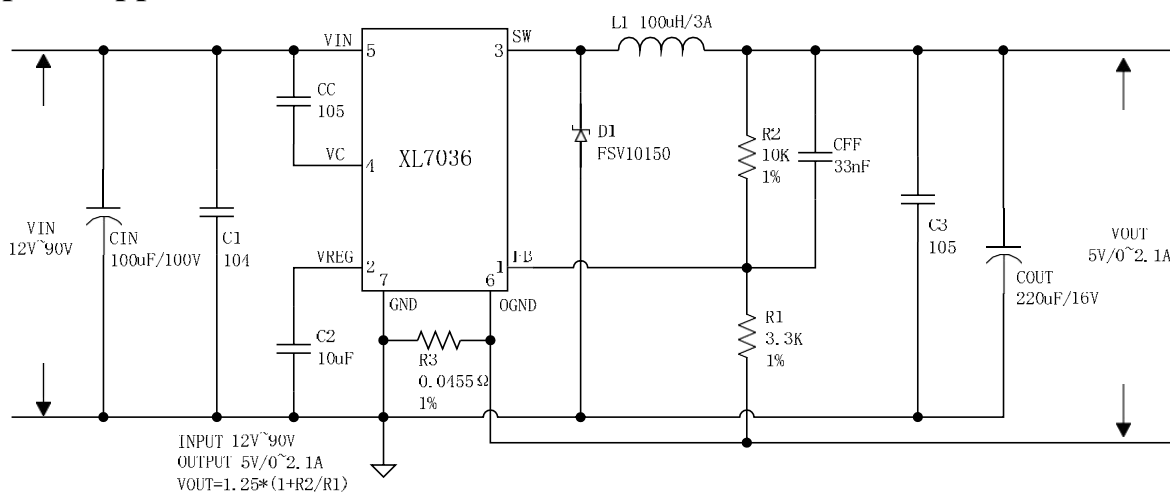

Figure3. Function Block Diagram of XL7036

Typical Application Circuit



R3 for limit maximum output current, R3 choose 45.5 mohm in $V_{OUT} \leq 5V$ application; R3 choose 91 mohm in $V_{OUT} > 5V$ application.

Figure4. XL7036 Typical Application Circuit

2.1A 150KHz 100V Buck DC to DC Converter

XL7036

Ordering Information

Order Information	Marking ID	Package Type	Packing Type Supplied As
XL7036E1	XL7036E1	TO220-7L	50 Units Per Tube

XLSEMI Pb-free products, as designated with “E1” suffix in the par number, are RoHS compliant.

Absolute Maximum Ratings (Note1)

Parameter	Symbol	Value	Unit
VIN Pin Voltage	V _{in}	-0.3 to 100	V
FB Pin Voltage	V _{FB}	-0.3 to V _{in}	V
SW Pin Voltage	V _{SW}	-0.3 to V _{in}	V
Power Dissipation	P _D	Internally limited	mW
Thermal Resistance (TO220-7L) (Junction to Ambient, No Heatsink, Free Air)	R _{JA}	30	°C/W
Maximum Junction Temperature	T _J	-40 to 150	°C
Operating Junction Temperature	T _J	-40 to 125	°C
Storage Temperature	T _{STG}	-65 to 150	°C
Lead Temperature (Soldering, 10 sec)	T _{LEAD}	260	°C
ESD (HBM)		>3000	V

Note1: Stresses greater than those listed under Maximum Ratings may cause permanent damage to the device. This is a stress rating only and functional operation of the device at these or any other conditions above those indicated in the operation is not implied. Exposure to absolute maximum rating conditions for extended periods may affect reliability.

XL7036 Electrical Characteristics

$T_a = 25^\circ\text{C}$; unless otherwise specified.

Symbol	Parameter	Test Condition	Min.	Typ.	Max.	Unit
<i>System parameters test circuit figure4</i>						
VFB	FB Voltage	$V_{in} = 20\text{V to } 90\text{V}$, $V_{out} = 15\text{V}$ $I_{load} = 0.1\text{A to } 1\text{A}$	1.225	1.25	1.275	V
η	Efficiency	$V_{in} = 24\text{V}$, $V_{out} = 15\text{V}$ $I_{out} = 1\text{A}$	-	94	-	%
η	Efficiency	$V_{in} = 36\text{V}$, $V_{out} = 15\text{V}$ $I_{out} = 1\text{A}$	-	93	-	%
η	Efficiency	$V_{in} = 48\text{V}$, $V_{out} = 15\text{V}$ $I_{out} = 1\text{A}$	-	91	-	%
η	Efficiency	$V_{in} = 60\text{V}$, $V_{out} = 15\text{V}$ $I_{out} = 1\text{A}$	-	89	-	%
η	Efficiency	$V_{in} = 72\text{V}$, $V_{out} = 15\text{V}$ $I_{out} = 1\text{A}$	-	87	-	%

Electrical Characteristics (DC Parameters)

$V_{in} = 48\text{V}$, $GND = 0\text{V}$, V_{in} & GND parallel connect a $33\mu\text{f}/100\text{V}$ capacitor; $I_{out} = 0.2\text{A}$, $T_a = 25^\circ\text{C}$; the others floating unless otherwise specified.

Parameters	Symbol	Test Condition	Min.	Typ.	Max.	Unit
Input operation voltage	V_{in}		12		90	V
VIN UVLO	V_{in_uvlo}			10	11	V
VREG voltage	V_{reg}			8		V
Quiescent Supply Current	I_q	$V_{FB} = 2\text{V}$		2.5	5	mA
Oscillator Frequency	F_{osc}		120	150	180	KHz
Switch Current Limit	I_L	$V_{FB} = 0$, $R_3 = 0.045\ \Omega$		2.22		A
Output Power PMOS	R_{dson}	$V_{in} = 48\text{V}$, $I_{sw} = 0.3\text{A}$		160	200	mohm
Max. Duty Cycle	D_{MAX}	$V_{FB} = 0\text{V}$		100		%

Typical Performance Characteristics

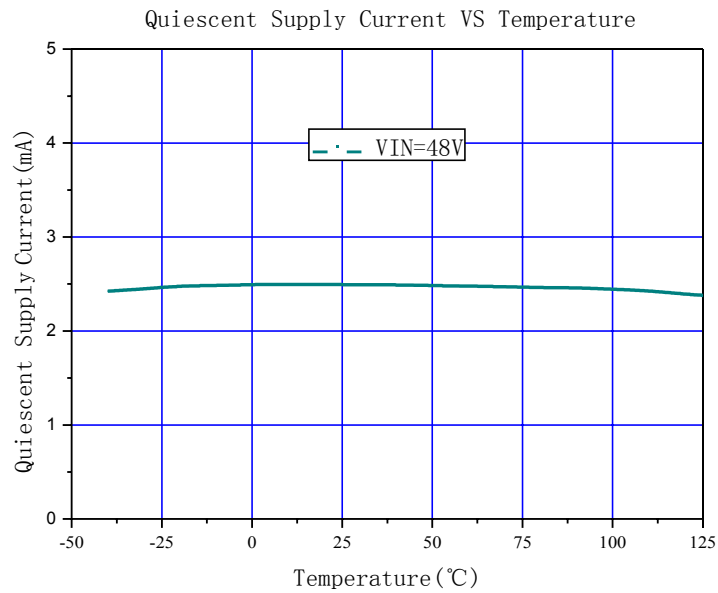

Figure5. Quiescent Current Curve

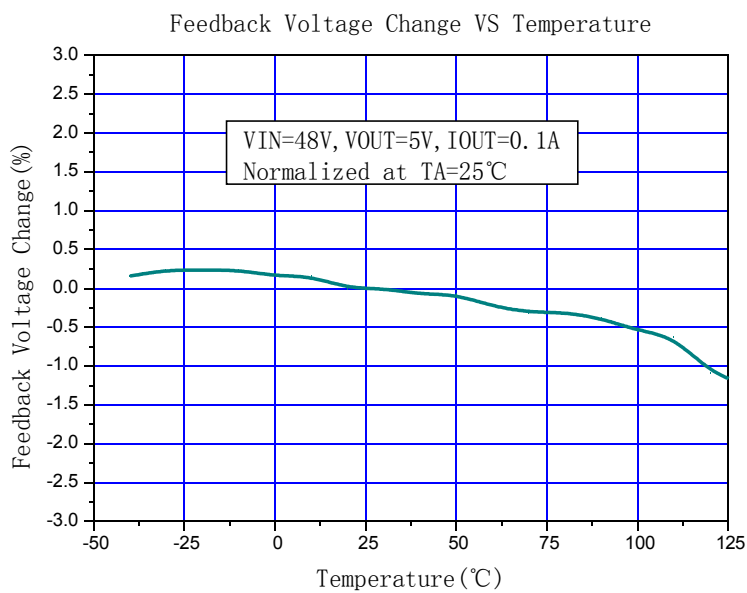

Figure6. Feedback Voltage Curve

Typical System Application (VOUT=15V, IOU=0~1A)

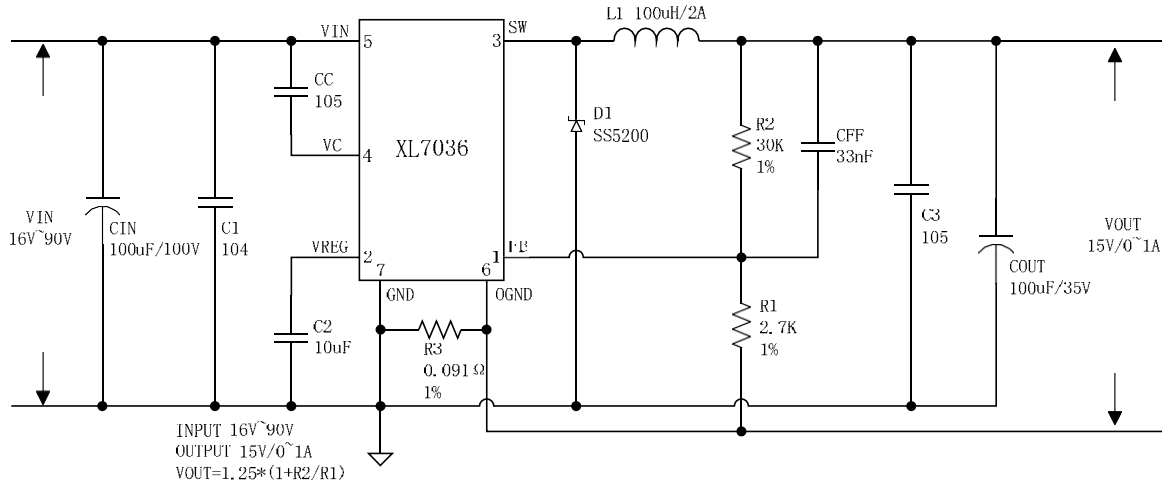

Figure7. XL7036 System Application (VIN=16V~90V, VOUT=15V, IOU=0~1A)

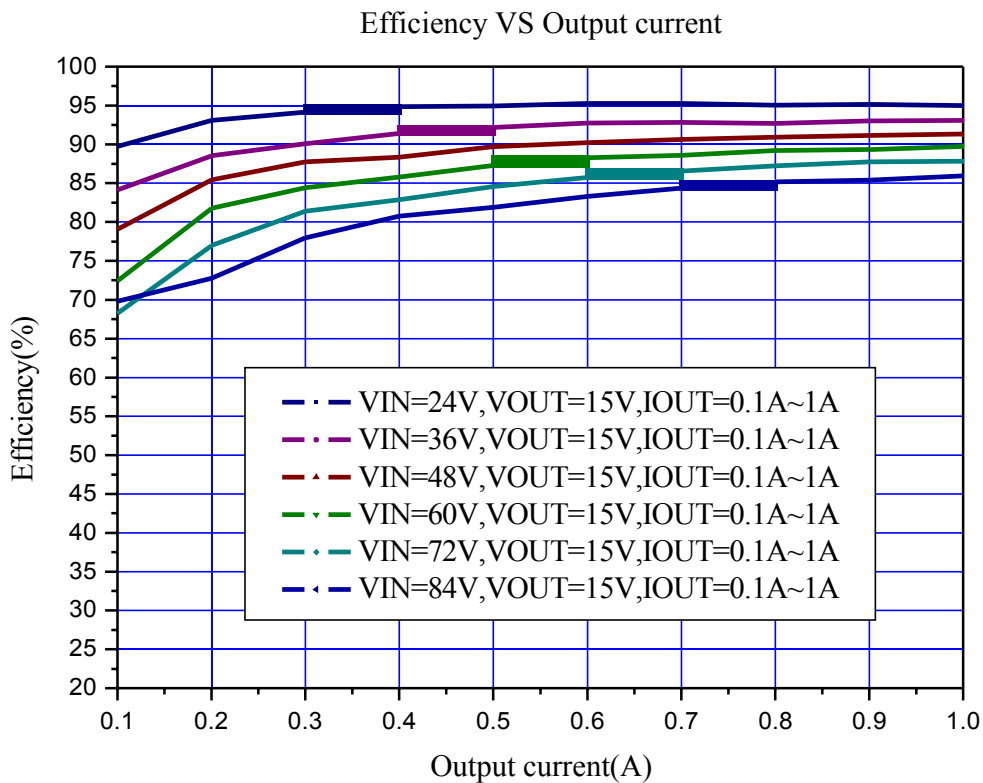

Figure8. XL7036 System Application (Efficiency VS Output Current)

Typical System Application (VOUT=5V, IOU=0~2.1A)

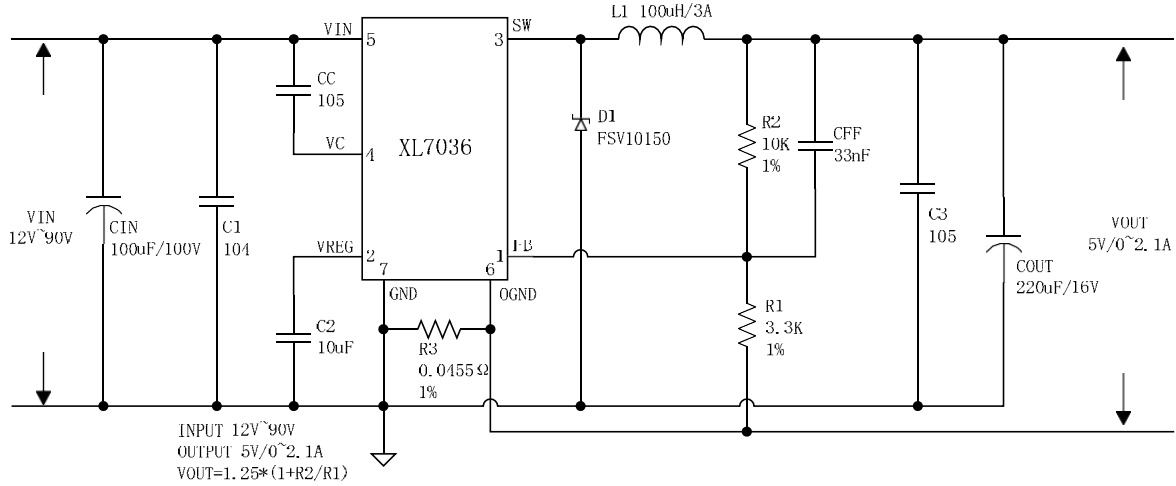

Figure9. XL7036 System Application (VIN=12V~90V, VOUT=5V, IOU=0~2.1A)

Efficiency VS Output current

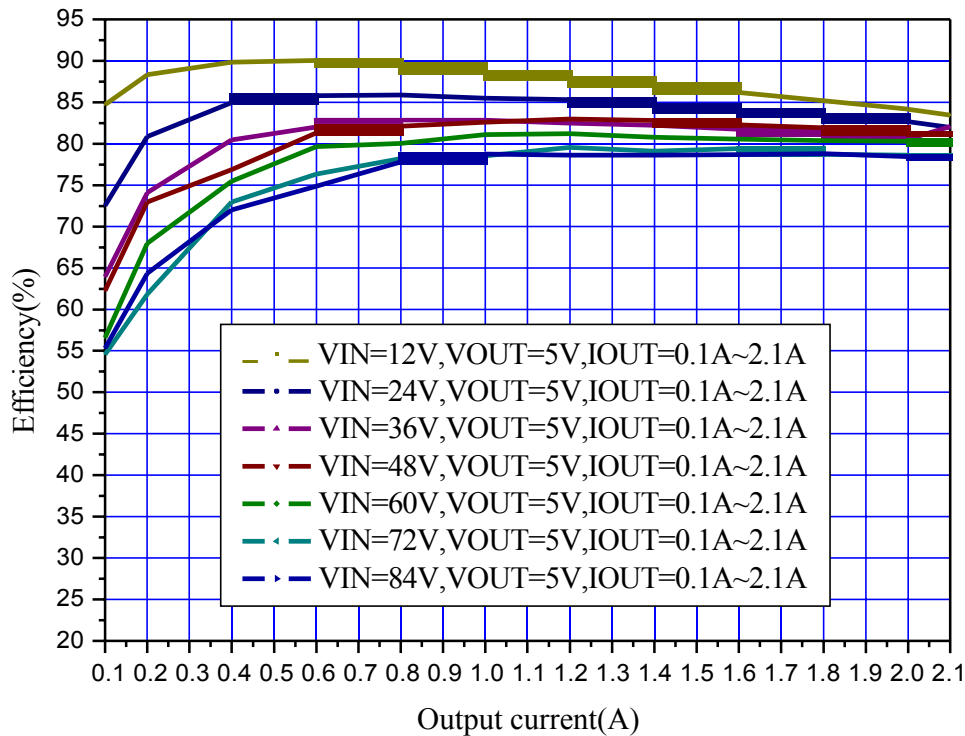
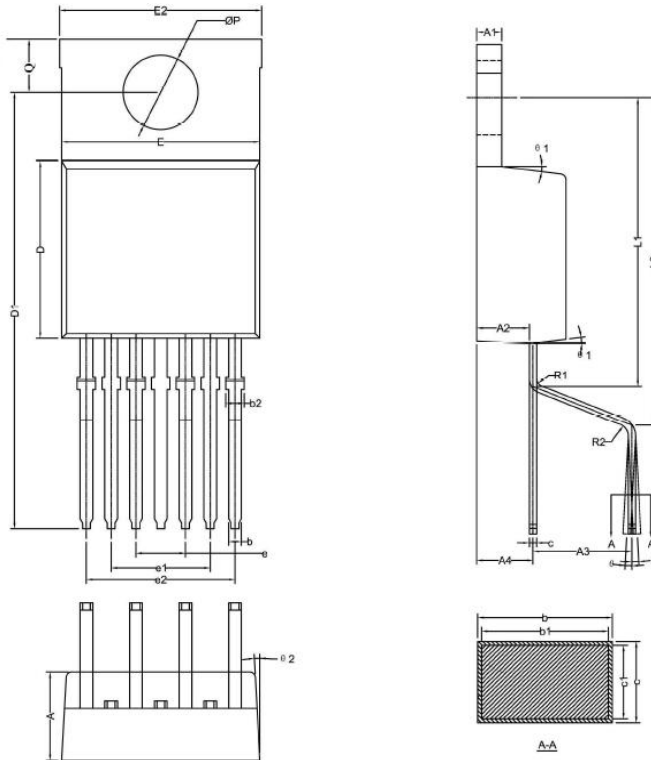

Figure10. XL7036 System Application (Efficiency VS Output Current)

Package Information

Package Information (TO220-7L)



Symbol	Dimensions In Millimeters		
	Min	Nom	Max
A	4.15	4.30	4.45
A1	-	1.30	-
A2	2.40	2.50	2.60
A3	4.88	5.08	5.28
A4	2.49	2.69	2.89
b	0.61	-	0.74
b1	0.60	0.65	0.70
b2	0.61	-	0.90
c	-	0.46	-
c1	-	0.45	-
D	8.50	8.60	8.70
D1	22.37	22.62	22.89
E	10.06	10.16	10.26
E2	10.05	-	10.40
e	2.44	2.54	2.64
e1	4.98	5.08	5.18
e2	7.52	7.62	7.72
L1	14.62	14.92	15.22
L2	16.67	16.97	17.27
Q	2.60	2.75	2.90
θ	0		6°
θ1	5°	7°	9°
θ2	1°	3°	5°
P	3.79	3.84	3.89

Important Notice

XLSEMI reserve the right to make modifications, enhancements, improvements, corrections or other changes without notice at any time. XLSEMI does not assume any liability arising out of the application or use of any product described herein; neither does it convey any license under its patent rights, nor the rights of others. XLSEMI assumes no liability for applications assistance or the design of Buyers' products. Buyers are responsible for their products and applications using XLSEMI components. To minimize the risks associated with Buyers' products and applications, Buyers should provide adequate design and operating safeguards. XLSEMI warrants performance of its products to the specifications applicable at the time of sale, in accordance with the warranty in XLSEMI's terms and conditions of sale of semiconductor products. Testing and other quality control techniques are used to the extent XLSEMI deems necessary to support this warranty. Except where mandated by applicable law, testing of all parameters of each component is not necessarily performed. For the latest product information, go to www.xlsemi.com.