

180KHz 60V 5A Switching Current Boost DC/DC Converter

XL6012

Features

- Wide 5V to 40V Input Voltage Range
- Maximum Boost Output Up to 60V
- Current Mode Control Provides Excellent Transient Response
- 1.25V reference adjustable version
- Fixed 180KHz Switching Frequency
- Maximum 5A Switching Current
- SW PIN Built in Over Voltage Protection
- Excellent line and load regulation
- EN PIN TTL shutdown capability
- Internal Optimize Power MOSFET
- High efficiency up to 94%
- Built in Frequency Compensation
- Built in Soft-Start Function
- Built in Thermal Shutdown Function
- Built in Current Limit Function
- Available in TO220-5L package

Applications

- EPC / Notebook Car Adapter
- Automotive and Industrial Boost / Buck-Boost / Inverting Converters
- Portable Electronic Equipment

General Description

The XL6012 regulator is a wide input range, current mode, DC/DC converter which is can be configured as either a boost, flyback, SEPIC or inverting converter. The XL6012 built in high voltage N-channel power MOSFET and fixed frequency oscillator, current-mode architecture results in stable operation over a wide range of supply and output voltages.

The XL6012 regulator is special design for portable electronic equipment applications.

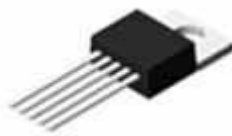

Figure1. Package Type of XL6012

Pin Configurations

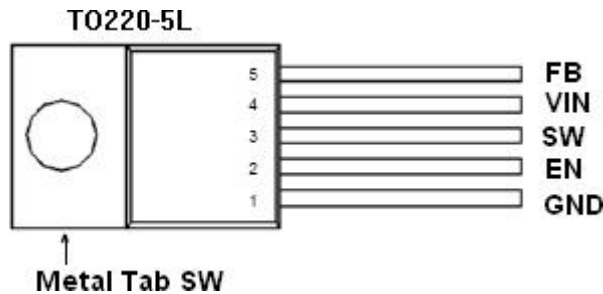

Figure2. Pin Configuration of XL6012 (Top View)

Table 1 Pin Description

Pin Number	Pin Name	Description
1	GND	Ground Pin.
2	EN	Enable Pin. Drive EN pin low to turn off the device, drive it high to turn it on. Floating is default high.
3	SW	Power Switch Output Pin (SW).
4	VIN	Supply Voltage Input Pin. XL6012 operates from a 5V to 40V DC voltage. Bypass Vin to GND with a suitably large capacitor to eliminate noise on the input.
5	FB	Feedback Pin (FB). Through an external resistor divider network, FB senses the output voltage and regulates it. The feedback threshold voltage is 1.25V.

Function Block

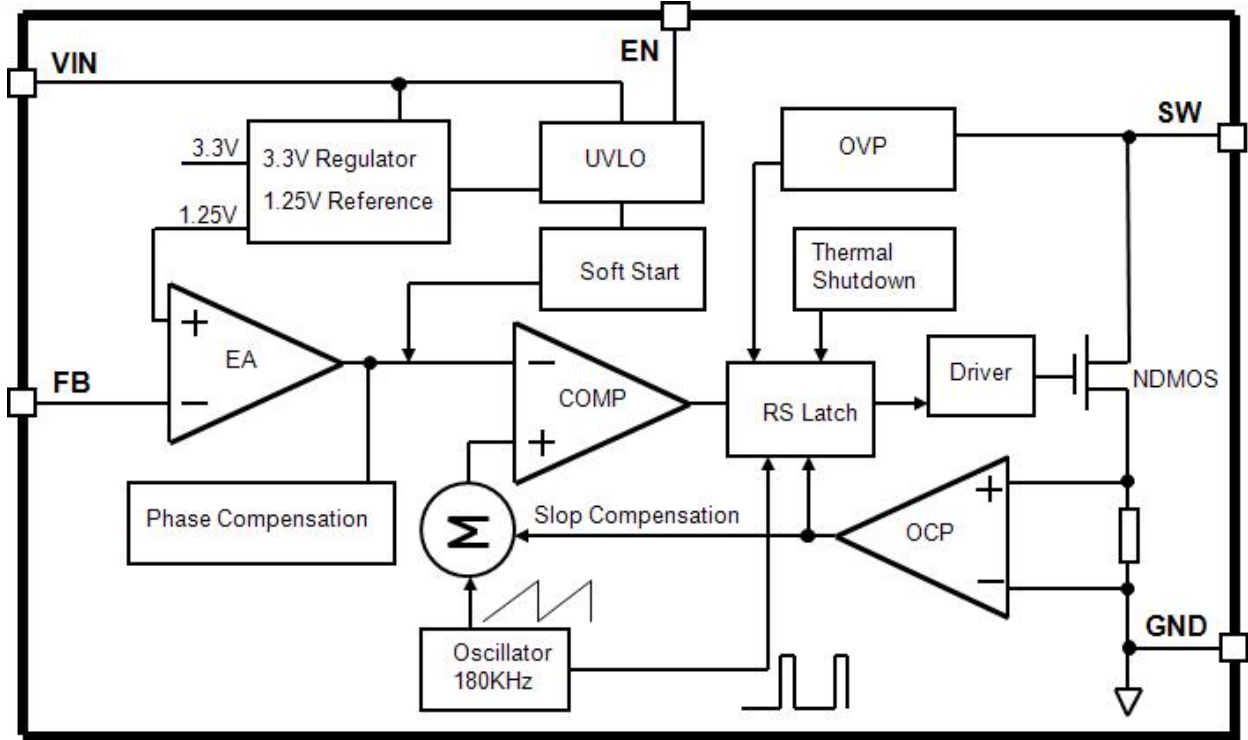

Figure3. Function Block Diagram of XL6012

Typical Application Circuit

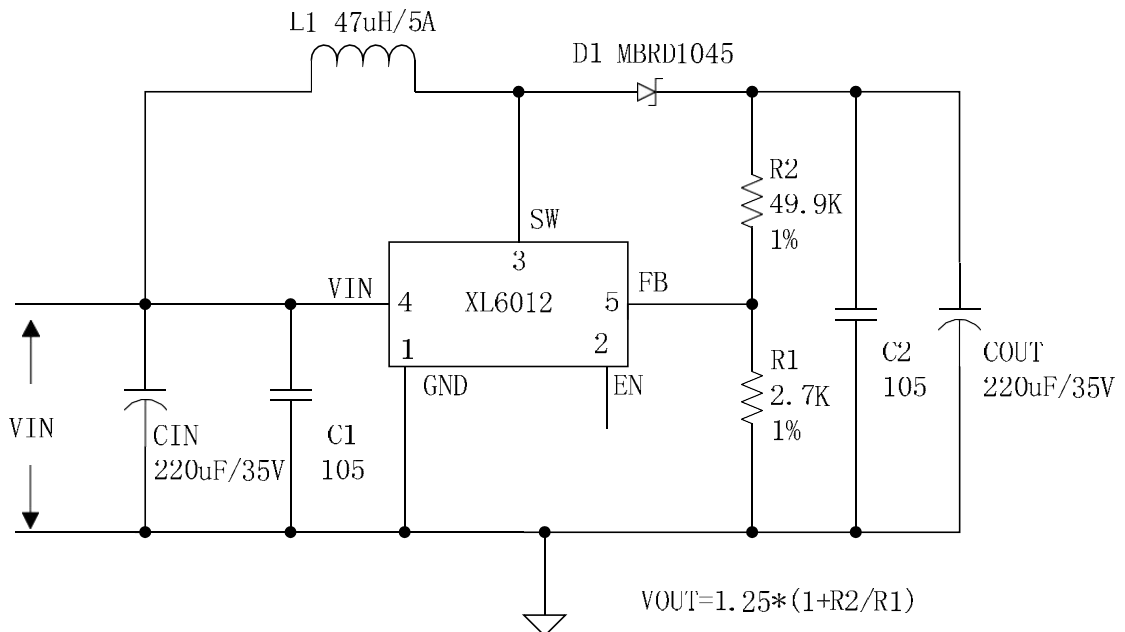

Figure4. XL6012 Typical Application Circuit

180KHz 60V 5A Switching Current Boost DC/DC Converter

XL6012

Ordering Information

Order Information	Marking ID	Package Type	Packing Type Supplied As
XL6012E1	XL6012E1	TO220-5L	50 Units Per Tube

XLSEMI Pb-free products, as designated with “E1” suffix in the par number, are RoHS compliant.

Absolute Maximum Ratings (Note1)

Parameter	Symbol	Value	Unit
Input Voltage	V_{in}	-0.3 to 45	V
Feedback Pin Voltage	V_{FB}	-0.3 to V_{in}	V
EN Pin Voltage	V_{EN}	-0.3 to V_{in}	V
Output Switch Pin Voltage	V_{Output}	-0.3 to 60	V
Power Dissipation	P_D	Internally limited	mW
Thermal Resistance (TO220-5L) (Junction to Ambient, No Heatsink, Free Air)	R_{JA}	30	°C/W
Maximum Junction Temperature	T_J	-40 to 150	°C
Operating Junction Temperature	T_J	-40 to 125	°C
Storage Temperature	T_{STG}	-65 to 150	°C
Lead Temperature (Soldering, 10 sec)	T_{LEAD}	260	°C
ESD (HBM)		>2000	V

Note1: Stresses greater than those listed under Maximum Ratings may cause permanent damage to the device. This is a stress rating only and functional operation of the device at these or any other conditions above those indicated in the operation is not implied. Exposure to absolute maximum rating conditions for extended periods may affect reliability.

180KHz 60V 5A Switching Current Boost DC/DC Converter

XL6012

XL6012 Electrical Characteristics

$T_a = 25^\circ\text{C}$; unless otherwise specified.

Symbol	Parameter	Test Condition	Min.	Typ.	Max.	Unit
<i>System parameters test circuit figure4</i>						
VFB	Feedback Voltage	$V_{in} = 12\text{V to } 20\text{V}, V_{out}=24\text{V}$ $I_{load}=0.1\text{A to } 1\text{A}$	1.213	1.25	1.287	V
Efficiency	η	$V_{in}=12\text{V}, V_{out}=24\text{V}$ $I_{out}=1\text{A}$	-	93	-	%

Electrical Characteristics (DC Parameters)

$V_{in} = 12\text{V}$, $GND=0\text{V}$, V_{in} & GND parallel connect a 220uf/50V capacitor; $I_{out}=0.5\text{A}$, $T_a = 25^\circ\text{C}$; the others floating unless otherwise specified.

Parameters	Symbol	Test Condition	Min.	Typ.	Max.	Unit
Input operation voltage	V_{in}		5		40	V
Shutdown Supply Current	I_{STBY}	$V_{EN}=0\text{V}$		70	100	μA
Quiescent Supply Current	I_q	$V_{EN} = 2\text{V},$ $V_{FB} = V_{in}$		3.5	5	mA
Oscillator Frequency	F_{osc}		144	180	216	KHz
SW OVP	V_{SW}	$V_{FB} = 0\text{V}$		60		V
Switch Current Limit	I_L	$V_{FB} = 0$		5		A
Output Power NMOS	R_{dson}	$V_{in}=12\text{V},$ $I_{SW}=5\text{A}$		35	40	mohm
EN Pin Threshold	V_{EN}	High (Regulator ON)		1.4		V
		Low (Regulator OFF)		0.8		
EN Pin Input Leakage Current	I_H	$V_{EN} = 2\text{V (ON)}$		3	10	μA
	I_L	$V_{EN} = 0\text{V (OFF)}$		3	10	μA
Max. Duty Cycle	D_{MAX}	$V_{FB}=0\text{V}$		90		%

Typical System Application (Recommend output current safe work range)

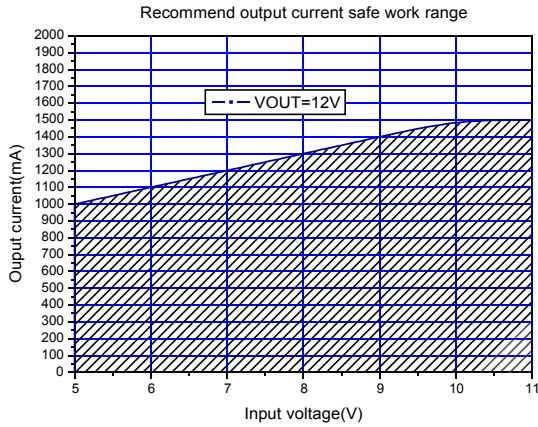

Figure5.Max output current (VOUT=12V)

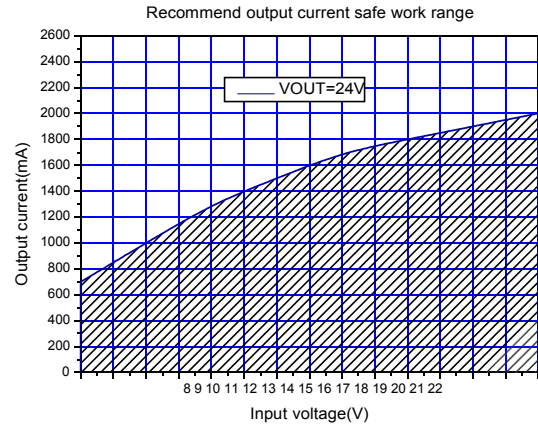

Figure6.Max output current (VOUT=24V)

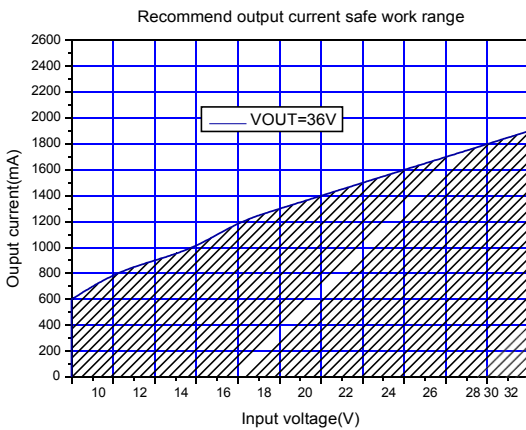

Figure7.Max output current (VOUT=36V)

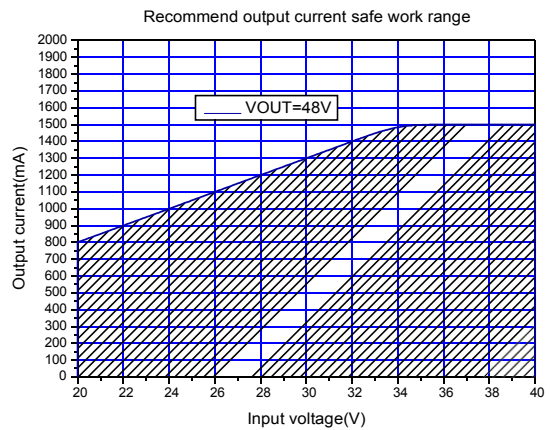

Figure8.Max output current(VOUT=48V)

Typical Performance Characteristics

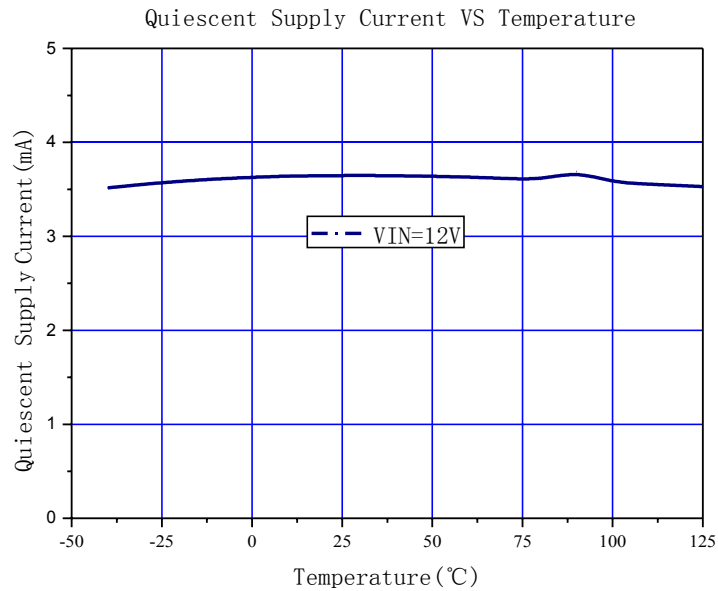

Figure9. Quiescent Current Curve

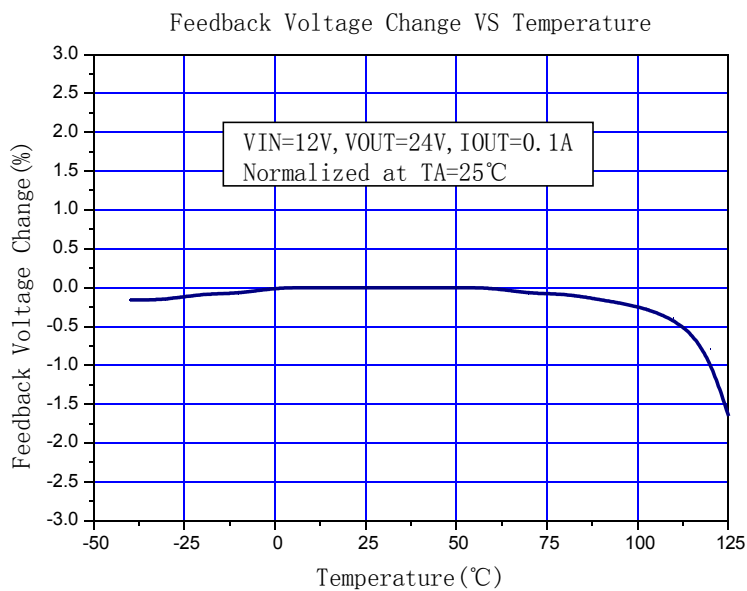

Figure10. Feedback Voltage Curve

Typical System Application(VIN=12V,VOUT=24V)

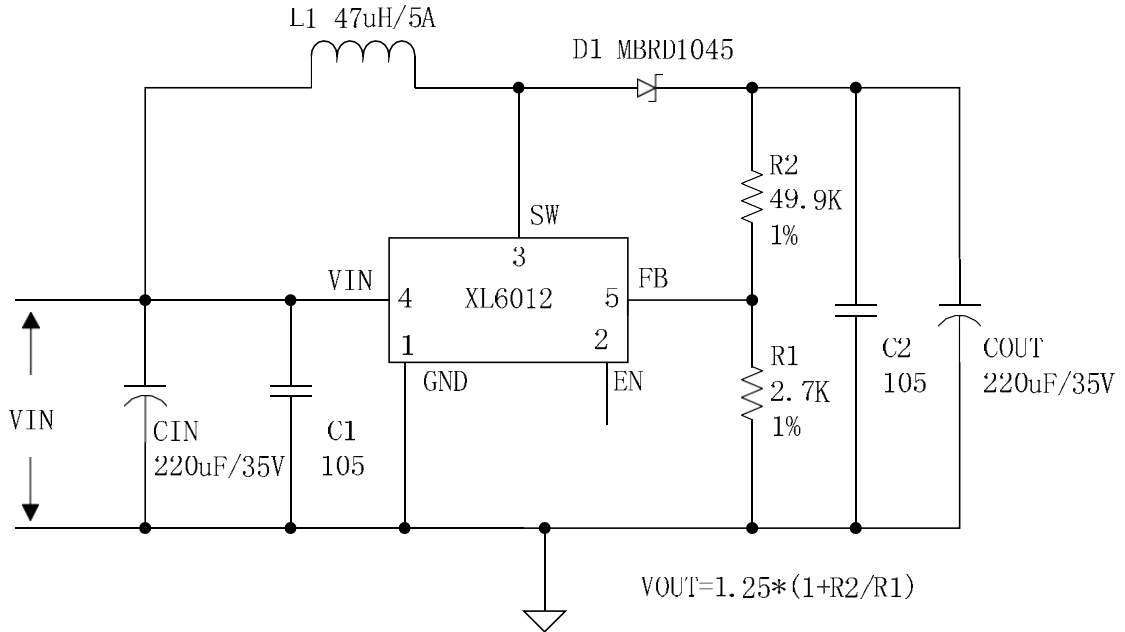

Figure11. XL6012 Typical System Application(VIN=12V, VOUT=24V)

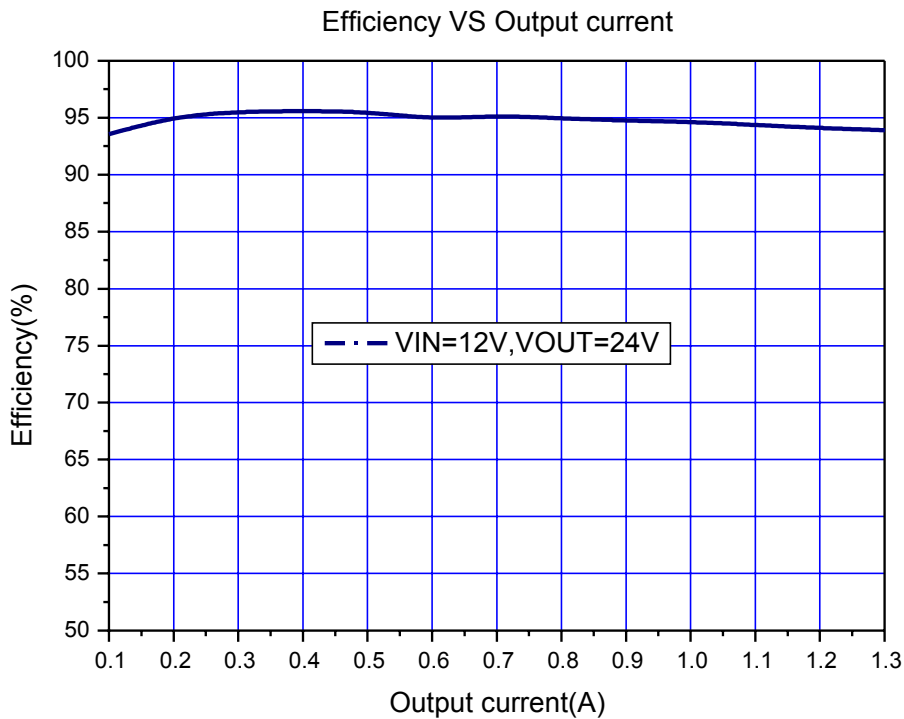

Figure12. XL6012 System Efficiency Curve (VIN=12V, VOUT=24V)

Typical System Application(VIN=5V,VOUT=12V)

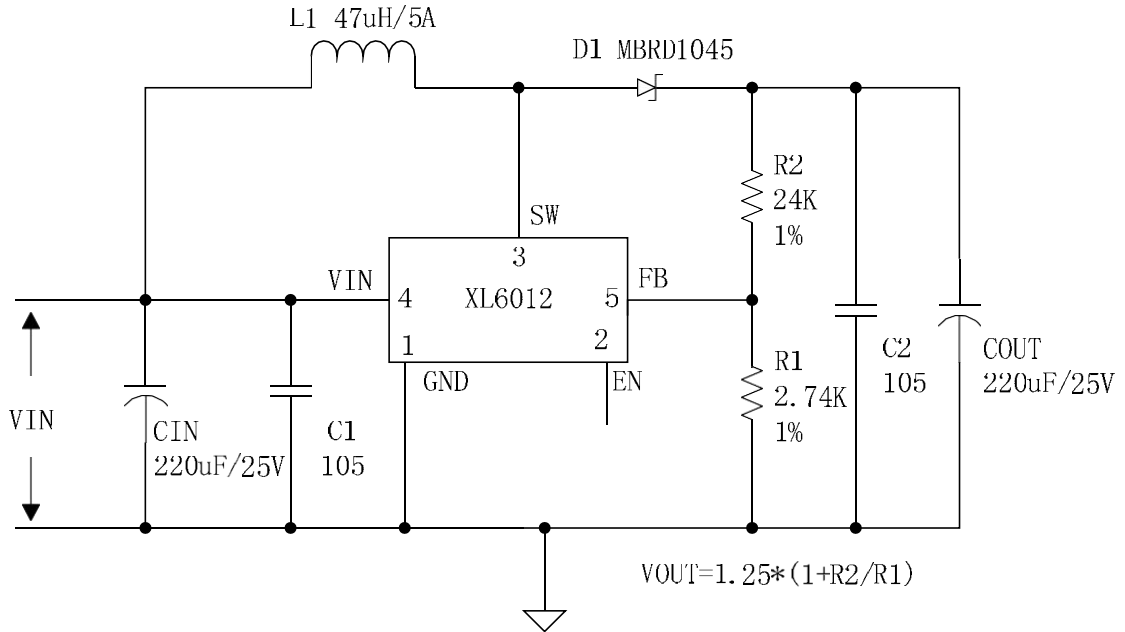

Figure13. XL6012 Typical System Application (VIN=5V,VOUT=12V)

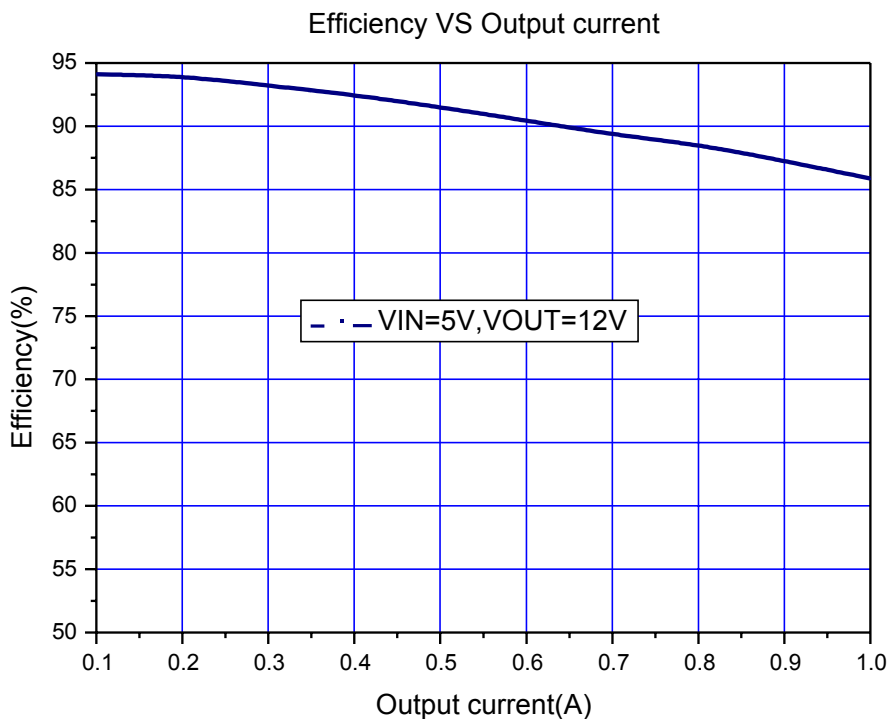

Figure14. XL6012 System Efficiency Curve (VIN=5V, VOUT=12V)

Typical System Application(VIN=10~32V,VOUT=36V)

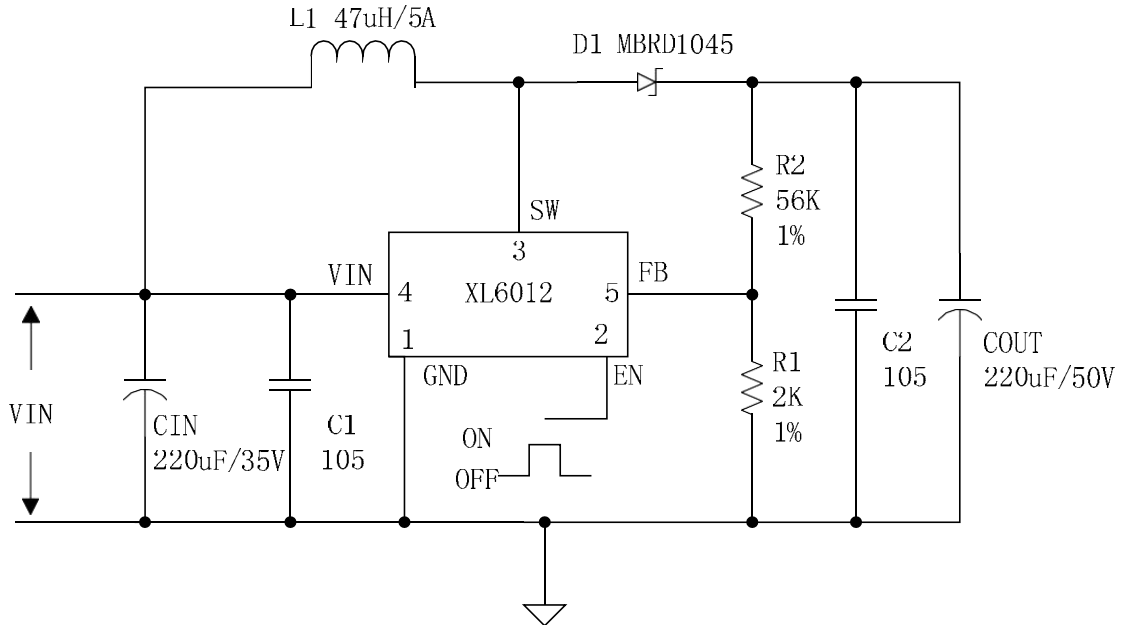

Figure15. XL6012 Typical System Application (VIN=10~32V,VOUT=36V)

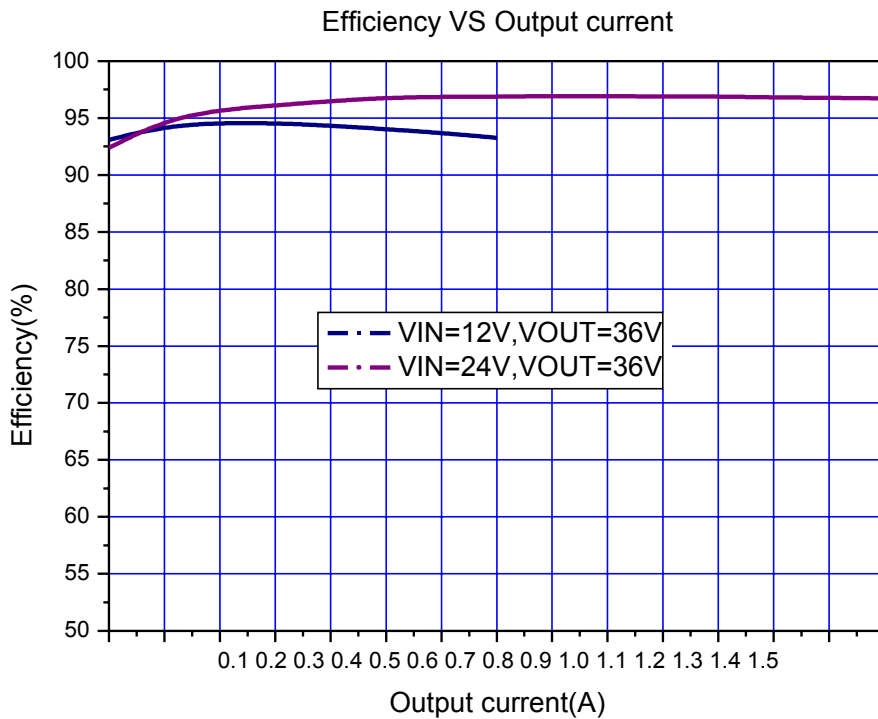

Figure16. XL6012 System Efficiency Curve (VIN=10~32V, VOUT=36V)

Typical System Application(VIN=20~40V,VOUT=48V)

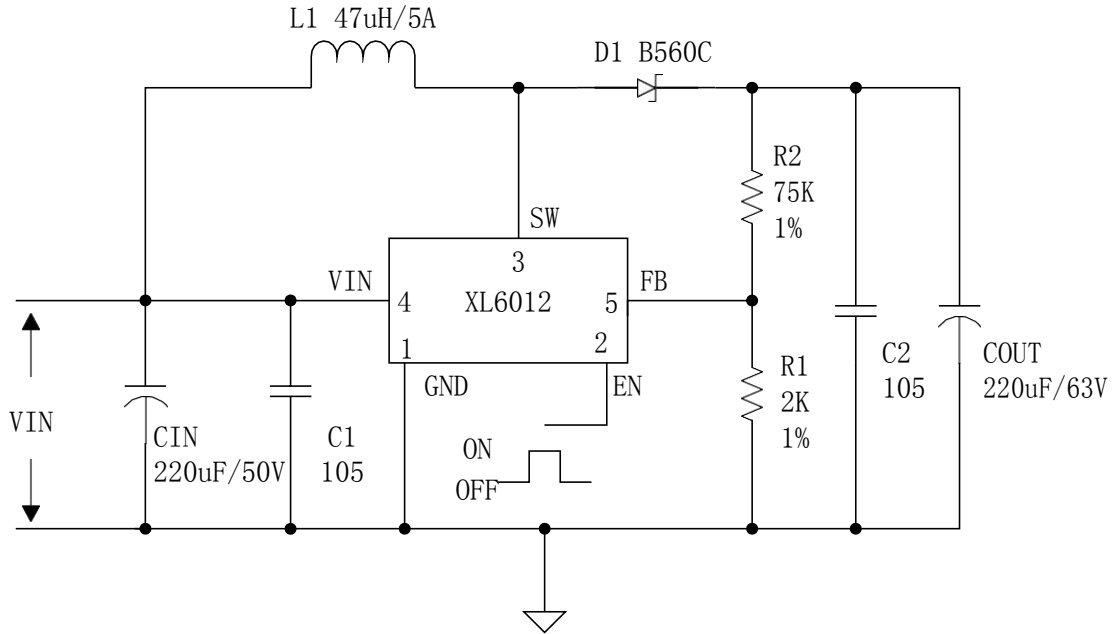

Figure17. XL6012 Typical System Application (VIN=20~40V,VOUT=48V)

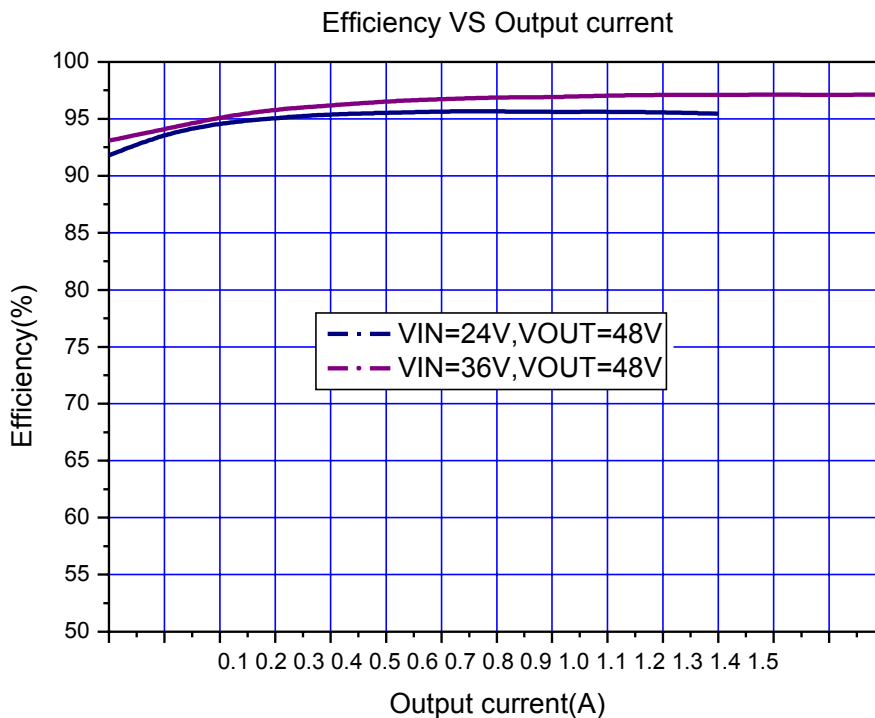

Figure18. XL6012 System Efficiency Curve (VIN=20~40V, VOUT=48V)

Typical System Application(VIN=10~30V,VOUT=12V)

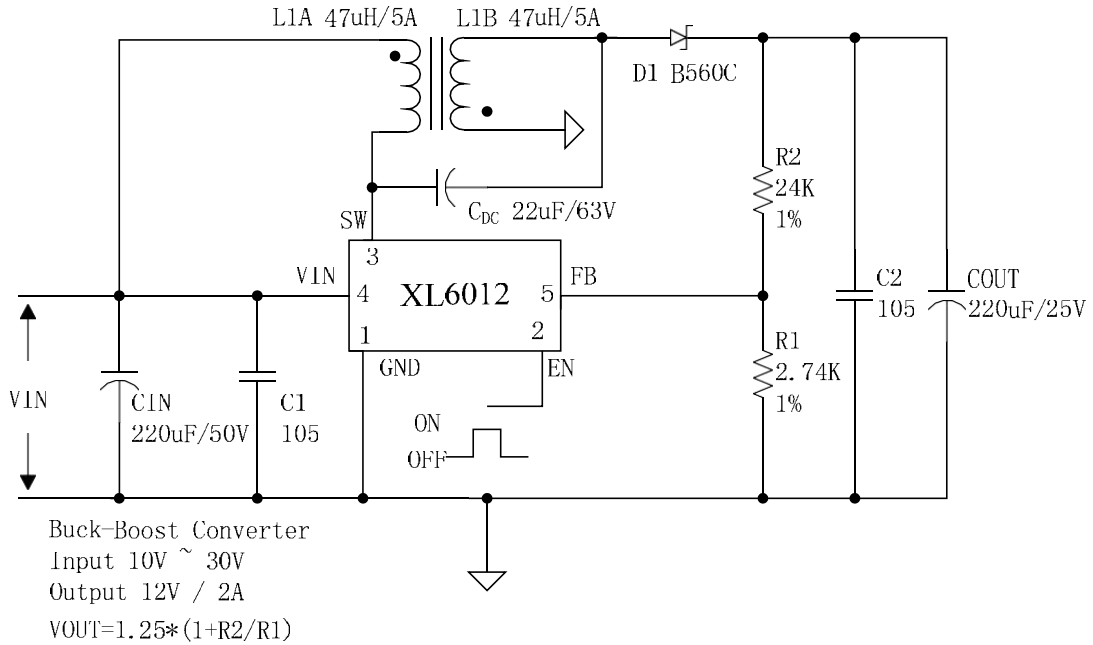
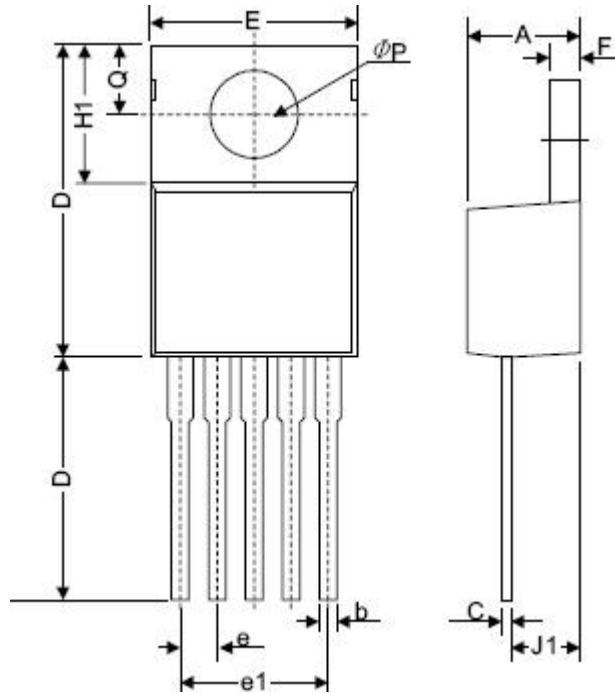

Figure19. XL6012 Typical System Application (VIN=10~30V,VOUT=12V)

Package Information

TO220-5L



Symbol	Dimensions In Millimeters		Dimensions In Inches	
	Min.	Max.	Min.	Max.
A	4.06	4.83	0.160	0.190
b	0.76	1.02	0.030	0.040
C	0.36	0.64	0.014	0.025
D	14.22	15.49	0.560	0.610
E	9.78	10.54	0.385	0.415
e	1.57	1.85	0.062	0.073
e(1)	6.68	6.93	0.263	0.273
F	1.14	1.40	0.045	0.055
H(1)	5.46	6.86	0.215	0.270
J(1)	2.29	3.18	0.090	0.125
L	13.21	14.73	0.520	0.580
ϕP	3.68	3.94	0.145	0.155
Q	2.54	2.92	0.100	0.115

180KHz 60V 5A Switching Current Boost DC/DC Converter**XL6012****Important Notice**

XLSEMI reserve the right to make modifications, enhancements, improvements, corrections or other changes without notice at any time. XLSEMI does not assume any liability arising out of the application or use of any product described herein; neither does it convey any license under its patent rights, nor the rights of others. XLSEMI assumes no liability for applications assistance or the design of Buyers' products. Buyers are responsible for their products and applications using XLSEMI components. To minimize the risks associated with Buyers' products and applications, Buyers should provide adequate design and operating safeguards. XLSEMI warrants performance of its products to the specifications applicable at the time of sale, in accordance with the warranty in XLSEMI's terms and conditions of sale of semiconductor products. Testing and other quality control techniques are used to the extent XLSEMI deems necessary to support this warranty. Except where mandated by applicable law, testing of all parameters of each component is not necessarily performed. For the latest product information, go to www.xlsemi.com.