

180KHz 60V 5A Switching Current Boost / Buck-Boost / Inverting DC/DC Converter**Features**

- Wide 5V to 40V Input Voltage Range
- Positive or Negative Output Voltage Programming with a Single Feedback Pin
- Current Mode Control Provides Excellent Transient Response
- 1.25V reference adjustable version
- Fixed 180KHz Switching Frequency
- Maximum 5A Switching Current
- SW PIN Built in Over Voltage Protection
- Excellent line and load regulation
- EN PIN TTL shutdown capability
- Internal Optimize Power MOSFET
- High efficiency up to 94%
- Built in Frequency Compensation
- Built in Soft-Start Function
- Built in Thermal Shutdown Function
- Built in Current Limit Function
- Available in TO263-5L package

Applications

- EPC / Notebook Car Adapter
- Automotive and Industrial Boost / Buck-Boost / Inverting Converters
- Portable Electronic Equipment

General Description

The XL6019 regulator is a wide input range, current mode, DC/DC converter which is capable of generating either positive or negative output voltages. It can be configured as either a boost, flyback, SEPIC or inverting converter. The XL6019 built in N-channel power MOSFET and fixed frequency oscillator, current-mode architecture results in stable operation over a wide range of supply and output voltages.

The XL6019 regulator is special design for portable electronic equipment applications.

**TO263-5L**

Figure1. Package Type of XL6019

180KHz 60V 5A Switching Current Boost / Buck-Boost / Inverting DC/DC Converter

Pin Configurations

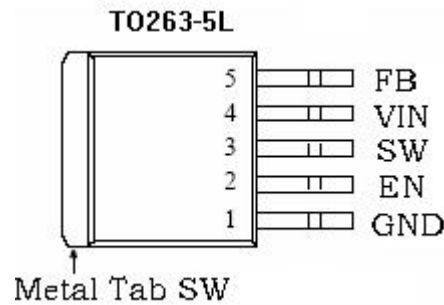

Figure2. Pin Configuration of XL6019 (Top View)

Table 1 Pin Description

Pin Number	Pin Name	Description
1	GND	Ground Pin.
2	EN	Enable Pin. Drive EN pin low to turn off the device, drive it high to turn it on. Floating is default high.
3	SW	Power Switch Output Pin (SW).
4	VIN	Supply Voltage Input Pin. XL6019 operates from a 5V to 40V DC voltage. Bypass Vin to GND with a suitably large capacitor to eliminate noise on the input.
5	FB	Feedback Pin (FB). Through an external resistor divider network, FB senses the output voltage and regulates it. The feedback threshold voltage is 1.25V.

180KHz 60V 5A Switching Current Boost / Buck-Boost / Inverting DC/DC Converter

Function Block

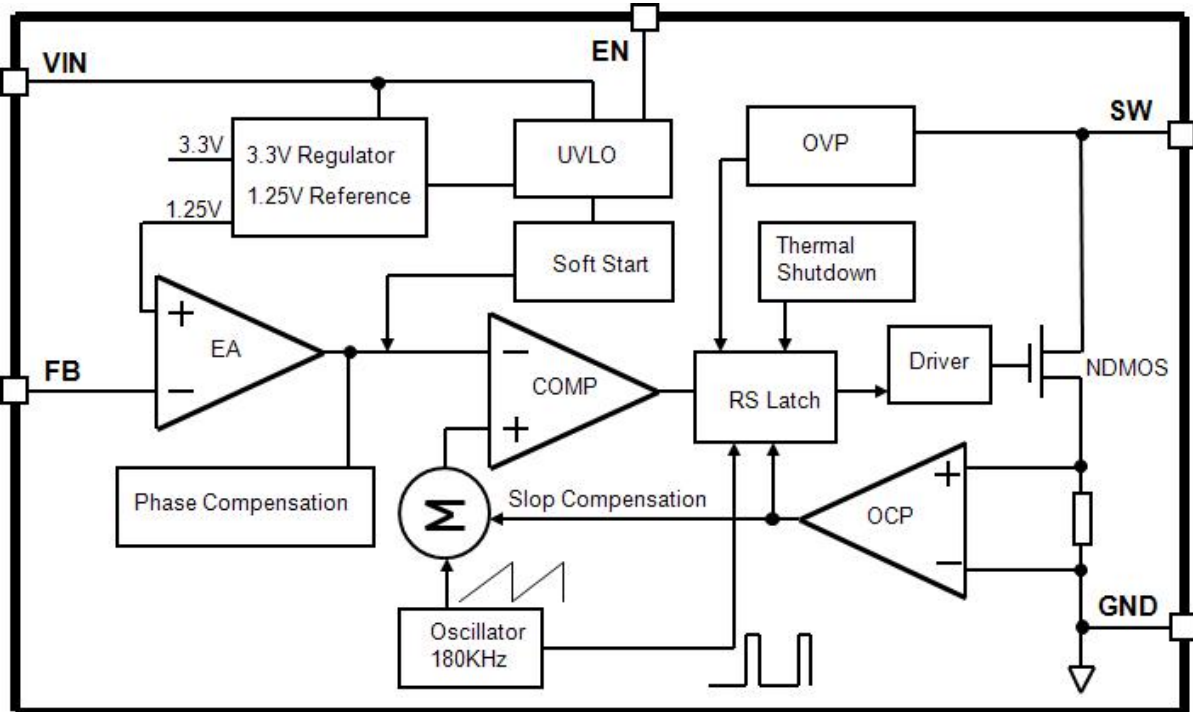
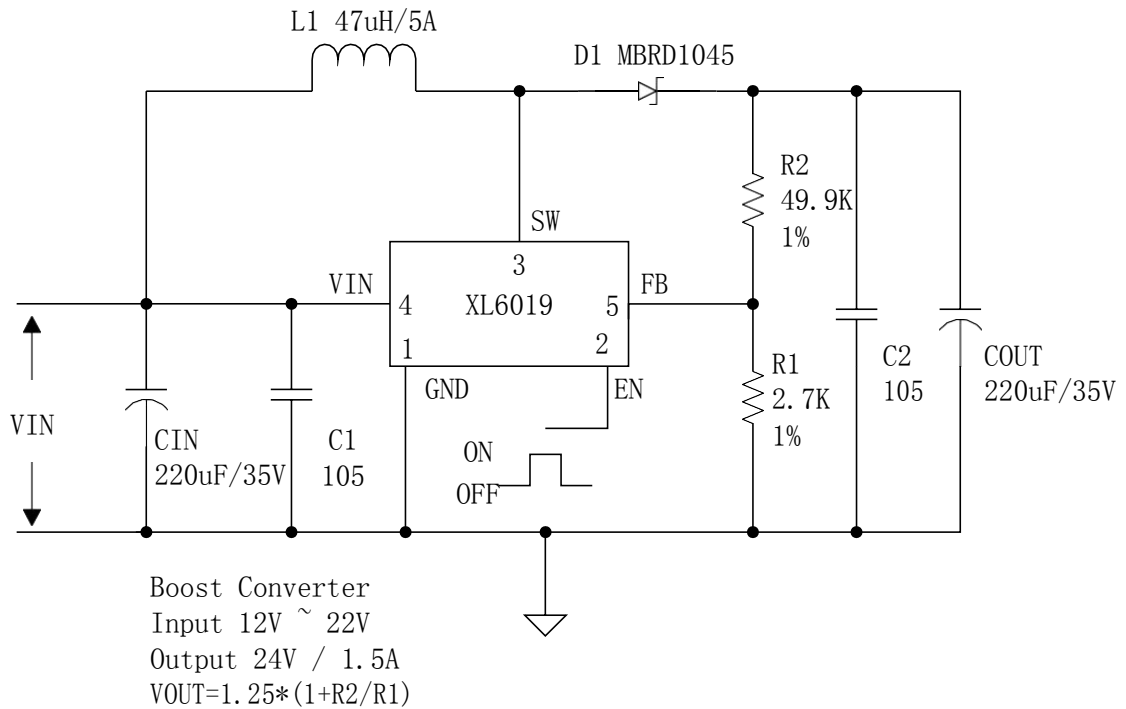

Figure3. Function Block Diagram of XL6019

Typical Application Circuit



180KHz 60V 5A Switching Current Boost / Buck-Boost / Inverting DC/DC Converter

Figure4. XL6019 Typical Application Circuit (Boost Converter)

180KHz 60V 5A Switching Current Boost / Buck-Boost / Inverting DC/DC Converter
Ordering Information

Order Information	Marking ID	Package Type	Packing Type Supplied As
XL6019E1	XL6019E1	TO263-5L	800 Units on Tape & Reel

XLSEMI Pb-free products, as designated with “E1” suffix in the par number, are RoHS compliant.

Absolute Maximum Ratings (Note1)

Parameter	Symbol	Value	Unit
Input Voltage	V _{in}	-0.3 to 45	V
Feedback Pin Voltage	V _{FB}	-0.3 to V _{in}	V
EN Pin Voltage	V _{EN}	-0.3 to V _{in}	V
Output Switch Pin Voltage	V _{Output}	-0.3 to 60	V
Power Dissipation	P _D	Internally limited	mW
Thermal Resistance (TO263-5L) (Junction to Ambient, No Heatsink, Free Air)	R _{JA}	30	°C/W
Maximum Junction Temperature	T _J	-40 to 150	°C
Operating Junction Temperature	T _J	-40 to 125	°C
Storage Temperature	T _{STG}	-65 to 150	°C
Lead Temperature (Soldering, 10 sec)	T _{LEAD}	260	°C
ESD (HBM)		>2000	V

Note1: Stresses greater than those listed under Maximum Ratings may cause permanent damage to the device. This is a stress rating only and functional operation of the device at these or any other conditions above those indicated in the operation is not implied. Exposure to absolute maximum rating conditions for extended periods may affect reliability.

180KHz 60V 5A Switching Current Boost / Buck-Boost / Inverting DC/DC Converter

XL6019 Electrical Characteristics

$T_a = 25^\circ\text{C}$; unless otherwise specified.

Symbol	Parameter	Test Condition	Min.	Typ.	Max.	Unit
<i>System parameters test circuit figure4</i>						
VFB	Feedback Voltage	$V_{in} = 12\text{V to } 20\text{V}, V_{out}=24\text{V}$ $I_{load}=0.1\text{A to } 1\text{A}$	1.213	1.25	1.287	V
η	Efficiency	$V_{in}=12\text{V}, V_{out}=24\text{V}$ $I_{out}=1\text{A}$	-	93	-	%

Electrical Characteristics (DC Parameters)

$V_{in} = 12\text{V}$, $GND=0\text{V}$, V_{in} & GND parallel connect a 100uf/50V capacitor; $I_{out}=0.5\text{A}$, $T_a = 25^\circ\text{C}$; the others floating unless otherwise specified.

Parameters	Symbol	Test Condition	Min.	Typ.	Max.	Unit
Input operation voltage	V_{in}		5		40	V
Shutdown Supply Current	I_{STBY}	$V_{EN}=0\text{V}$		70	100	μA
Quiescent Supply Current	I_q	$V_{EN}=2\text{V}$, $V_{FB}=V_{in}$		2.5	5	mA
Oscillator Frequency	F_{osc}		144	180	253	KHz
SW OVP	V_{SW}	$V_{FB}=0\text{V}$		60		V
Switch Current Limit	I_L	$V_{FB}=0\text{V}$		5		A
Output Power NMOS	R_{dson}	$V_{in}=12\text{V}$, $I_{SW}=5\text{A}$		110	120	mohm
EN Pin Threshold	V_{EN}	High (Regulator ON)		1.4		V
		Low (Regulator OFF)		0.8		V
EN Pin Input Leakage Current	I_H	$V_{EN}=2\text{V (ON)}$		3	10	μA
	I_L	$V_{EN}=0\text{V (OFF)}$		3	10	μA
Max. Duty Cycle	D_{MAX}	$V_{FB}=0\text{V}$		90		%

180KHz 60V 5A Switching Current Boost / Buck-Boost / Inverting DC/DC Converter

Typical System Application (Recommend output current safe work range)

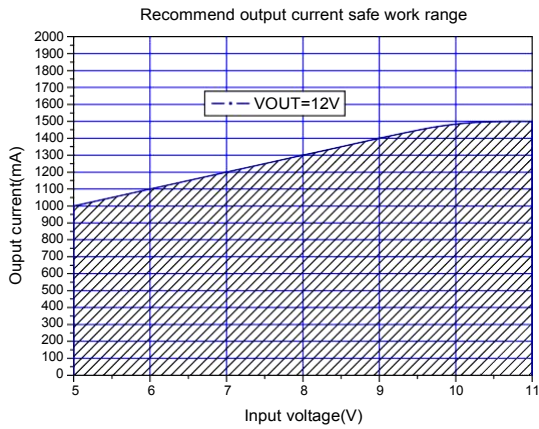

Figure5.Max output current (VOUT=12V)

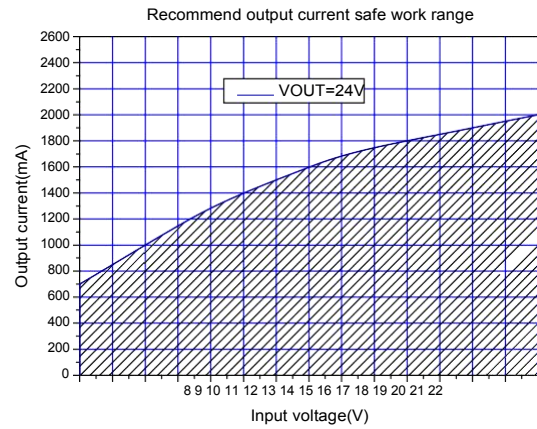

Figure6.Max output current (VOUT=24V)

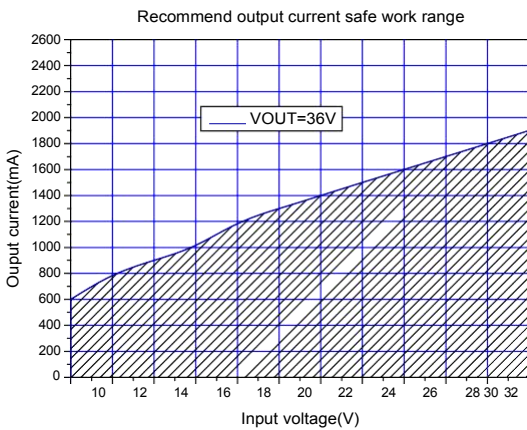

Figure7.Max output current (VOUT=36V)

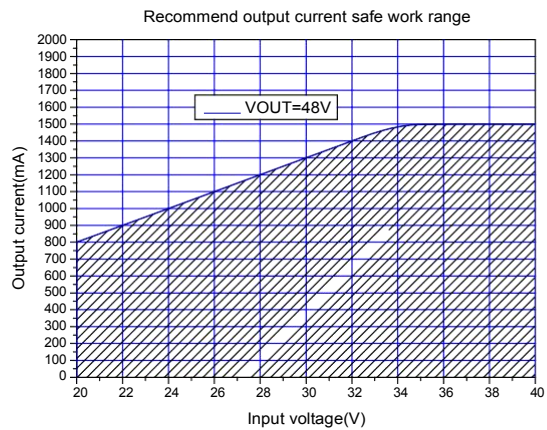

Figure8.Max output current(VOUT=48V)

180KHz 60V 5A Switching Current Boost / Buck-Boost / Inverting DC/DC Converter

Typical System Application(VIN=12V,VOUT=24V)

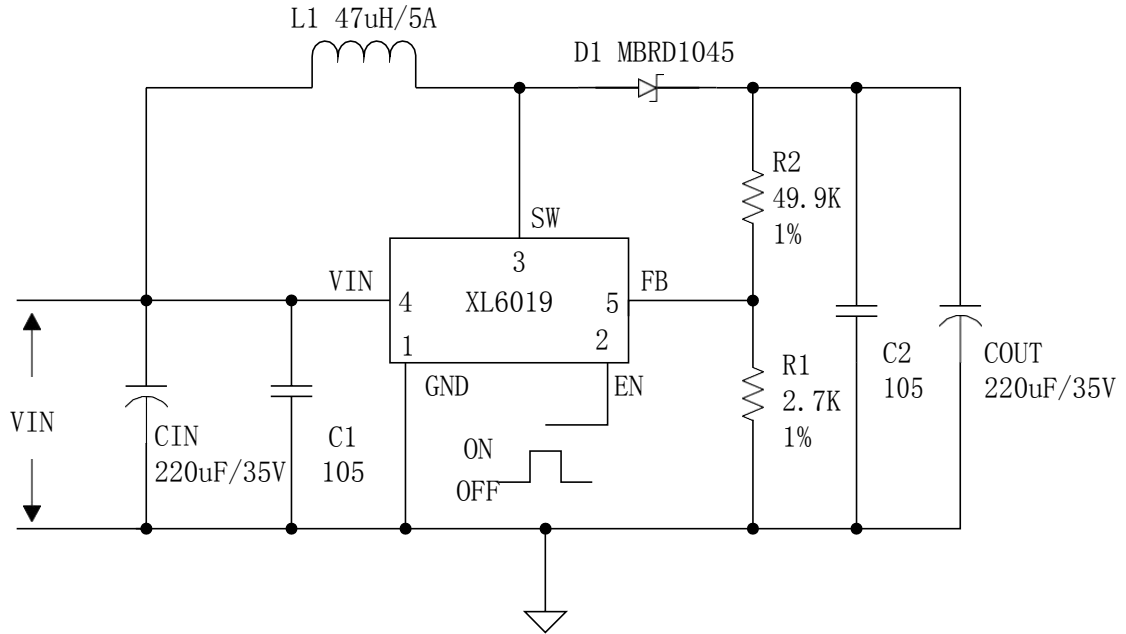

Figure9. XL6019 Typical System Application (VIN=12V,VOUT=24V)

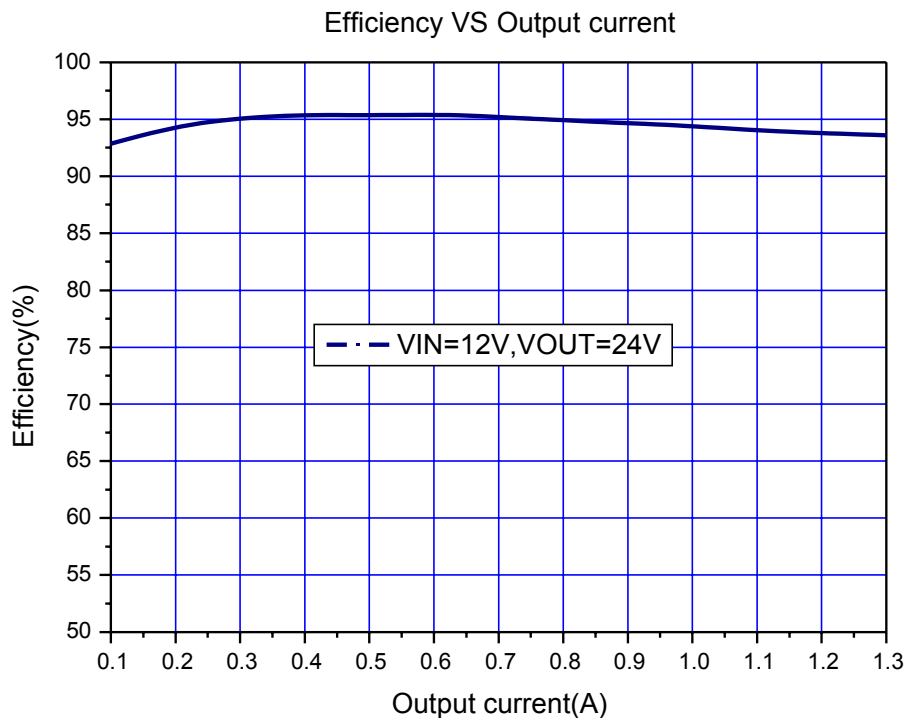

Figure10. XL6019 System Efficiency Curve (VIN=12V, VOUT=24V)

180KHz 60V 5A Switching Current Boost / Buck-Boost / Inverting DC/DC Converter

Typical System Application(VIN=5V,VOUT=12V)

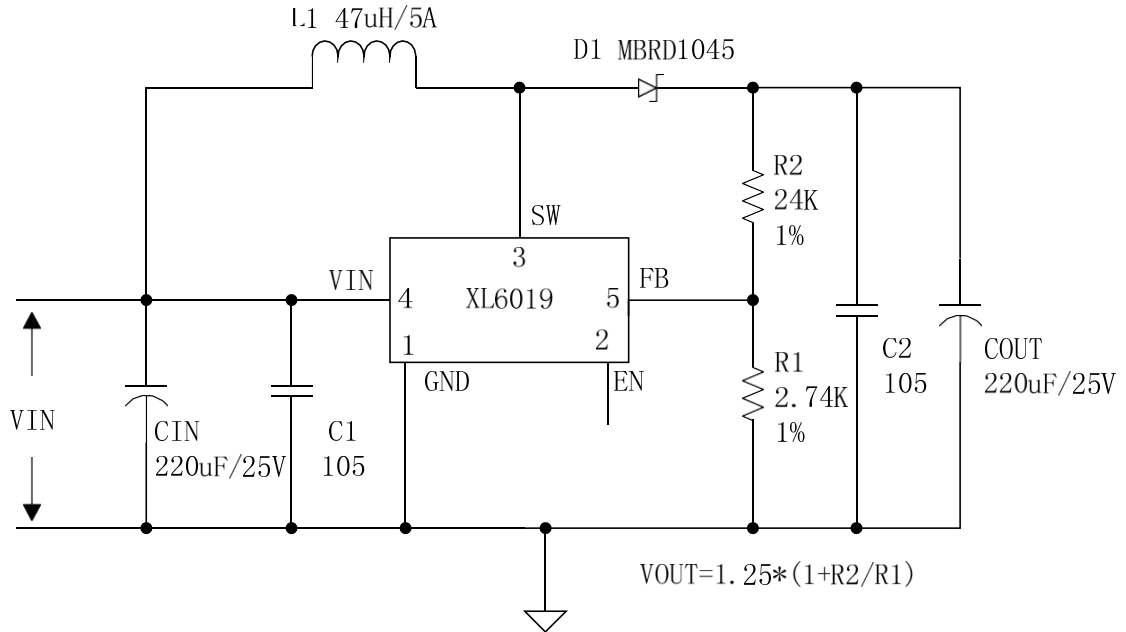

Figure11. XL6019 Typical System Application (VIN=5V,VOUT=12V)

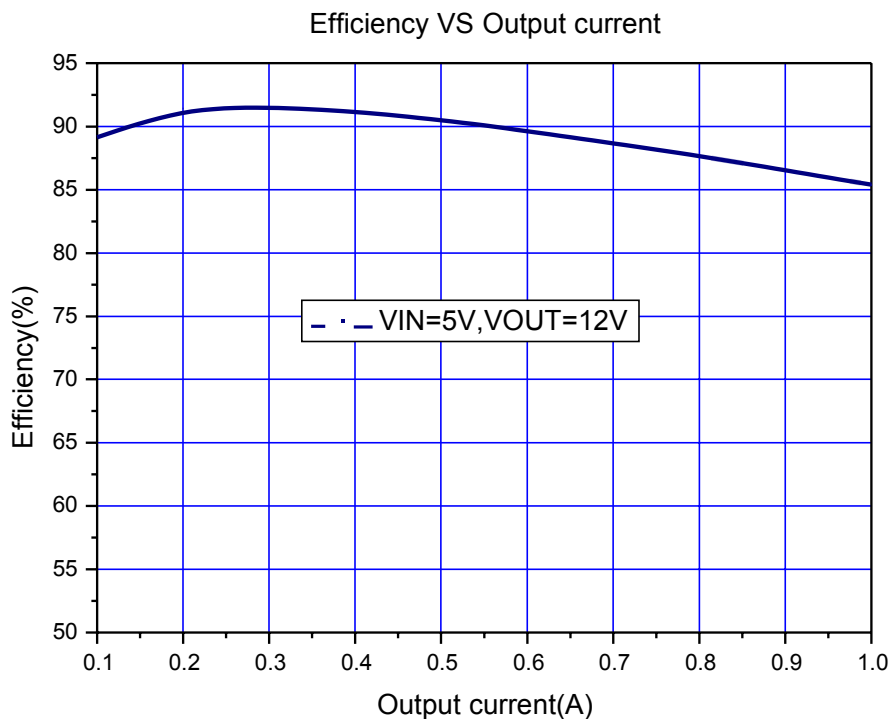

Figure12. XL6019 System Efficiency Curve (VIN=5V, VOUT=12V)

180KHz 60V 5A Switching Current Boost / Buck-Boost / Inverting DC/DC Converter

Typical System Application(VIN=10~32V,VOUT=36V)

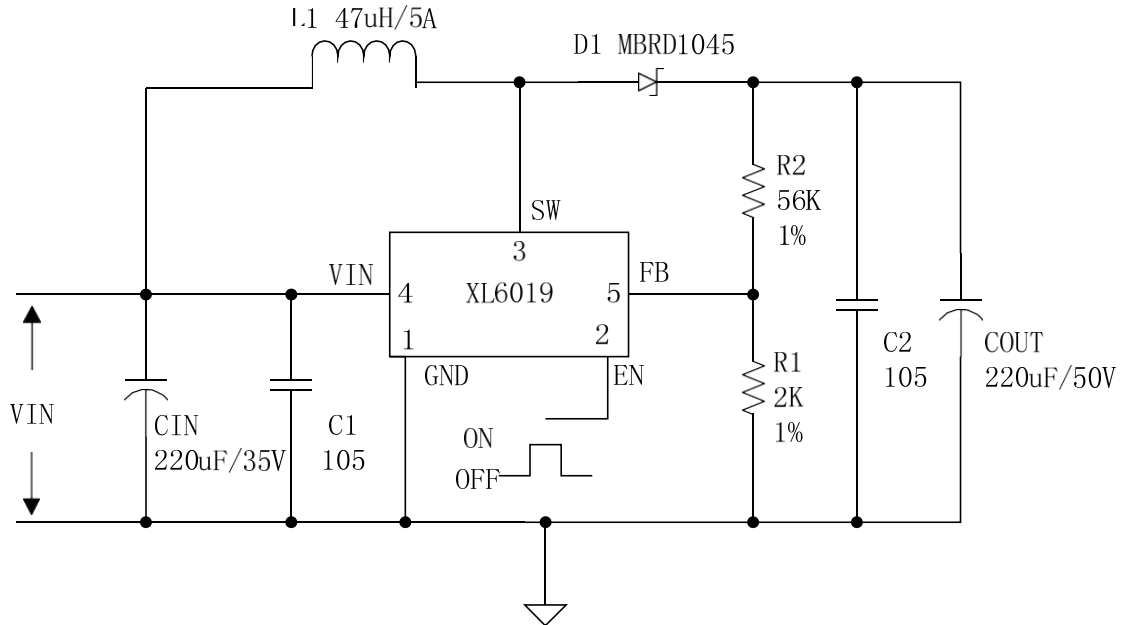

Figure13. XL6019 Typical System Application (VIN=10~32V,VOUT=36V)

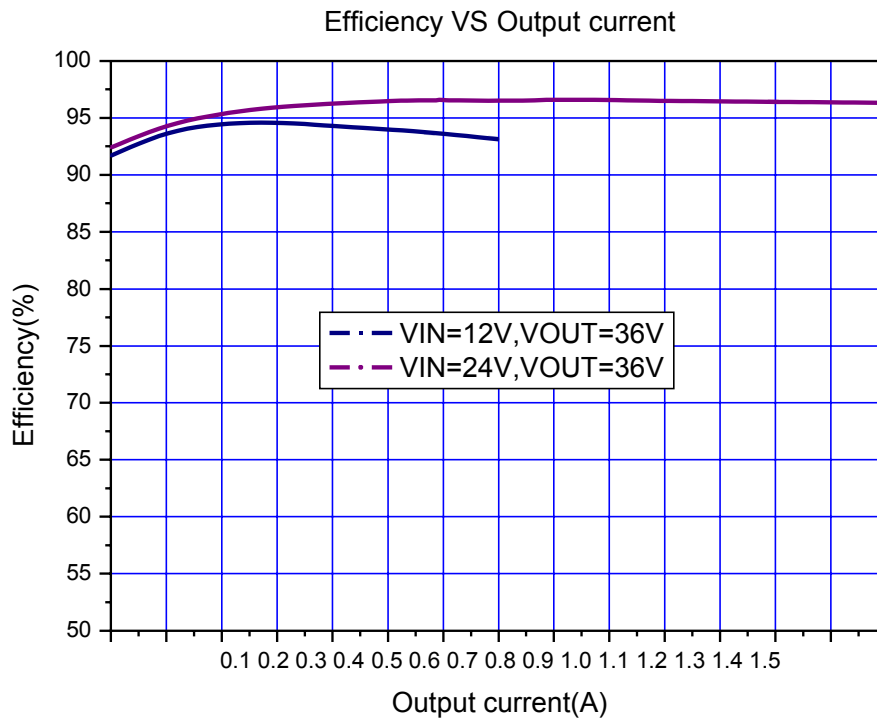

Figure14. XL6019 System Efficiency Curve (VIN=10~32V, VOUT=36V)

180KHz 60V 5A Switching Current Boost / Buck-Boost / Inverting DC/DC Converter

Typical System Application(VIN=20~40V,VOUT=48V)

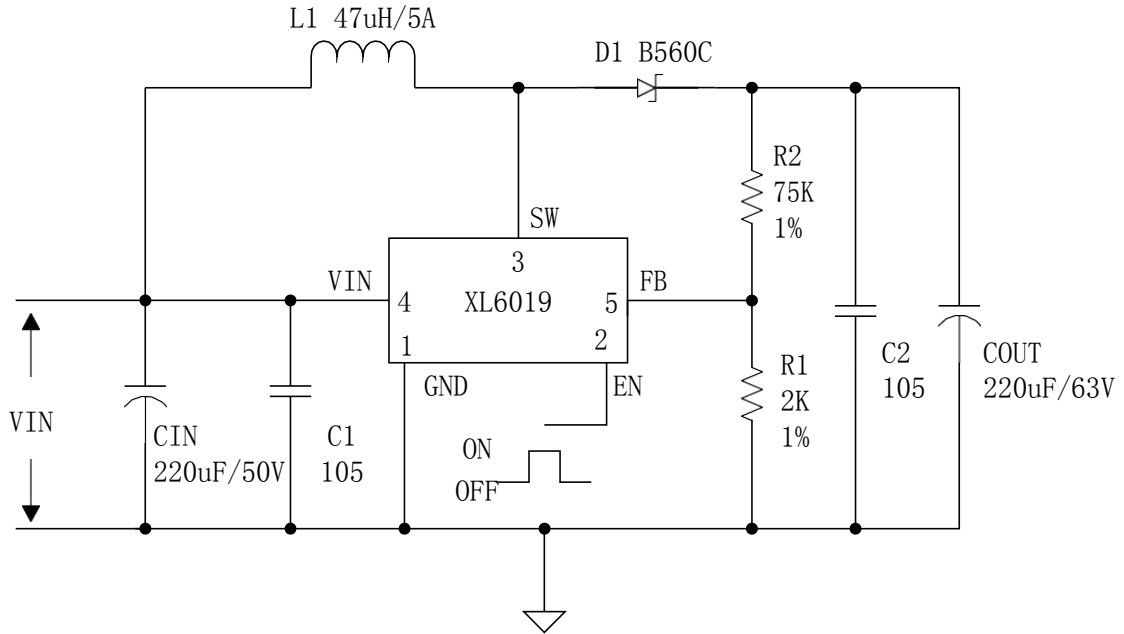

Figure15. XL6019 Typical System Application (VIN=20~40V,VOUT=48V)

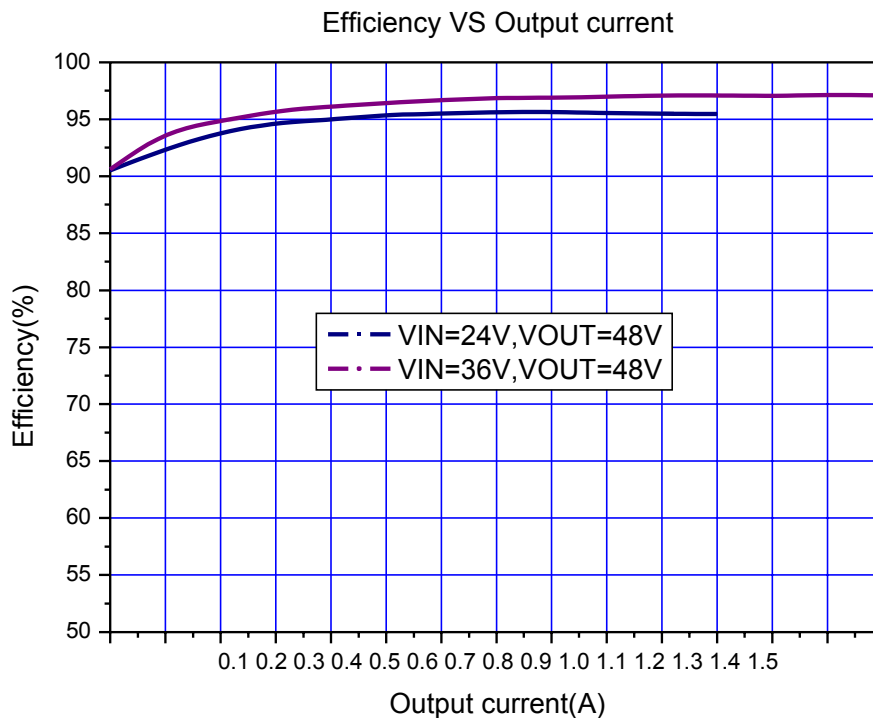

Figure16. XL6019 System Efficiency Curve (VIN=20~40V, VOUT=48V)

180KHz 60V 5A Switching Current Boost / Buck-Boost / Inverting DC/DC Converter

Typical System Application(VIN=10~30V,VOUT=12V)

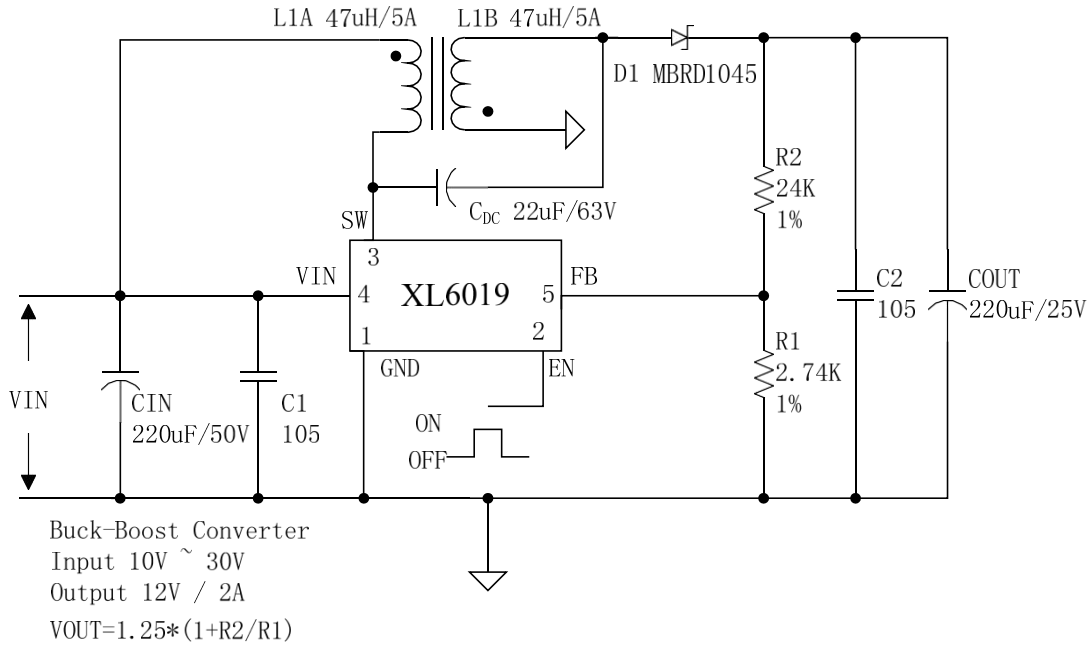
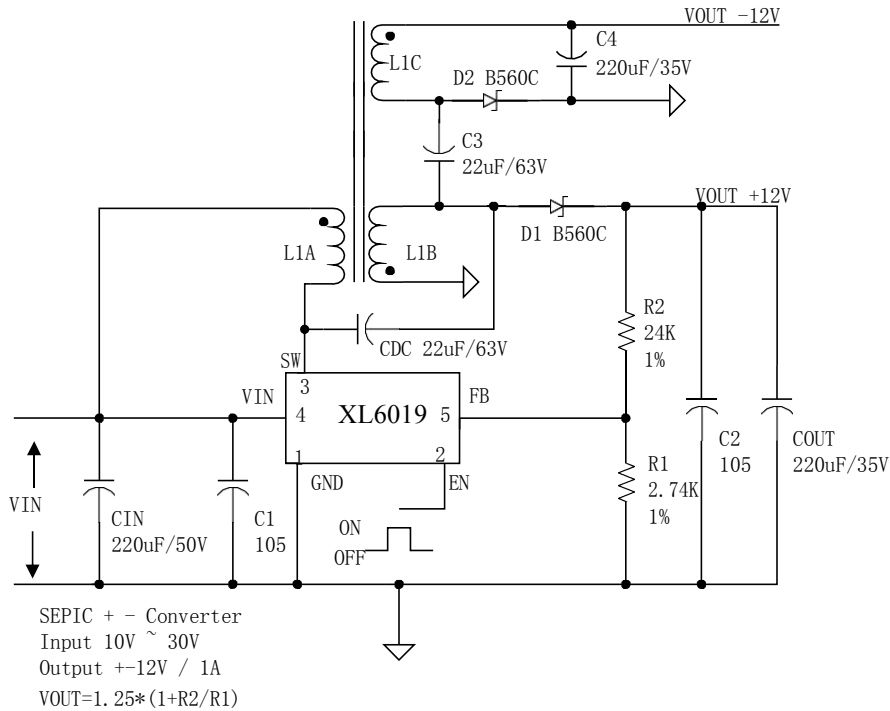

Figure17. XL6019 Typical System Application (VIN=10~30V,VOUT=12V)

Typical System Application(VIN=10~30V,VOUT=±12V)



180KHz 60V 5A Switching Current Boost / Buck-Boost / Inverting DC/DC Converter

Figure18. XL6019 Typical System Application ($V_{IN}=10\sim 30V, V_{OUT}=\pm 12V$)

180KHz 60V 5A Switching Current Boost / Buck-Boost / Inverting DC/DC Converter

Package Information

TO263-5L

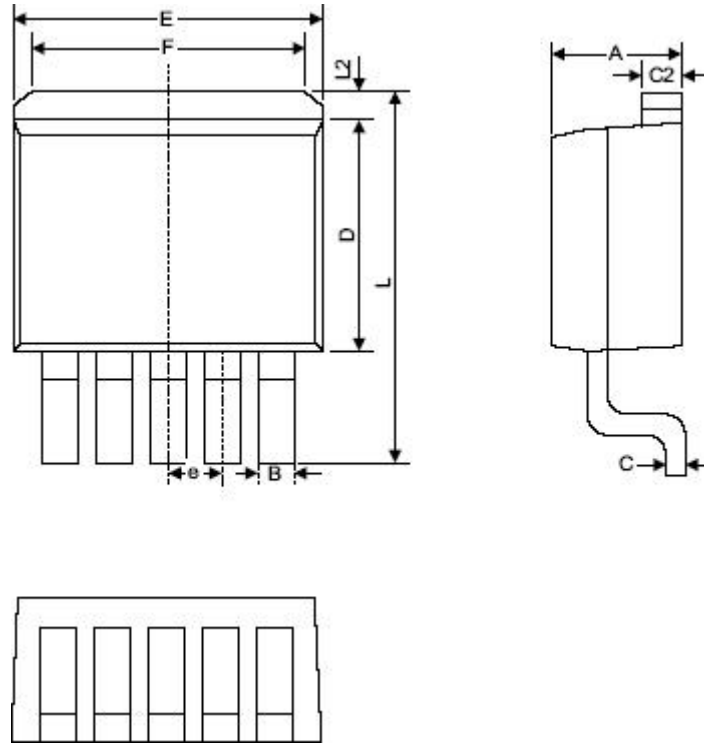

Symbol	Dimensions In Millimeters			Dimensions In Inches		
	Min.	Typ.	Max.	Min.	Typ.	Max.
A	4.440	4.570	4.650	0.175	0.180	0.183
B	0.710	0.870	0.970	0.028	0.034	0.038
C	0.360	0.380	0.640	0.014	0.015	0.025
C2	1.255	1.270	1.285	0.049	0.050	0.051
D	8.390	8.640	8.890	0.330	0.340	0.350
E	9.960	10.160	10.360	0.392	0.400	0.408
e	1.550	1.700	1.850	0.061	0.067	0.073
F	6.360	6.860	7.360	0.250	0.270	0.290
L	13.950	14.350	14.750	0.549	0.565	0.581
L2	1.120	1.270	1.420	0.044	0.050	0.056

180KHz 60V 5A Switching Current Boost / Buck-Boost / Inverting DC/DC Converter**Important Notice**

XLSEMI reserve the right to make modifications, enhancements, improvements, corrections or other changes without notice at any time. XLSEMI does not assume any liability arising out of the application or use of any product described herein; neither does it convey any license under its patent rights, nor the rights of others. XLSEMI assumes no liability for applications assistance or the design of Buyers' products. Buyers are responsible for their products and applications using XLSEMI components. To minimize the risks associated with Buyers' products and applications, Buyers should provide adequate design and operating safeguards. XLSEMI warrants performance of its products to the specifications applicable at the time of sale, in accordance with the warranty in XLSEMI's terms and conditions of sale of semiconductor products. Testing and other quality control techniques are used to the extent XLSEMI deems necessary to support this warranty. Except where mandated by applicable law, testing of all parameters of each component is not necessarily performed. For the latest product information, go to www.xlsemi.com.