

## Features

- Wide 8V to 40V Input Voltage Range
- Output Adjustable from 1.25V to 36V
- Maximum Duty Cycle 100%
- Minimum Drop Out 0.3V
- Fixed 180KHz Switching Frequency
- 8A Constant Output Current Capability
- Internal Optimize Power MOSFET
- High efficiency up to 96%
- Excellent line and load regulation
- Built in thermal shutdown function
- Built in current limit function
- Built in output short protection function
- Built in input over voltage protection
- Available in TO220-5L package

## Applications

- LCD Monitor and LCD TV
- Portable instrument power supply
- Telecom / Networking Equipment

## General Description

The XL4016 is a 180 KHz fixed frequency PWM buck (step-down) DC/DC converter, capable of driving a 8A load with high efficiency, low ripple and excellent line and load regulation. Requiring a minimum number of external components, the regulator is simple to use and include internal frequency compensation and a fixed-frequency oscillator.

The PWM control circuit is able to adjust the duty ratio linearly from 0 to 100%. An over current protection function is built inside. When short protection function happens, the operation frequency will be reduced from 180KHz to 48KHz. An internal compensation block is built in to minimize external component count.



Figure1. Package Type of XL4016

Pin Configurations

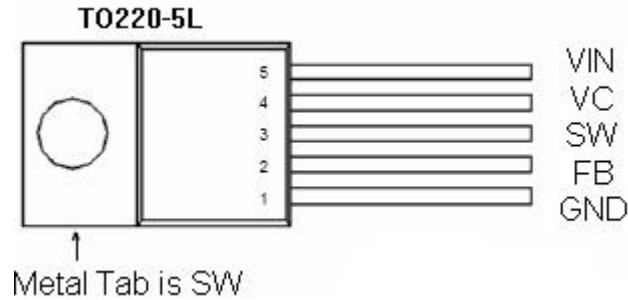

Figure2. Pin Configuration of XL4016 (Top View)

Table 1 Pin Description

Pin Number	Pin Name	Description
1	GND	Ground Pin. Care must be taken in layout. This pin should be placed outside of the Schottky Diode to output capacitor ground path to prevent switching current spikes from inducing voltage noise into XL4016.
2	FB	Feedback Pin (FB). Through an external resistor divider network, FB senses the output voltage and regulates it. The feedback threshold voltage is 1.25V.
3	SW	Power Switch Output Pin (SW). SW is the switch node that supplies power to the output.
4	VC	Internal Voltage Regulator Bypass Capacity. In typical system application, The VC pin connect a 1uf capacity to VIN.
5	VIN	Supply Voltage Input Pin. XL4016 operates from a 8V to 40V DC voltage. Bypass Vin to GND with a suitably large capacitor to eliminate noise on the input.

Function Block

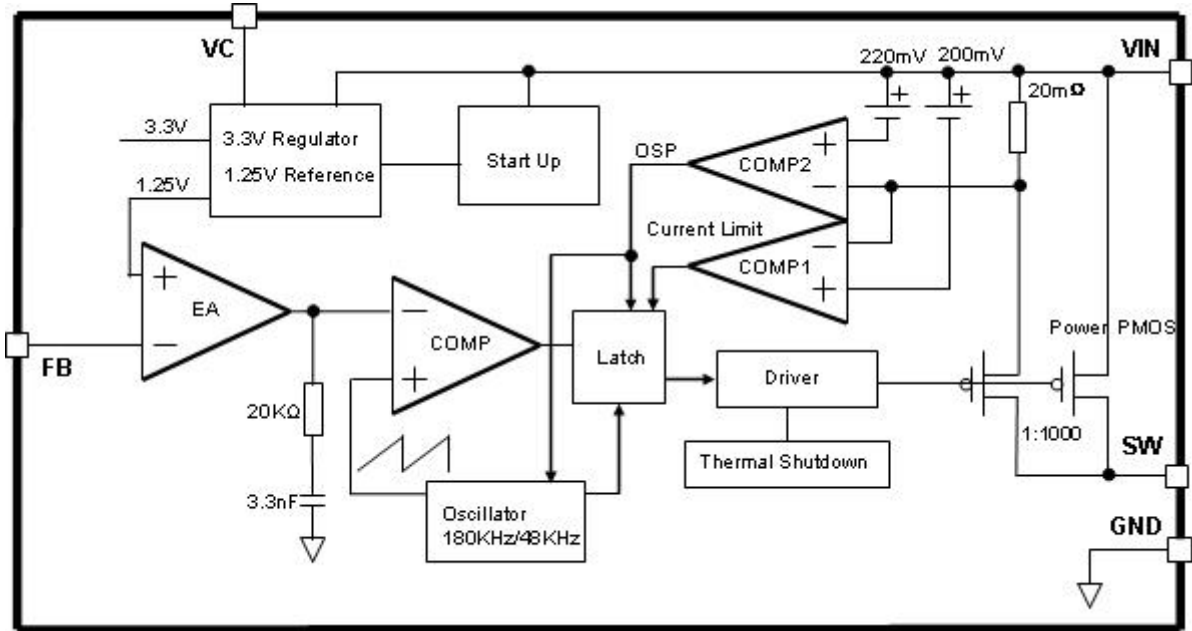

Figure3. Function Block Diagram of XL4016

Typical Application Circuit

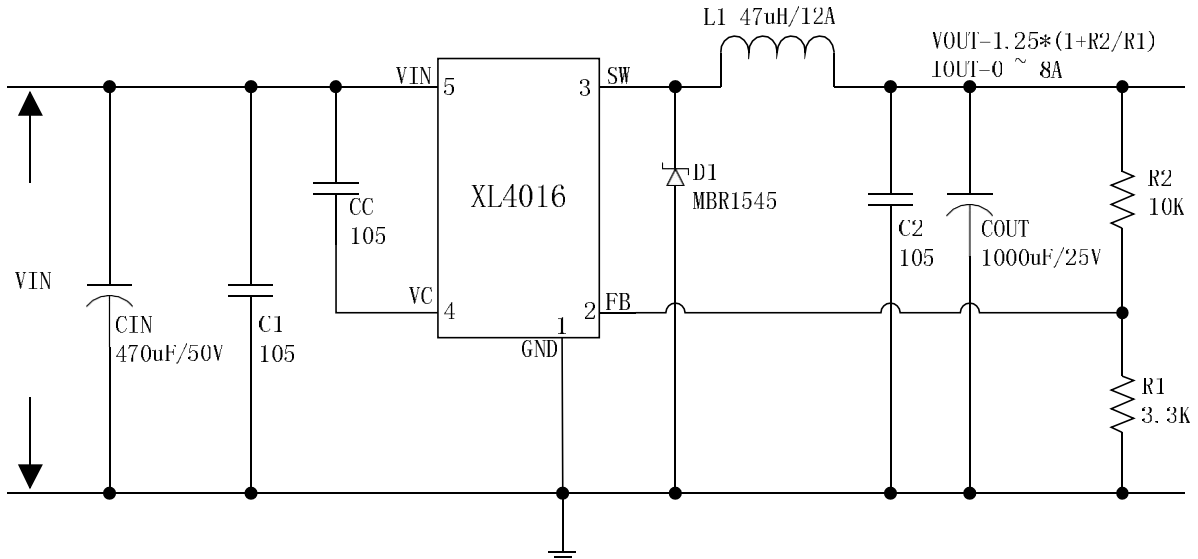

Figure4. XL4016 Typical Application Circuit (VIN=8V~40V, VOUT=5V/8A)

**8A 180KHz 40V Buck DC to DC Converter**

**XL4016**

**Ordering Information**

Order Information	Marking ID	Package Type	Packing Type Supplied As
XL4016E1	XL4016E1	TO220-5L	Tube

XLSEMI Pb-free products, as designated with “E1” suffix in the par number, are RoHS compliant.

**Absolute Maximum Ratings ( Note1 )**

Parameter	Symbol	Value	Unit
Input Voltage	$V_{in}$	-0.3 to 45	V
Feedback Pin Voltage	$V_{FB}$	-0.3 to $V_{in}$	V
Output Switch Pin Voltage	$V_{Output}$	-0.3 to $V_{in}$	V
Power Dissipation	$P_D$	Internally limited	mW
Thermal Resistance (TO220-5L) (Junction to Ambient, No Heatsink, Free Air)	$R_{JA}$	30	°C/W
Operating Junction Temperature	$T_J$	-40 to 125	°C
Storage Temperature	$T_{STG}$	-65 to 150	°C
Lead Temperature (Soldering, 10 sec)	$T_{LEAD}$	260	°C
ESD (HBM)		>2000	V

**Note1:** Stresses greater than those listed under Maximum Ratings may cause permanent damage to the device. This is a stress rating only and functional operation of the device at these or any other conditions above those indicated in the operation is not implied. Exposure to absolute maximum rating conditions for extended periods may affect reliability.

**8A 180KHz 40V Buck DC to DC Converter**

**XL4016**

**XL4016 Electrical Characteristics**

$T_a = 25^\circ\text{C}$ ; unless otherwise specified.

Symbol	Parameter	Test Condition	Min.	Typ.	Max.	Unit
<i>System parameters test circuit figure4</i>						
VFB	Feedback Voltage	$V_{in} = 8\text{V to } 40\text{V}, V_{out}=5\text{V}$ $I_{load}=0.5\text{A to } 8\text{A}$	1.225	1.25	1.275	V
Efficiency	$\eta$	$V_{in}=12\text{V}, V_{out}=5\text{V}$ $I_{out}=6\text{A}$	-	87	-	%
Efficiency	$\eta$	$V_{in}=24\text{V}, V_{out}=12\text{V}$ $I_{out}=6\text{A}$	-	93	-	%

**Electrical Characteristics (DC Parameters)**

$V_{in} = 12\text{V}$ ,  $GND=0\text{V}$ ,  $V_{in}$  &  $GND$  parallel connect a 470uf/50V capacitor;  $I_{out}=500\text{mA}$ ,  $T_a = 25^\circ\text{C}$ ; the others floating unless otherwise specified.

Parameters	Symbol	Test Condition	Min.	Typ.	Max.	Unit
Input operation voltage	$V_{in}$		8		40	V
Quiescent Supply Current	$I_q$	$V_{FB} = V_{in}$		2.1	5	mA
Oscillator Frequency	$F_{osc}$		144	180	216	KHz
Output Short Frequency	$F_{osp}$			48		KHz
Switch Current Limit	$I_L$	$V_{FB} = 0$		10		A
Max. Duty Cycle	$D_{MAX}$	$V_{FB}=0\text{V}$		100		%
Output Power PMOS	$R_{dson}$	$V_{FB}=0\text{V}, V_{in}=12\text{V},$ $I_{SW}=8\text{A}$		40	50	mohm
$V_{in}$ Over Voltage Protection	OVP			45		V

Typical System Application (VOUT=5V/8A)

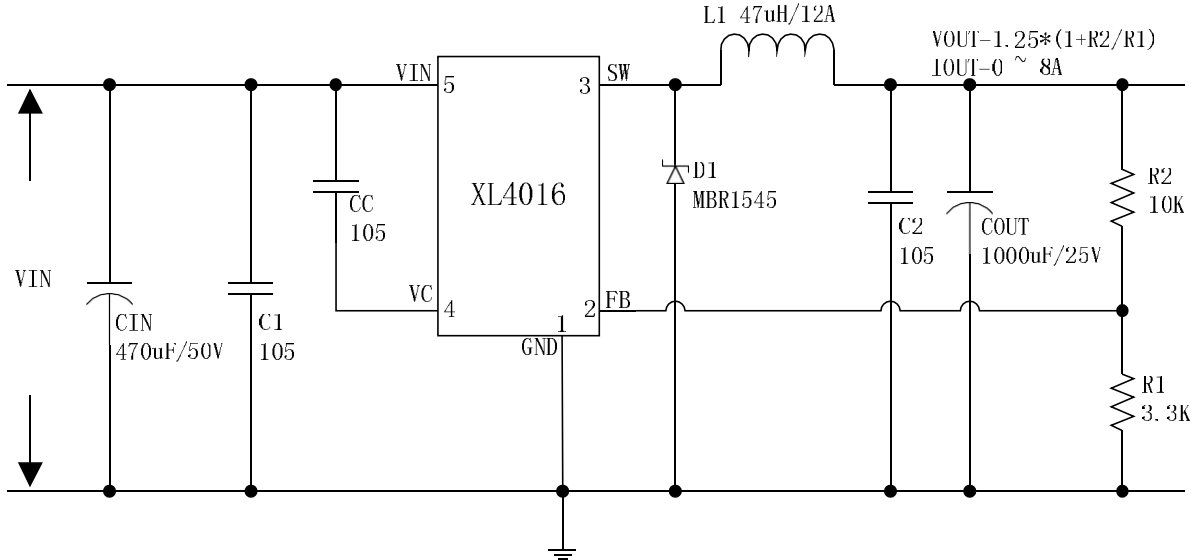

Figure5. XL4016 System Parameters Test Circuit (VIN=8V~40V, VOUT=5V/8A)

Efficiency VS Load current

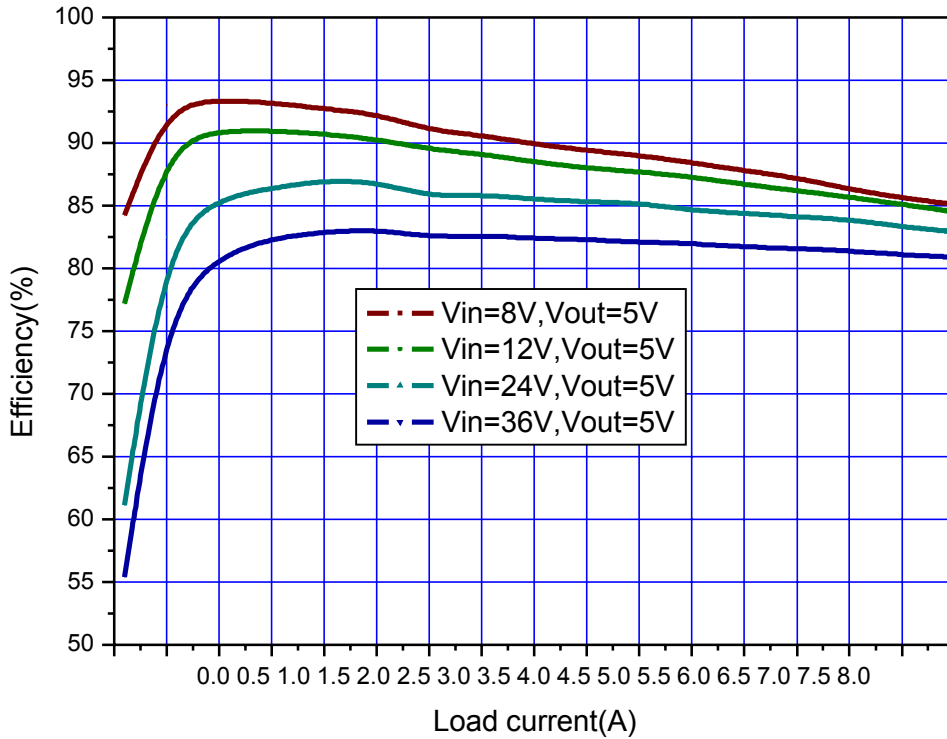

Figure6. XL4016 System Efficiency Curve

TLE:0755-88821663 88837366

深圳市福田区深南大道电子科技大厦C座23E www.yxd163.com

Typical System Application (VOUT=12V/6A)

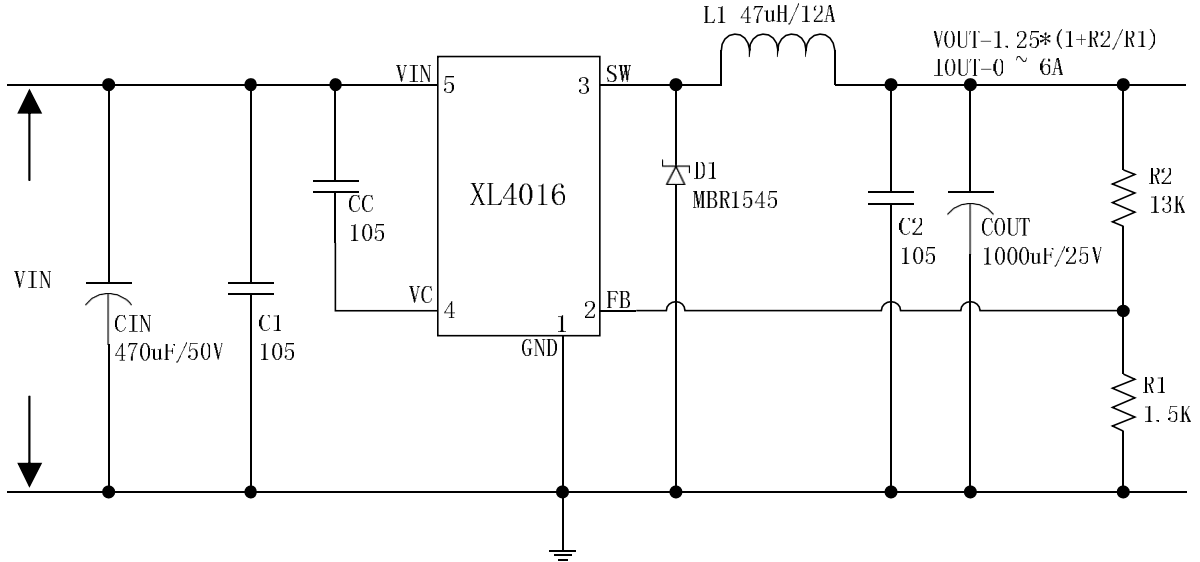

Figure7. XL4016 System Parameters Test Circuit (VIN=15V~40V, VOUT=12V/6A)

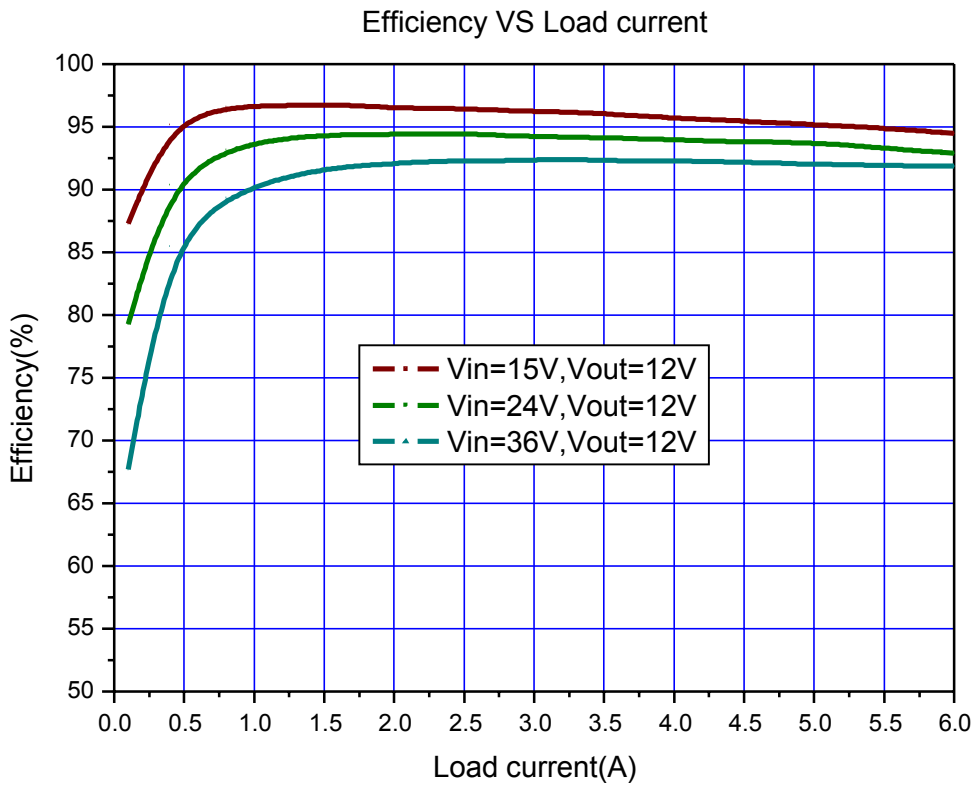

Figure8. XL4016 System Efficiency Curve

### Typical System Application (TTL shutdown function)

Logic level signals shutdown function can be used in typical system application with external components. When the TTL high voltage above 3.3V(referenced to ground, lower than VIN), the converter will shutdown, input current less than 5mA; when the TTL Low voltage below 0.8V(referenced to ground), the converter will turn on.

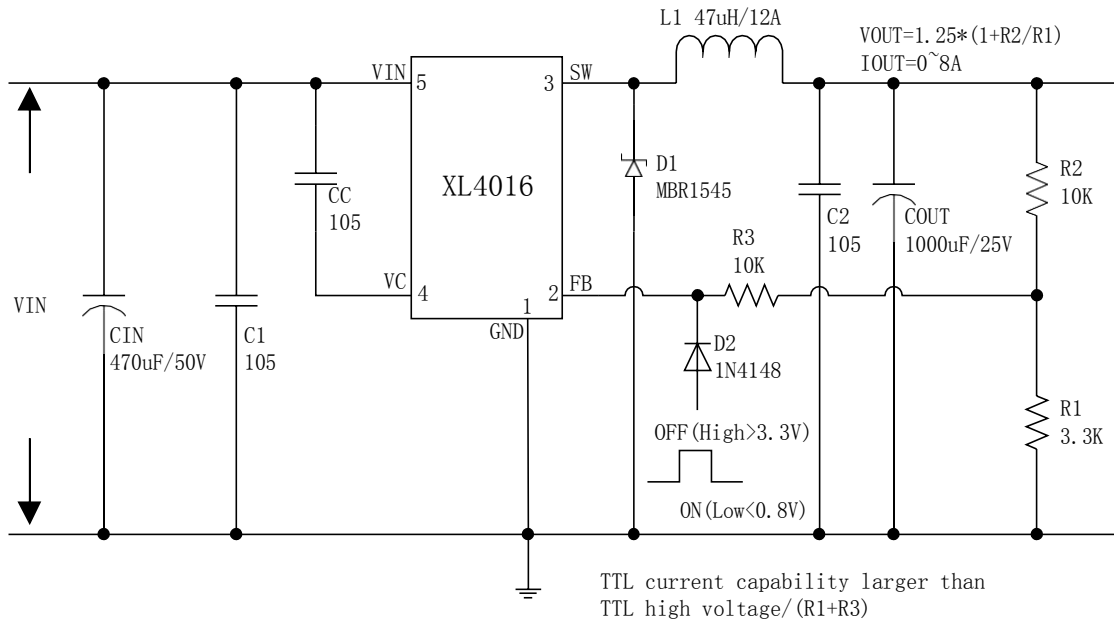

Figure9. XL4016 Typical Application Circuit



### Schottky Diode Selection Table

Current	Surface Mount	Through Hole	VR (The same as system maximum input voltage)				
			20V	30V	40V	50V	60V
1A		√	1N5817	1N5818	1N5819		
3A		√	1N5820	1N5821	1N5822		
		√	MBR320	MBR330	MBR340	MBR350	MBR360
	√		SK32	SK33	SK34	SK35	SK36
	√			30WQ03	30WQ04	30WQ05	
		√		31DQ03	31DQ04	31DQ05	
		√		SR302	SR303	SR304	SR305
5A		√	1N5823	1N5824	1N5825		
		√	SR502	SR503	SR504	SR505	SR506
		√	SB520	SB530	SB540	SB550	SB560
	√			50WQ03	50WQ04	50WQ05	
8A		√	SR820	SR830	SR840	SR850	SR860
16A		√	SR1620	SR1630	SR1640	SR1650	SR1660

Package Information

TO220-5L

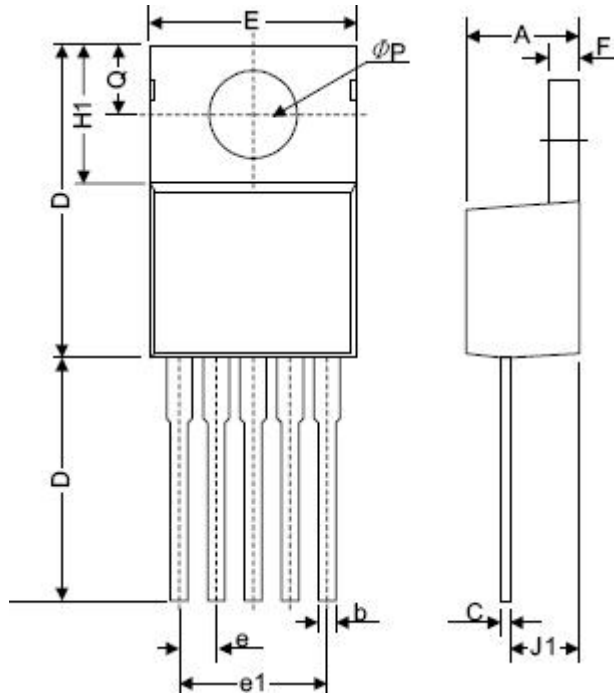

Symbol	Dimensions In Millimeters		Dimensions In Inches	
	Min.	Max.	Min.	Max.
A	4.06	4.83	0.160	0.190
b	0.76	1.02	0.030	0.040
C	0.36	0.64	0.014	0.025
D	14.22	15.49	0.560	0.610
E	9.78	10.54	0.385	0.415
e	1.57	1.85	0.062	0.073
e(1)	6.68	6.93	0.263	0.273
F	1.14	1.40	0.045	0.055
H(1)	5.46	6.86	0.215	0.270
J(1)	2.29	3.18	0.090	0.125
L	13.21	14.73	0.520	0.580
ϕP	3.68	3.94	0.145	0.155
Q	2.54	2.92	0.100	0.115

TLE:0755-88821663 88837366

深圳市福田区深南大道电子科技大厦C座23E www.yxd163.com