

3A 380KHz 23V Buck DC to DC Converter

XL1583

Features

- Wide 3.6V to 23V Input Voltage Range
- Output Adjustable from 1.222V to 21V
- Maximum Duty Cycle 100%
- Minimum Drop Out 0.6V
- Fixed 380KHz Switching Frequency
- 3A Constant Output Current Capability
- Internal Optimize Power MOSFET
- High efficiency
- Excellent line and load regulation
- TTL shutdown capability
- EN pin with hysteresis function
- Built in thermal shutdown function
- Built in current limit function
- Built in output short protection function
- Available in SOP8L package

Applications

- LCD Monitor and LCD TV
- Digital Photo Frame
- Set-up Box
- ADSL Modem
- Telecom / Networking Equipment

General Description

The XL1583 is a 380KHz fixed frequency PWM buck (step-down) DC/DC converter, capable of driving a 3A load with high efficiency, low ripple and excellent line and load regulation. Requiring a minimum number of external components, the regulator is simple to use and include internal frequency compensation and a fixed-frequency oscillator.

The PWM control circuit is able to adjust the duty ratio linearly from 0 to 100%. An enable function, an over current protection function is built inside. When short protection function happens, the operation frequency will be reduced from 380KHz to 80KHz. An internal compensation block is built in to minimize external component count.



Figure1. Package Type of XL1583

Pin Configurations

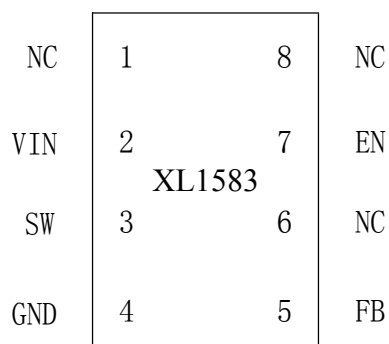

Figure2. Pin Configuration of XL1583 (Top View)

Table 1 Pin Description

Pin Number	Pin Name	Description
1,6,8	NC	No Connected.
2	VIN	Supply Voltage Input Pin. XL1583 operates from a 3.6V to 23V DC voltage. Bypass Vin to GND with a suitably large capacitor to eliminate noise on the input.
3	SW	Power Switch Output Pin (SW). Output is the switch node that supplies power to the output.
4	GND	Ground Pin. Care must be taken in layout. This pin should be placed outside of the Schottky Diode to output capacitor ground path to prevent switching current spikes from inducing voltage noise into XL1583.
5	FB	Feedback Pin (FB). Through an external resistor divider network, Feedback senses the output voltage and regulates it. The feedback threshold voltage is 1.222V.
7	EN	Enable Pin. Drive EN pin low to turn off the device, drive it high to turn it on. Floating is default high.

3A 380KHz 23V Buck DC to DC Converter

XL1583

Function Block

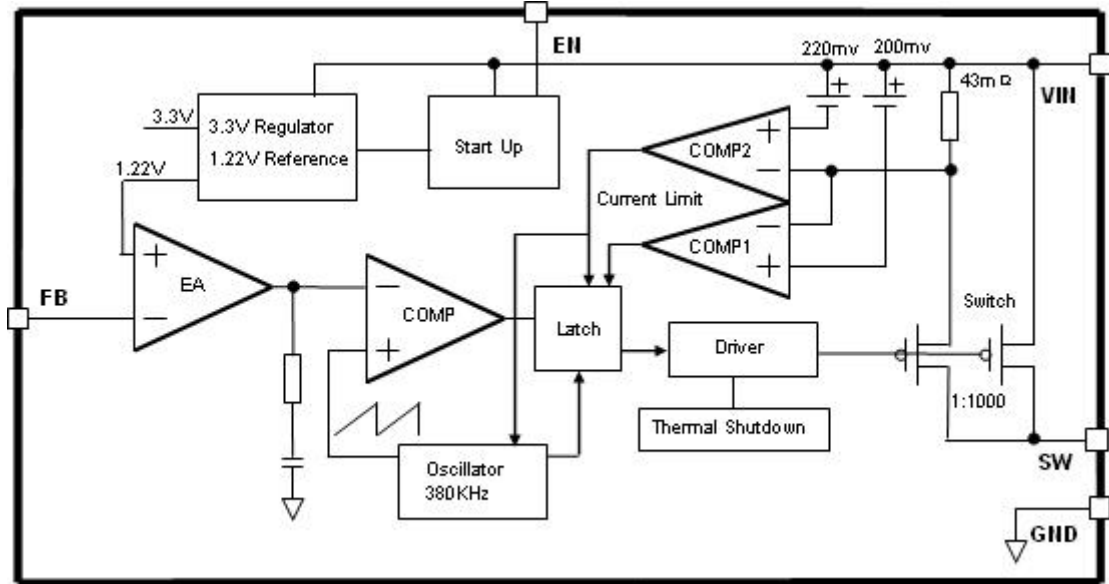

Figure3. Function Block Diagram of XL1583

Typical Application Circuit

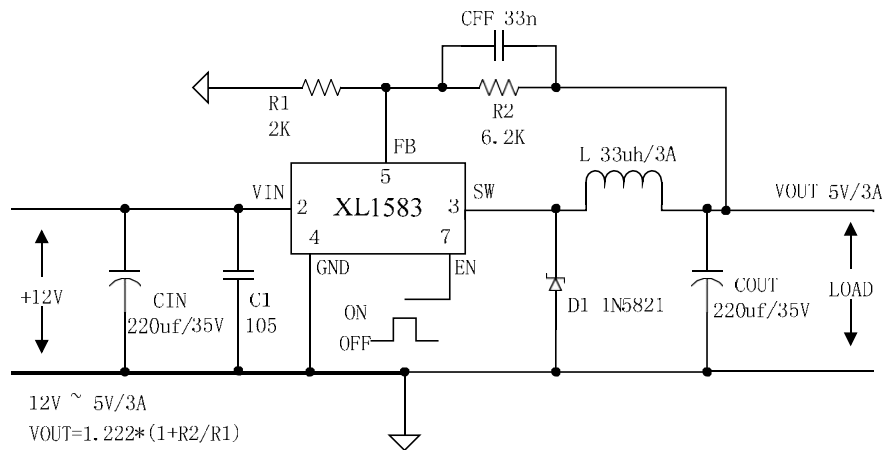

Figure4. XL1583 Typical Application Circuit 12V-5V/3A

3A 380KHz 23V Buck DC to DC Converter
XL1583
Ordering Information

Order Information	Marking ID	Package Type	Packing Type Supplied As
XL1583E1	XL1583E1	SOP8L	2500 Units on Tape & Reel

XLSEMI Pb-free products, as designated with “E1” suffix in the par number, are RoHS compliant.

Absolute Maximum Ratings (Note1)

Parameter	Symbol	Value	Unit
Input Voltage	V_{in}	-0.3 to 28	V
Feedback Pin Voltage	V_{FB}	-0.3 to V_{in}	V
EN Pin Voltage	V_{EN}	-0.3 to V_{in}	V
Output Switch Pin Voltage	V_{Output}	-0.3 to V_{in}	V
Power Dissipation	P_D	Internally limited	mW
Thermal Resistance (SOP8) (Junction to Ambient, No Heatsink, Free Air)	R_{JA}	100	°C/W
Operating Junction Temperature	T_J	-40 to 125	°C
Storage Temperature	T_{STG}	-65 to 150	°C
Lead Temperature (Soldering, 10 sec)	T_{LEAD}	260	°C
ESD (HBM)		2000	V

Note1: Stresses greater than those listed under Maximum Ratings may cause permanent damage to the device. This is a stress rating only and functional operation of the device at these or any other conditions above those indicated in the operation is not implied. Exposure to absolute maximum rating conditions for extended periods may affect reliability.

3A 380KHz 23V Buck DC to DC Converter

XL1583

XL1583 Electrical Characteristics

T_a = 25°C; unless otherwise specified.

Symbol	Parameter	Test Condition	Min.	Typ.	Max.	Unit
<i>System parameters test circuit figure4</i>						
VFB	Feedback Voltage	V _{in} = 7V to 25V, V _{out} =5V I _{load} =0.2A to 3A	1.186	1.222	1.258	V
Efficiency	η	V _{in} =12V, V _{out} =5V I _{out} =3A	-	89	-	%

Electrical Characteristics (DC Parameters)

V_{in} = 12V, GND=0V, V_{in} & GND parallel connect a 220uf/50V capacitor; I_{out}=500mA, T_a = 25°C; the others floating unless otherwise specified.

Parameters	Symbol	Test Condition	Min.	Typ.	Max.	Unit
Input operation voltage	V _{in}		3.6		23	V
Shutdown Supply Current	I _{STBY}	V _{EN} =0V		60	200	uA
Quiescent Supply Current	I _q	V _{EN} =2V, V _{FB} =V _{in}		3	5	mA
Oscillator Frequency	F _{osc}		323	380	437	Khz
Switch Current Limit	I _L	V _{FB} =0		4.7		A
EN Pin Threshold	V _{EN}	High (Regulator ON) Low (Regulator OFF)		1.4 0.8		V
EN Pin Input Leakage Current	I _H	V _{EN} =2V (ON)		1	15	uA
	I _L	V _{EN} =0V (OFF)		1	15	uA
Max. Duty Cycle	D _{MAX}	V _{FB} =0V		100		%

3A 380KHz 23V Buck DC to DC Converter

XL1583

Test Circuit and Layout guidelines

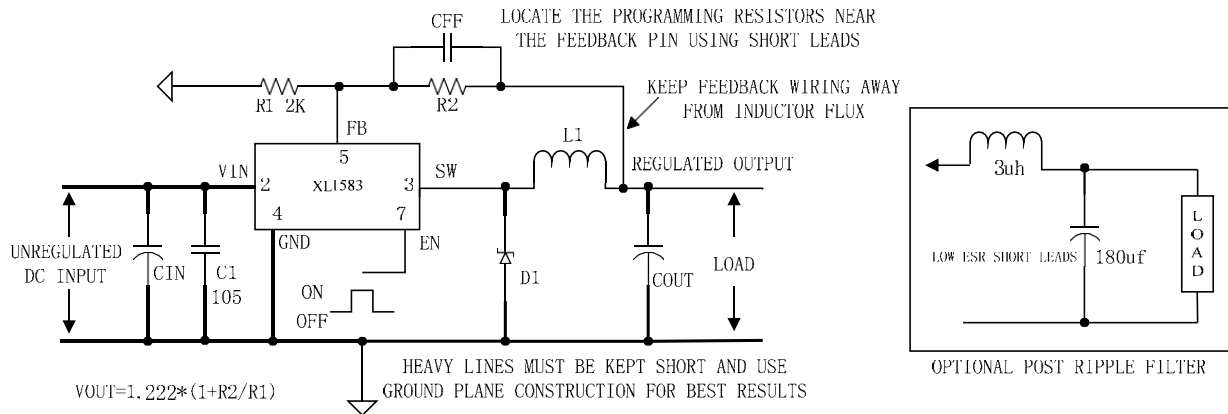

Figure5. Standard Test Circuits and Layout Guides

Select R1 to be approximately 2K, use a 1% resistor for best stability.

C1 and CFF are optional; in order to increase stability and reduce the input power line noise, CIN and C1 must be placed near to VIN and GND;

For output voltages greater than approximately 10V, an additional capacitor CFF is required. The compensation capacitor is typically between 100 pf and 33 nf, and is wired in parallel with the output voltage setting resistor, R2. It provides additional stability for high output voltage, low input-output voltages, and/or very low ESR output capacitors, such as solid tantalum capacitors. $CFF = 1 / (31 * 1000 * R2)$; This capacitor type can be ceramic, plastic, silver mica, etc. (Because of the unstable characteristics of ceramic capacitors made with Z5U material, they are not recommended.)

3A 380KHz 23V Buck DC to DC Converter

XL1583

Schottky Diode Selection Table

Current	Surface Mount	Through Hole	VR (The same as system maximum input voltage)				
			20V	30V	40V	50V	60V
1A		√	1N5817	1N5818	1N5819		
3A		√	1N5820	1N5821	1N5822		
		√	MBR320	MBR330	MBR340	MBR350	MBR360
	√		SK32	SK33	SK34	SK35	SK36
	√			30WQ03	30WQ04	30WQ05	
		√		31DQ03	31DQ04	31DQ05	
		√		SR302	SR303	SR304	SR305

3A 380KHz 23V Buck DC to DC Converter

XL1583

Typical System Application for 12V ~ 5V/3A Version

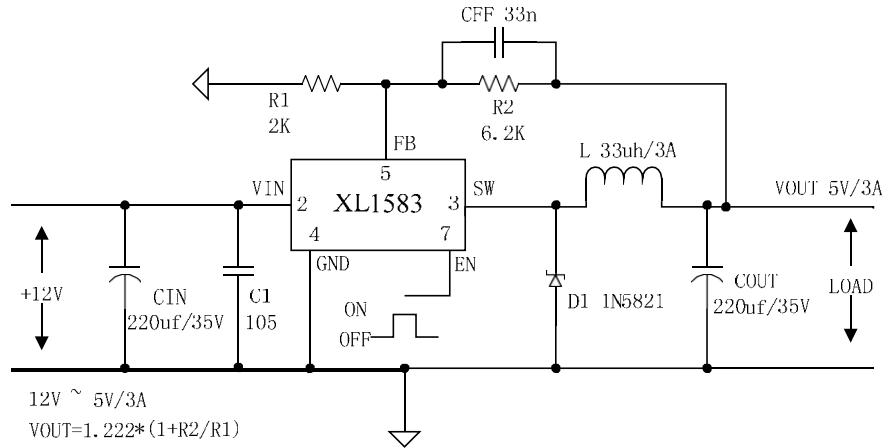

Figure6. XL1583 System Parameters Test Circuit (12V ~ 5V/3A)

Typical System Application for 12V ~ 3.3V/3A

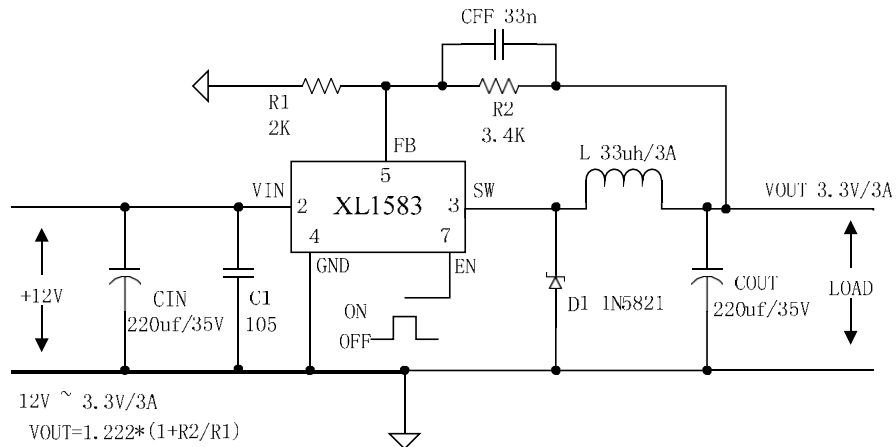

Figure7. XL1583 System Parameters Test Circuit (12V ~ 3.3V/3A)

Package Information

SOP8 Package Mechanical Dimensions

