

## Features

- Wide 3.6V to 18V Input Voltage Range
- Output Adjustable from 1.222V to 16V
- Maximum Duty Cycle 100%
- Minimum Drop Out 0.6V
- Fixed 380KHz Switching Frequency
- 2A Constant Output Current Capability
- Internal Optimize Power MOSFET
- High efficiency
- Excellent line and load regulation
- TTL shutdown capability
- EN pin with hysteresis function
- Built in thermal shutdown function
- Built in current limit function
- Built in output short protection function
- Available in SOP8L package

## Applications

- LCD Monitor and LCD TV
- Digital Photo Frame
- Set-up Box
- ADSL Modem
- Telecom / Networking Equipment

## General Description

The XL1410 is a 380KHz fixed frequency PWM buck (step-down) DC/DC converter, capable of driving a 2A load with high efficiency, low ripple and excellent line and load regulation. Requiring a minimum number of external components, the regulator is simple to use and include internal frequency compensation and a fixed-frequency oscillator.

The PWM control circuit is able to adjust the duty ratio linearly from 0 to 100%. An enable function, an over current protection function is built inside. When short protection function happens, the operation frequency will be reduced from 380KHz to 80KHz. An internal compensation block is built in to minimize external component count.



Figure1. Package Type of XL1410

**2A380KHz 18VBuckDC to DC Converter**

**XL1410**

**Pin Configurations**

NC	1	8	NC
VIN	2	7	EN
XL1410			
SW	3	6	NC
GND	4	5	FB

Figure2. Pin Configuration of XL1410 (Top View)

Pin Number	Pin Name	Description
1,6,8	NC	No Connected.
2	VIN	Supply Voltage Input Pin. XL1410 operates from a 3.6V to 18V DC voltage. Bypass Vin to GND with a suitably large capacitor to eliminate noise on the input.
3	SW	Power Switch Output Pin (SW). Output is the switch node that supplies power to the output.
4	GND	Ground Pin. Care must be taken in layout. This pin should be placed outside of the Schottky Diode to output capacitor ground path to prevent switching current spikes from inducing voltage noise into XL1410.
5	FB	Feedback Pin (FB). Through an external resistor divider network, Feedback senses the output voltage and regulates it. The feedback threshold voltage is 1.222V.
7	EN	Enable Pin. Drive EN pin low to turn off the device, drive it high to turn it on. Floating is default high.

**Function Block**

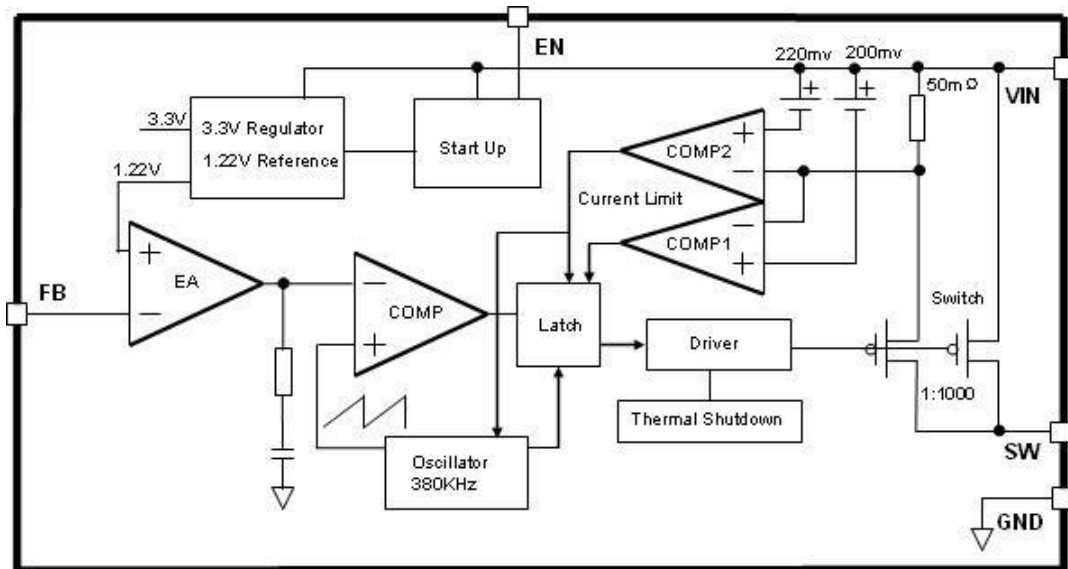

Figure3. Function Block Diagram of XL1410

**Typical Application Circuit**

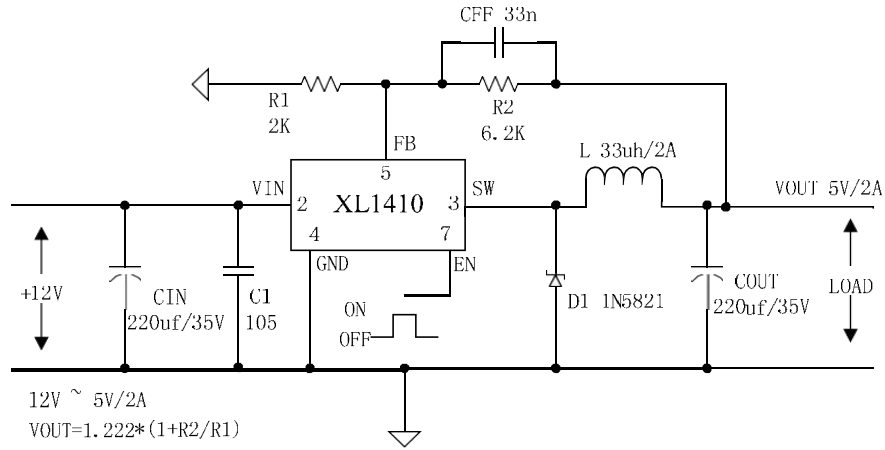
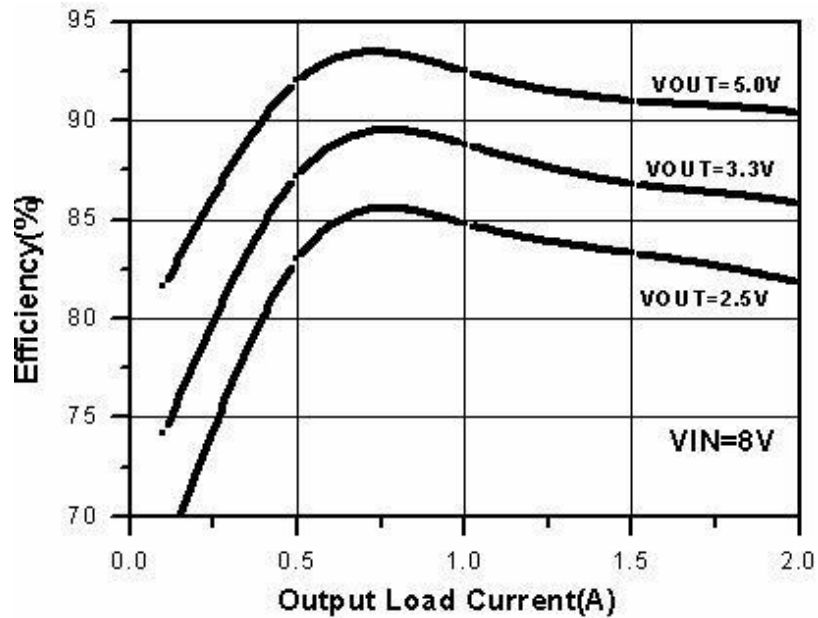

Figure4. XL1410 Typical Application Circuit

**System Efficiency Curve**



**2A380KHz 18VBuckDC to DC Converter**

**XL1410**

**Ordering Information**

Order Information	Marking ID	Package Type	Packing Type Supplied As
XL1410E1	XL1410E1	SOP8L	2500 Units on Tape & Reel

XLSEMI Pb-free products, as designated with “E1” suffix in the par number, are RoHS compliant.

**Absolute Maximum Ratings (Note1)**

Parameter	Symbol	Value	Unit
Input Voltage	$V_{in}$	-0.3 to 20	V
Feedback Pin Voltage	$V_{FB}$	-0.3 to $V_{in}$	V
EN Pin Voltage	$V_{EN}$	-0.3 to $V_{in}$	V
Output Switch Pin Voltage	$V_{Output}$	-0.3 to $V_{in}$	V
Power Dissipation	$P_D$	Internally limited	mW
Thermal Resistance (SOP8) (Junction to Ambient, No Heatsink, Free Air)	$R_{JA}$	100	°C/W
Operating Junction Temperature	$T_J$	-40 to 125	°C
Storage Temperature	$T_{STG}$	-65 to 150	°C
Lead Temperature (Soldering, 10 sec)	$T_{LEAD}$	260	°C
ESD (HBM)		2000	V

**Note1:** Stresses greater than those listed under Maximum Ratings may cause permanent damage to the device. This is a stress rating only and functional operation of the device at these or any other conditions above those indicated in the operation is not implied. Exposure to absolute maximum rating conditions for extended periods may affect reliability.

**2A380KHz 18VBuckDC to DC Converter**

**XL1410**

**XL1410 Electrical Characteristics**

$T_a = 25^\circ\text{C}$ ; unless otherwise specified.

Symbol	Parameter	Test Condition	Min.	Typ.	Max.	Unit
<i>System parameters test circuit figure4</i>						
VFB	Feedback Voltage	$V_{in} = 7\text{V to } 18\text{V}, V_{out}=5\text{V}$ $I_{load}=0.2\text{A to } 2\text{A}$	1.186	1.222	1.258	V
Efficiency	$\eta$	$V_{in}=12\text{V}, V_{out}=5\text{V}$ $I_{out}=2\text{A}$	-	89	-	%

**Electrical Characteristics (DC Parameters)**

$V_{in} = 12\text{V}$ ,  $GND=0\text{V}$ ,  $V_{in}$  &  $GND$  parallel connect a  $220\mu\text{f}/50\text{V}$  capacitor;  $I_{out}=500\text{mA}$ ,  $T_a = 25^\circ\text{C}$ ; the others floating unless otherwise specified.

Parameters	Symbol	Test Condition	Min.	Typ.	Max.	Unit
Input operation voltage	$V_{in}$		3.6		18	V
Shutdown Supply Current	$I_{STBY}$	$V_{EN}=0\text{V}$		60	200	$\mu\text{A}$
Quiescent Supply Current	$I_q$	$V_{EN}=2\text{V},$ $V_{FB}=V_{in}$		3	5	mA
Oscillator Frequency	$F_{osc}$		323	380	437	Khz
Switch Current Limit	$I_L$	$V_{FB}=0$		4		A
EN Pin Threshold	$V_{EN}$	High (Regulator ON) Low (Regulator OFF)		1.4 0.8		V
EN Pin Input Leakage Current	$I_H$	$V_{EN}=2\text{V (ON)}$		1	15	$\mu\text{A}$
	$I_L$	$V_{EN}=0\text{V (OFF)}$		1	15	$\mu\text{A}$
Max. Duty Cycle	$D_{MAX}$	$V_{FB}=0\text{V}$		100		%

### Test Circuit and Layout guidelines

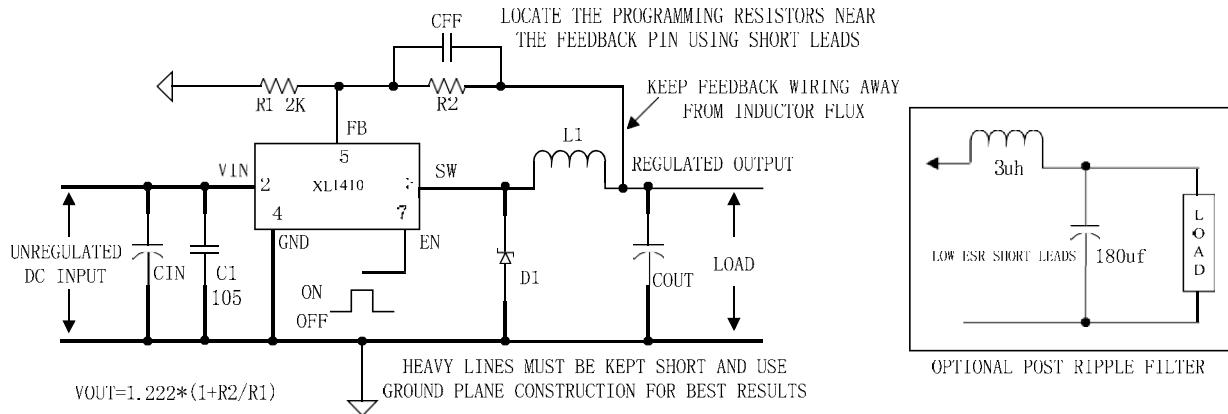

Figure5. Standard Test Circuits and Layout Guides

Select R1 to be approximately 2K, use a 1% resistor for best stability.

C1 and CFF are optional; in order to increase stability and reduce the input power line noise, CIN and C1 must be placed near to VIN and GND;

For output voltages greater than approximately 10V, an additional capacitor CFF is required. The compensation capacitor is typically between 100 pf and 33 nf, and is wired in parallel with the output voltage setting resistor, R2. It provides additional stability for high output voltage, low input-output voltages, and/or very low ESR output capacitors, such as solid tantalum capacitors.  $CFF = 1 / (31 * 1000 * R2)$ ; This capacitor type can be ceramic, plastic, silver mica, etc. (Because of the unstable characteristics of ceramic capacitors made with Z5U material, they are not recommended.)

**Schottky Diode Selection Table**

Current	Surface Mount	Through Hole	VR (The same as system maximum input voltage)				
			20V	30V	40V	50V	60V
1A		√	1N5817	1N5818	1N5819		
3A		√	1N5820	1N5821	1N5822		
		√	MBR320	MBR330	MBR340	MBR350	MBR360
	√		SK32	SK33	SK34	SK35	SK36
	√			30WQ03	30WQ04	30WQ05	
		√		31DQ03	31DQ04	31DQ05	
		√	SR302	SR303	SR304	SR305	SR306

**Typical System Application for 12V ~ 5V/2A Version**

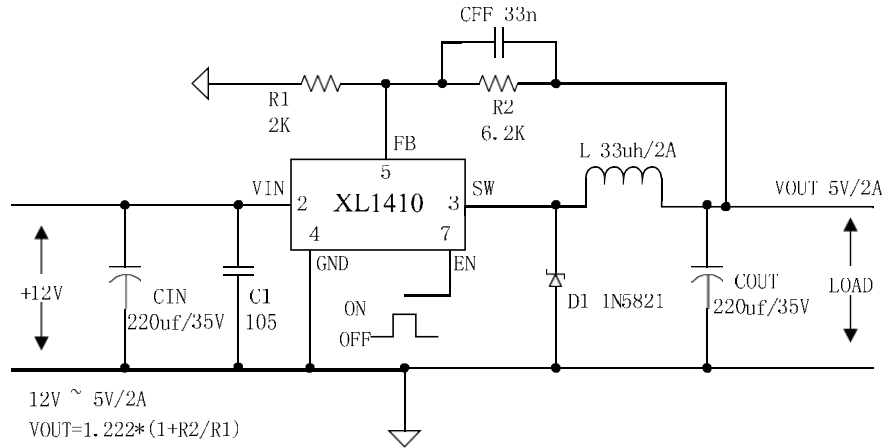

Figure6. XL1410 System Parameters Test Circuit (12V ~ 5V/2A)

**Typical System Application for 12V ~ 3.3V/2A**

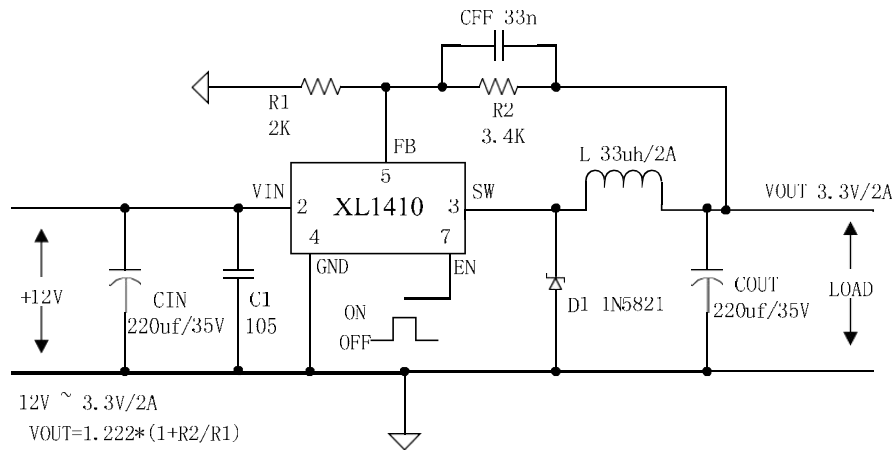

Figure7. XL1410 System Parameters Test Circuit (12V ~ 3.3V/2A)



**Package Information**

**SOP8 Package Mechanical Dimensions**

