



MX25L25673G

MX25L25673G

**3V, 256M-BIT [x 1/x 2/x 4]
CMOS MXSMIO[®] (SERIAL MULTI I/O)
FLASH MEMORY**

Key Features

- *Protocol Support - Single I/O, Dual I/O and Quad I/O*
- *Supports DTR (Double Transfer Rate) Mode*
- *Supports clock frequencies up to 133MHz*
- *Quad I/O mode is permanently enabled*

Contents

1. FEATURES	4
2. GENERAL DESCRIPTION	5
Table 1. Read performance Comparison.....	5
3. PIN CONFIGURATIONS	6
4. PIN DESCRIPTION	6
5. BLOCK DIAGRAM	7
6. DATA PROTECTION	8
Table 2. Protected Area Sizes.....	9
Table 3. 4K-bit Secured OTP Definition.....	10
7. Memory Organization	11
Table 4. Memory Organization.....	11
8. DEVICE OPERATION	12
8-1. 256Mb Address Protocol.....	15
8-2. Quad Peripheral Interface (QPI) Read Mode.....	16
9. COMMAND DESCRIPTION	17
Table 5. Command Set.....	17
9-1. Write Enable (WREN).....	22
9-2. Write Disable (WRDI).....	23
9-3. Factory Mode Enable (FMEN).....	24
9-4. Read Identification (RDID).....	25
9-5. Release from Deep Power-down (RDP), Read Electronic Signature (RES).....	26
9-6. Read Electronic Manufacturer ID & Device ID (REMS).....	28
9-7. QPI ID Read (QPIID).....	29
Table 6. ID Definitions.....	29
9-8. Read Status Register (RDSR).....	30
9-9. Read Configuration Register (RDCR).....	31
Table 7. Status Register.....	34
Table 8. Configuration Register.....	35
Table 9. Output Driver Strength Table.....	36
Table 10. Dummy Cycle and Frequency Table (MHz).....	36
9-10. Write Status Register (WRSR).....	37
Table 11. Protection Modes.....	38
9-11. Enter 4-byte mode (EN4B).....	40
9-12. Exit 4-byte mode (EX4B).....	40
9-13. Read Data Bytes (READ).....	41
9-14. Read Data Bytes at Higher Speed (FAST_READ).....	42
9-15. Dual Output Read Mode (DREAD).....	44
9-16. 2 x I/O Read Mode (2READ).....	45
9-17. Quad Read Mode (QREAD).....	46
9-18. 4 x I/O Read Mode (4READ).....	47
9-19. 4 x I/O Double Transfer Rate Read Mode (4DTRD).....	49
9-20. Preamble Bit.....	51
9-21. 4 Byte Address Command Set.....	55
9-22. Burst Read.....	58
9-23. Performance Enhance Mode.....	59
9-24. Sector Erase (SE).....	62
9-25. Block Erase (BE32K).....	63



9-26.	Block Erase (BE).....	64
9-27.	Chip Erase (CE).....	65
9-28.	Page Program (PP).....	66
9-29.	4 x I/O Page Program (4PP).....	68
9-30.	Deep Power-down (DP).....	69
9-31.	Write Security Register (WRSCUR).....	70
9-32.	Read Security Register (RDSCUR).....	71
9-33.	Enter Secured OTP (ENSO).....	72
9-34.	Exit Secured OTP (EXSO).....	72
	Table 12. Security Register Definition.....	73
9-35.	Write Protection Selection (WPSEL).....	74
9-36.	Advanced Sector Protection.....	76
	Table 13. Lock Register.....	77
	Table 14. SPB Register.....	78
	Table 15. DPB Register.....	80
9-37.	Program/Erase Suspend/Resume.....	82
9-38.	Erase Suspend.....	82
9-39.	Program Suspend.....	82
9-40.	Write-Resume.....	84
9-41.	No Operation (NOP).....	84
9-42.	Software Reset (Reset-Enable (RSTEN) and Reset (RST)).....	84
9-43.	Read SFDP Mode (RDSFDP).....	86
	Table 16. Signature and Parameter Identification Data Values.....	87
	Table 17. Parameter Table (0): JEDEC Flash Parameter Tables.....	89
	Table 18. Parameter Table (1): 4-Byte Instruction Tables.....	96
	Table 19. Parameter Table (2): Macronix Flash Parameter Tables.....	98
10.	RESET.....	100
	Table 20. Reset Timing-(Power On).....	100
	Table 21. Reset Timing-(Other Operation).....	100
11.	POWER-ON STATE.....	101
12.	ELECTRICAL SPECIFICATIONS.....	102
	Table 22. ABSOLUTE MAXIMUM RATINGS.....	102
	Table 23. CAPACITANCE TA = 25°C, f = 1.0 MHz.....	102
	Table 24. DC CHARACTERISTICS (Temperature = -40°C to 85°C, VCC = 2.7V - 3.6V).....	104
	Table 25. AC CHARACTERISTICS (Temperature = -40°C to 85°C, VCC = 2.7V - 3.6V).....	105
13.	OPERATING CONDITIONS.....	107
	Table 26. Power-Up/Down Voltage and Timing.....	109
13-1.	INITIAL DELIVERY STATE.....	109
14.	ERASE AND PROGRAMMING PERFORMANCE.....	110
15.	ERASE AND PROGRAMMING PERFORMANCE (Factory Mode).....	110
16.	DATA RETENTION.....	111
17.	LATCH-UP CHARACTERISTICS.....	111
18.	ORDERING INFORMATION.....	112
19.	PART NAME DESCRIPTION.....	113
20.	PACKAGE INFORMATION.....	114
20-1.	16-pin SOP (300mil).....	114
20-2.	8-pins SOP (200mil).....	115
20-3.	8-land WSON (6x5mm).....	116
20-4.	8-land WSON (8x6mm 3.4 x 4.3EP).....	117



21. REVISION HISTORY..... 118



MX25L25673G

3V 256M-BIT [x 1/x 2/x 4] CMOS MXSMIO® (SERIAL MULTII/O) FLASH MEMORY

1. FEATURES

GENERAL

- Supports Serial Peripheral Interface -- Mode 0 and Mode 3
- Single Power Supply Operation
 - 2.7 to 3.6 volt for read, erase, and program operations
- 268,435,456 x 1 bit structure
or 134,217,728 x 2 bits (two I/O mode) structure
or 67,108,864 x 4 bits (four I/O mode) structure
- Protocol Support
 - Single I/O, Dual I/O and Quad I/O
- Latch-up protected to 100mA from -1V to Vcc+1V
- Low Vcc write inhibit is from 1.5V to 2.5V
- Fast read for SPI mode
 - Supports clock frequencies up to 133MHz for all protocols
 - Supports Fast Read, 2READ, DREAD, 4READ, QREAD instructions
 - Supports DTR (Double Transfer Rate) Mode
 - Configurable dummy cycle number for fast read operation
- Default Quad I/O enable (QE bit=1), and can not be changed
- Quad Peripheral Interface (QPI) available
- Equal 4K byte Sectors, or Equal Blocks with 32K byte or 64K byte each
 - Any Block can be erased individually
- Programming :
 - 256byte page buffer
 - Quad Input/Output page program(4PP) to enhance program performance
- Typical 100,000 erase/program cycles
- 20 years data retention

SOFTWARE FEATURES

- Input Data Format
 - 1-byte Command code
- Advanced Security Features
 - Block lock protection
 - The BP0-BP3 and T/B status bits define the size of the area to be protected against program and erase instructions
 - Individual sector protection function (Solid Protect)
- Additional 4K bit secure OTP
 - Features unique identifier
 - Factory locked identifiable, and customer lockable
- Command Reset
- Program/Erase Suspend and Resume operation
- Electronic Identification
 - JEDEC 1-byte manufacturer ID and 2-byte device ID
 - RES command for 1-byte Device ID
 - REMS command for 1-byte manufacturer ID and 1-byte device ID
- Support Serial Flash Discoverable Parameters (SFDP) mode

HARDWARE FEATURES

- SCLK Input
 - Serial clock input
- SI/SIO0
 - Serial Data Input or Serial Data Input/Output for 2 x I/O read mode and 4 x I/O read mode
- SO/SIO1
 - Serial Data Output or Serial Data Input/Output for 2 x I/O read mode and 4 x I/O read mode
- SIO2
 - Serial data Input & Output for 4 x I/O read mode
- SIO3
 - Serial data Input & Output for 4 x I/O read mode
- RESET#
 - Hardware Reset pin
- PACKAGE
 - 16-pin SOP (300mil)
 - 8-pins SOP (200mil)
 - 8-land WSON (6x5mm)
 - 8-land WSON (8x6mm 3.4 x 4.3EP)
 - **All devices are RoHS Compliant and**



MX25L25673G



2. GENERAL DESCRIPTION

MX25L25673G is 256Mb bits Serial NOR Flash memory, which is configured as 33,554,432 x 8 internally. When it is in two or four I/O mode, the structure becomes 134,217,728 bits x 2 or 67,108,864 bits x 4.

MX25L25673G features a serial peripheral interface and software protocol allowing operation on a simple 3-wire bus while it is in single I/O mode. The three bus signals are a clock input (SCLK), a serial data input (SI), and a serial data output (SO). Serial access to the device is enabled by CS# input.

When it is in two I/O read mode, the SI pin and SO pin become SIO0 pin and SIO1 pin for address/dummy bits input and data output. When it is in four I/O read mode, the SI pin and SO pin become SIO0 pin and SIO1 pin for address/dummy bits input and data output.

The MX25L25673G MXSMIO® (Serial Multi I/O) provides sequential read operation on the whole chip.

After program/erase command is issued, auto program/erase algorithms which program/erase and verify the specified page or sector/block locations will be executed. Program command is executed on byte basis, or page (256 bytes) basis, or word basis. Erase command is executed on 4K-byte sector, 32K-byte block, or 64K-byte block, or whole chip basis.

To provide user with ease of interface, a status register is included to indicate the status of the chip. The status read command can be issued to detect completion status of a program or erase operation via WIP bit.

Advanced security features enhance the protection and security functions, please refer to the security features section for more details.

When the device is not in operation and CS# is high, it will remain in standby mode.

The MX25L25673G utilizes Macronix's proprietary memory cell, which reliably stores memory contents even after 100,000 program and erase cycles.

Table 1. Read performance Comparison

Numbers of Dummy Cycles	Fast Read (MHz)	Dual Output Fast Read (MHz)	Quad Output Fast Read (MHz)	Dual IO Fast Read (MHz)	Quad IO Fast Read (MHz)	Quad I/O DT Read (MHz)
4	-	-	-	80*	54	-
6	-	-	-	-	80*	54*
8	120*/133R	120*/133R	120*/133R	120/133R	84/104R	70/80R
10	-	-	-	-	120/133R	84/100R

Notes:

- 1. * mean default status.
- 2. R mean VCC range = 3.0V-3.6V.

3. PIN CONFIGURATIONS

8-PIN SOP (200mil)

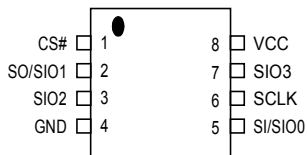

8-WSON (8x6mm, 6x5mm)

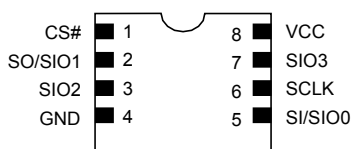

16-PIN SOP (300mil)

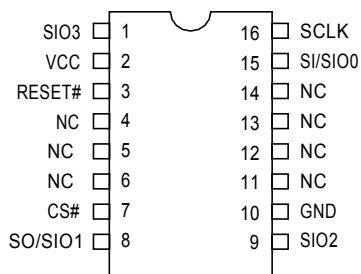

4. PIN DESCRIPTION

SYMBOL	DESCRIPTION
CS#	Chip Select
SI/SIO0	Serial Data Input (for 1 x I/O)/ Serial Data Input & Output (for 2xI/O or 4xI/O read mode)
SO/SIO1	Serial Data Output (for 1 x I/O)/ Serial Data Input & Output (for 2xI/O or 4xI/O read mode)
SCLK	Clock Input
SIO2	Serial Data Input & Output (for 4xI/O read mode)
SIO3	Serial Data Input & Output (for 4xI/O read mode)
RESET#*	Hardware Reset Pin Active low
VCC	+ 3V Power Supply
GND	Ground
NC	No Connection

Note*: The pin of RESET# will remain internal pull up function while this pin is not physically connected in system configuration. However, the internal pull up function will be disabled if the system has physical connection to RESET# pin.

5. BLOCK DIAGRAM

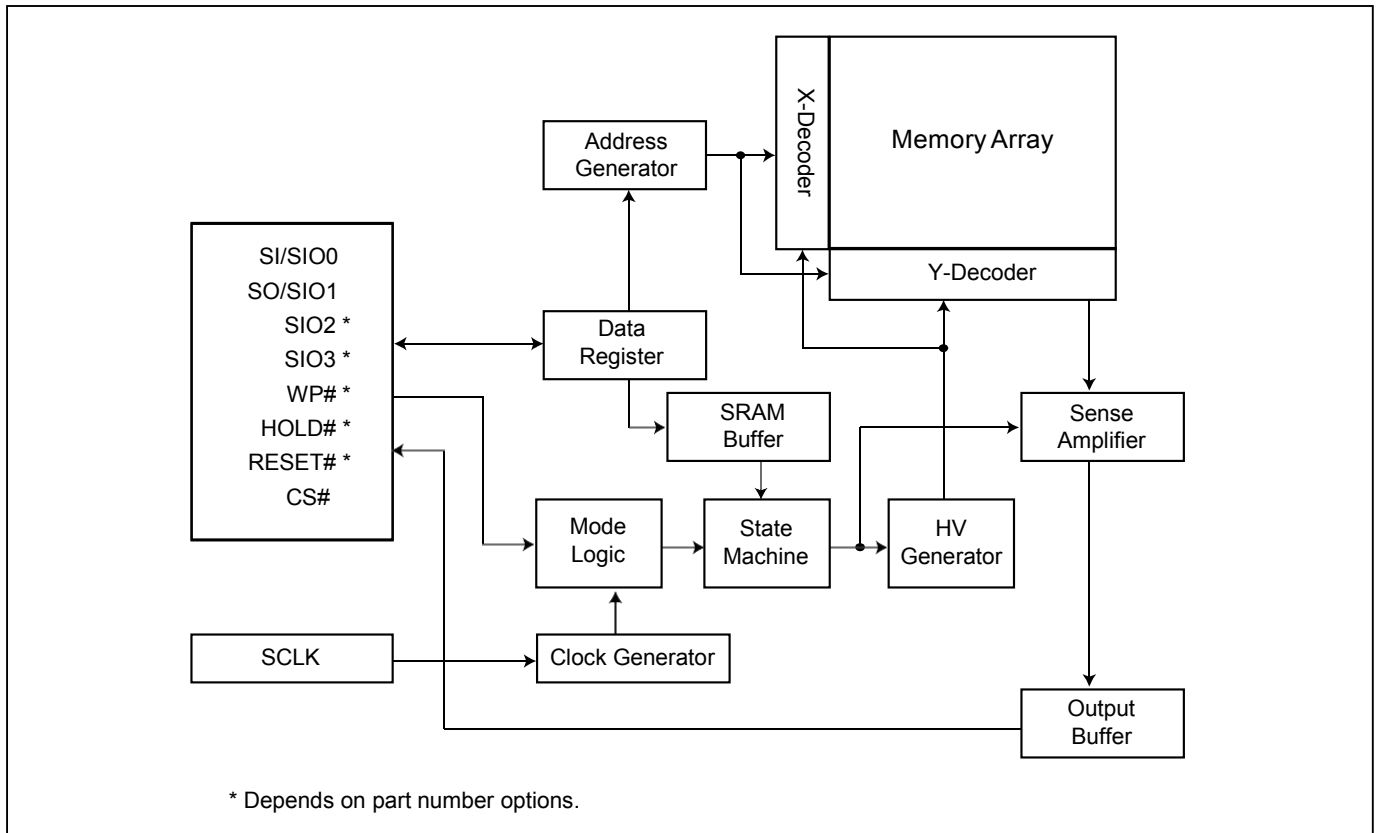



6. DATA PROTECTION

During power transition, there may be some false system level signals which result in inadvertent erasure or programming. The device is designed to protect itself from these accidental write cycles.

The state machine will be reset as standby mode automatically during power up. In addition, the control register architecture of the device constrains that the memory contents can only be changed after specific command sequences have completed successfully.

In the following, there are several features to protect the system from the accidental write cycles during VCC power-up and power-down or from system noise.

- Valid command length checking: The command length will be checked whether it is at byte base and completed on byte boundary.
- Write Enable (WREN) command: WREN command is required to set the Write Enable Latch bit (WEL) before other command to change data.
- Deep Power Down Mode: By entering deep power down mode, the flash device also is under protected from writing all commands except Release from deep power down mode command (RDP) and Read Electronic Signature command (RES), and softreset command.
- Advanced Security Features: there are some protection and security features which protect content from inadvertent write and hostile access.

I. Block lock protection

- The Software Protected Mode (SPM) use (BP3, BP2, BP1, BP0 and T/B) bits to allow part of memory to be protected as read only. The protected area definition is shown as [Table 2](#) Protected Area Sizes, the protected areas are more flexible which may protect various area by setting value of BP0-BP3 bits.

Table 2. Protected Area Sizes

Protected Area Sizes (T/B bit = 0)

Status bit				Protect Level
BP3	BP2	BP1	BP0	256Mb
0	0	0	0	0 (none)
0	0	0	1	1 (1 block, protected block 511th)
0	0	1	0	2 (2 blocks, protected block 510th~511th)
0	0	1	1	3 (4 blocks, protected block 508th~511th)
0	1	0	0	4 (8 blocks, protected block 504th~511th)
0	1	0	1	5 (16 blocks, protected block 496th~511th)
0	1	1	0	6 (32 blocks, protected block 480th~511th)
0	1	1	1	7 (64 blocks, protected block 448th~511th)
1	0	0	0	8 (128 blocks, protected block 384th~511th)
1	0	0	1	9 (256 blocks, protected block 256th~511th)
1	0	1	0	10 (512 blocks, protected all)
1	0	1	1	11 (512 blocks, protected all)
1	1	0	0	12 (512 blocks, protected all)
1	1	0	1	13 (512 blocks, protected all)
1	1	1	0	14 (512 blocks, protected all)
1	1	1	1	15 (512 blocks, protected all)

Protected Area Sizes (T/B bit = 1)

Status bit				Protect Level
BP3	BP2	BP1	BP0	256Mb
0	0	0	0	0 (none)
0	0	0	1	1 (1 block, protected block 0th)
0	0	1	0	2 (2 blocks, protected block 0th~1st)
0	0	1	1	3 (4 blocks, protected block 0th~3rd)
0	1	0	0	4 (8 blocks, protected block 0th~7th)
0	1	0	1	5 (16 blocks, protected block 0th~15th)
0	1	1	0	6 (32 blocks, protected block 0th~31st)
0	1	1	1	7 (64 blocks, protected block 0th~63rd)
1	0	0	0	8 (128 blocks, protected block 0th~127th)
1	0	0	1	9 (256 blocks, protected block 0th~255th)
1	0	1	0	10 (512 blocks, protected all)
1	0	1	1	11 (512 blocks, protected all)
1	1	0	0	12 (512 blocks, protected all)
1	1	0	1	13 (512 blocks, protected all)
1	1	1	0	14 (512 blocks, protected all)
1	1	1	1	15 (512 blocks, protected all)



II. Additional 4K-bit secured OTP for unique identifier: to provide 4K-bit one-time program area for setting device unique serial number - Which may be set by factory or system customer.

- Security register bit 0 indicates whether the Secured OTP area is locked by factory or not.
- To program the 4K-bit secured OTP by entering 4K-bit secured OTP mode (with Enter Security OTP command), and going through normal program procedure, and then exiting 4K-bit secured OTP mode by writing Exit Security OTP command.
- Customer may lock-down the customer lockable secured OTP by writing WRSCUR(write security register) command to set customer lock-down bit1 as "1". Please refer to ["Table 12. Security Register Definition"](#) for security register bit definition and ["Table 3. 4K-bit Secured OTP Definition"](#) for address range definition.
- Note: Once lock-down whatever by factory or customer, it cannot be changed any more. While in 4K-bit secured OTP mode, array access is not allowed.

Table 3. 4K-bit Secured OTP Definition

Address range	Size	Standard Factory Lock	Customer Lock
xxx000-xxx00F	128-bit	ESN (electrical serial number)	Determined by customer
xxx010-xxx1FF	3968-bit	N/A	

7. Memory Organization

Table 4. Memory Organization

	Block(64K-byte)	Block(32K-byte)	Sector	Address Range			
individual block lock/unlock unit:64K-byte	511	1023	8191	1FFF000h	1FFFFFFh	individual 16 sectors lock/unlock unit:4K-byte	
			⋮	⋮	⋮		
			8184	1FF8000h	1FF8FFFh		
		1022	8183	1FF7000h	1FF7FFFh		
			⋮	⋮	⋮		
			8176	1FF0000h	1FF0FFFh		
	510	1021	8175	1FEF000h	1FEFFFFh		
			⋮	⋮	⋮		
			8168	1FE8000h	1FE8FFFh		
		1020	8167	1FE7000h	1FE7FFFh		
⋮			⋮	⋮			
8160			1FE0000h	1FE0FFFh			
509	1019	8159	1FDF000h	1FDFFFFh			
		⋮	⋮	⋮			
		8152	1FD8000h	1FD8FFFh			
	1018	8151	1FD7000h	1FD7FFFh			
		⋮	⋮	⋮			
		8144	1FD0000h	1FD0FFFh			

individual block
lock/unlock unit:64K-byte



individual block lock/unlock unit:64K-byte	2	5	47	002F000h	002FFFFh	individual 16 sectors lock/unlock unit:4K-byte	
			⋮	⋮	⋮		
			40	0028000h	0028FFFh		
		4	39	027000h	0027FFFh		
			⋮	⋮	⋮		
			32	0020000h	0020FFFh		
	1	3	31	001F000h	001FFFFh		
			⋮	⋮	⋮		
			24	0018000h	0018FFFh		
		2	23	0017000h	0017FFFh		
⋮			⋮	⋮			
16			0010000h	0010FFFh			
0	1	15	000F000h	000FFFFh			
		⋮	⋮	⋮			
		8	0008000h	0008FFFh			
	0	7	0007000h	0007FFFh			
		⋮	⋮	⋮			
		0	0000000h	0000FFFh			

8. DEVICE OPERATION

1. Before a command is issued, status register should be checked to ensure device is ready for the intended operation.
2. When incorrect command is inputted to this device, this device becomes standby mode and keeps the standby mode until next CS# falling edge. In standby mode, SO pin of this device should be High-Z.
3. When correct command is inputted to this device, this device becomes active mode and keeps the active mode until next CS# rising edge.
4. Input data is latched on the rising edge of Serial Clock (SCLK) and data shifts out on the falling edge of SCLK. The difference of Serial mode 0 and mode 3 is shown as "*Figure 1. Serial Modes Supported*".
5. For the following instructions: RDID, RDSR, RDSCUR, READ/READ4B, FAST_READ/FAST_READ4B, 2READ/2READ4B, DREAD/DREAD4B, 4READ/4READ4B, QREAD/QREAD4B, RDSFDP, RES, REMS, QPIID, RDDPB, RDSPB, RDLR, RDEAR, RDCR, the shifted-in instruction sequence is followed by a data-out sequence. After any bit of data being shifted out, the CS# can be high. For the following instructions: WREN, WRDI, WRSR, SE/SE4B, BE32K/BE32K4B, BE/BE4B, CE, PP/PP4B, 4PP/4PP4B, DP, ENSO, EXSO, WRSCUR, EN4B, EX4B, WPSEL, GBLK, GBULK, SUSPEND, RESUME, NOP, RSTEN, RST, EQIO, RSTQIO the CS# must go high exactly at the byte boundary; otherwise, the instruction will be rejected and not executed.
6. During the progress of Write Status Register, Program, Erase operation, to access the memory array is neglected and not affect the current operation of Write Status Register, Program, Erase.

Figure 1. Serial Modes Supported

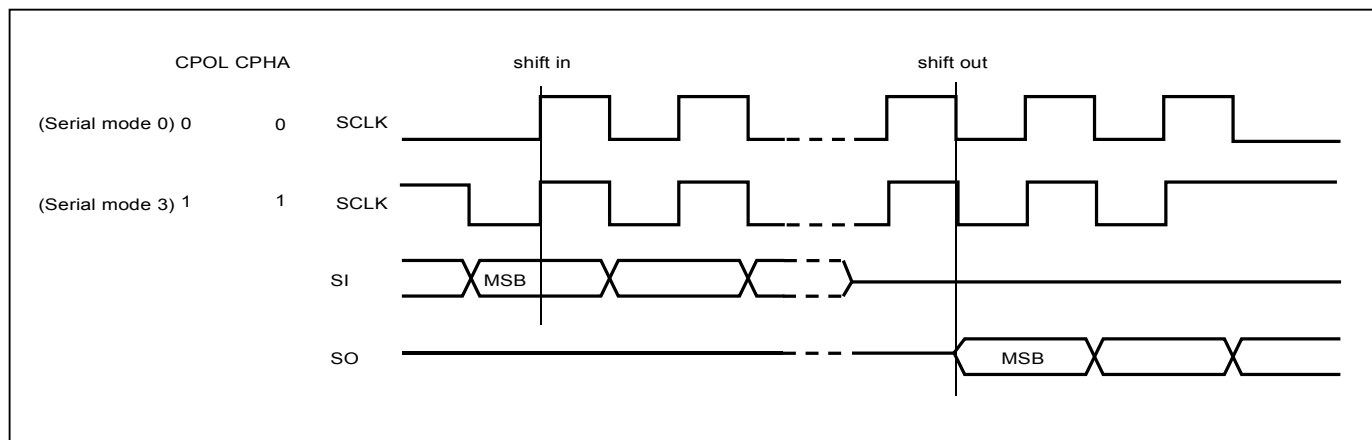

Note:

CPOL indicates clock polarity of Serial master, CPOL=1 for SCLK high while idle, CPOL=0 for SCLK low while not transmitting. CPHA indicates clock phase. The combination of CPOL bit and CPHA bit decides which Serial mode is supported.

Figure 2. Serial Input Timing

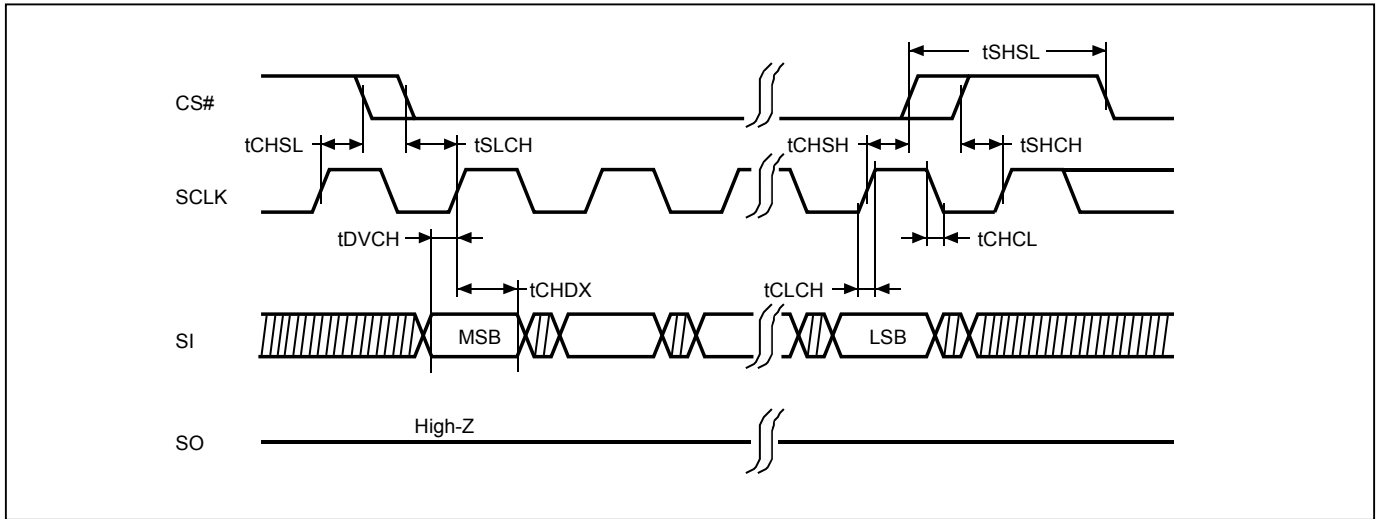

Figure 3. Serial Input Timing (DTR mode)

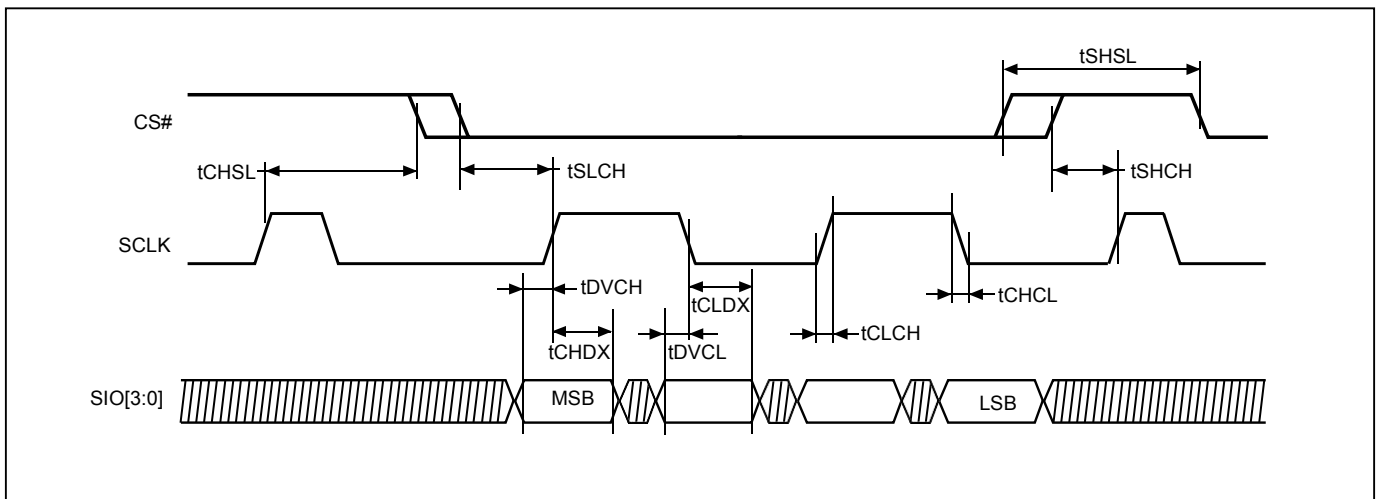

Figure 4. Output Timing (STR mode)

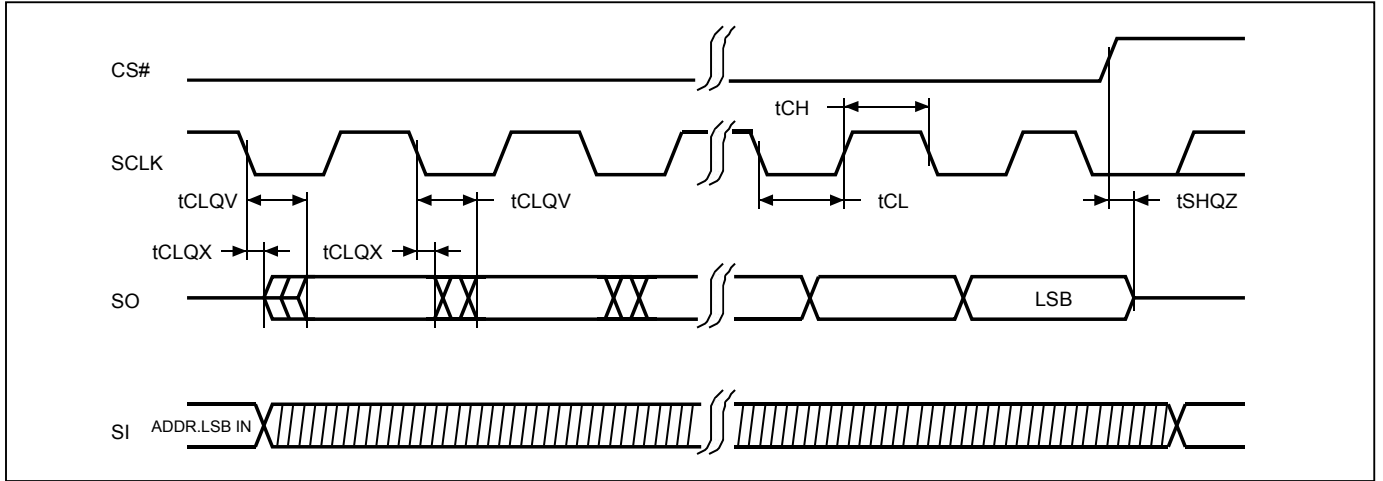
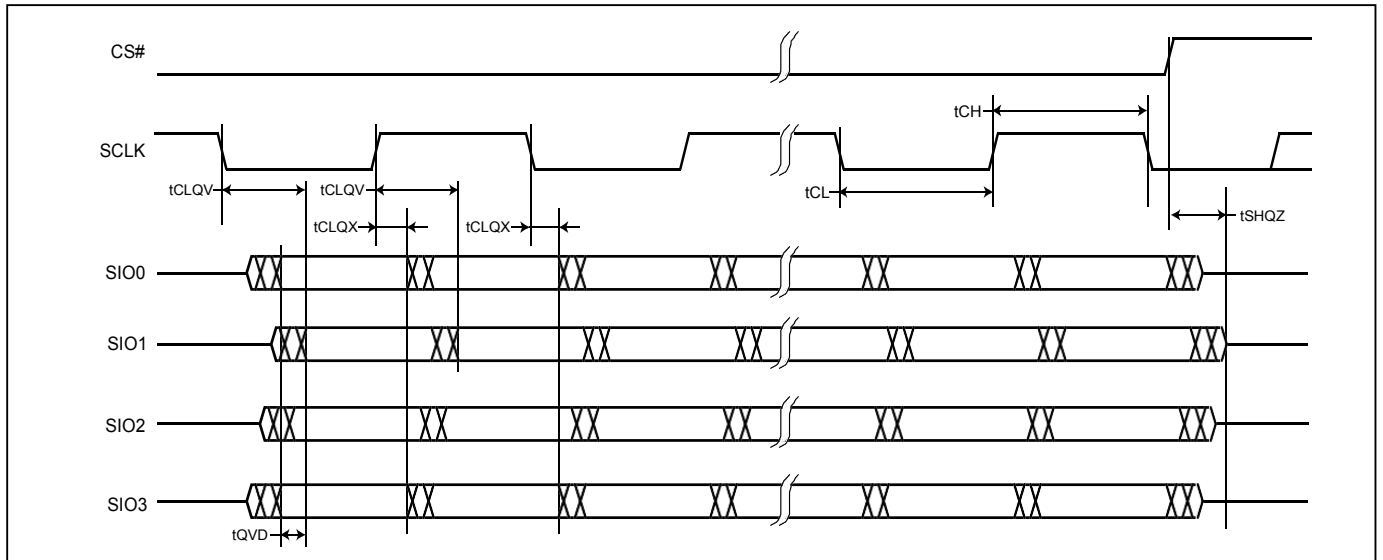

Figure 5. Output Timing (DTR mode)



8-1. 256Mb Address Protocol

The original 24 bit address protocol of Serial NOR Flash can only access density size below 128Mb. For the memory device of 256Mb and above, the 32bit address is requested for access higher memory size. The MX25L25673G provides three different methods to access the whole 256Mb density:

(1) Command entry 4-byte address mode: Issue Enter 4-Byte mode command to set up the 4BYTE bit in Configuration Register bit. After 4BYTE bit has been set, the number of address cycle become 32-bit.

(2) Extended Address Register (EAR): configure the memory device into two 128Mb segments to select which one is active through the EAR bit "0".

(3) 4-byte Address Command Set: When issuing 4-byte address command set, 4-byte address (A31-A0) is requested after the instruction code. Please note that it is not necessary to issue EN4B command before issuing any of 4-byte command set.

Enter 4-Byte Address Mode

In 4-byte Address mode, all instructions are 32-bits address clock cycles. By using EN4B and EX4B to enable and disable the 4-byte address mode.

When 4-byte address mode is enabled, the EAR<0> becomes "don't care" for all instructions requiring 4-byte address. The EAR function will be disabled when 4-byte mode is enabled.

Extended Address Register (Configurable)

The device provides an 8-bit volatile register for extended Address Register: it identifies the extended address (A31~A24) above 128Mb density by using original 3-byte address.

Extended Address Register (EAR)

Bit 7	Bit 6	Bit 5	Bit 4	Bit 3	Bit 2	Bit 1	Bit 0
A31	A30	A29	A28	A27	A26	A25	A24

For the MX25L25673G the A31 to A25 are Don't Care. During EAR, reading these bits will read as 0. The bit 0 is default as "0".

Figure 6. Top and Bottom 128M bits

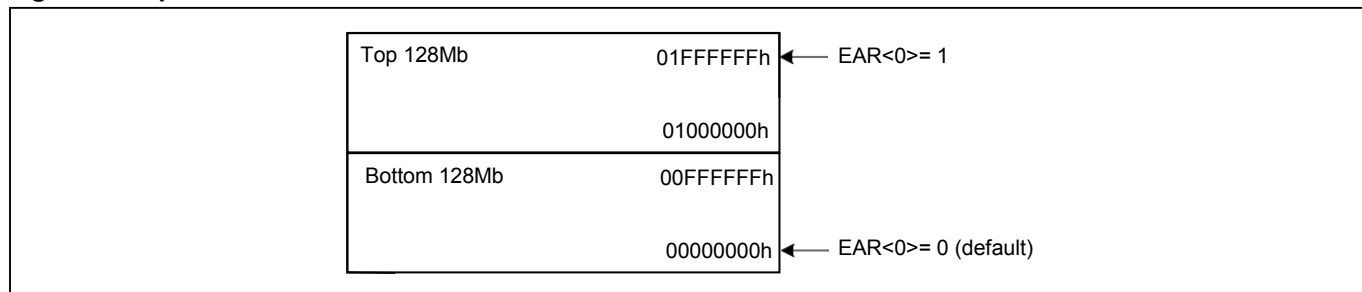

When under EAR mode, Read, Program, Erase operates in the selected segment by using 3-byte address mode.

For the read operation, the whole array data can be continually read out with one command. Data output starts from the selected top or bottom 128Mb, but it can cross the boundary. When the last byte of the segment is reached, the next byte (in a continuous reading) is the first byte of the next segment. However, the EAR (Extended Address Register) value does not change. The random access reading can only be operated in the selected segment.

The Chip erase command will erase the whole chip and is not limited by EAR selected segment.

8-2. Quad Peripheral Interface (QPI) Read Mode

QPI protocol enables user to take full advantage of Quad I/O Serial NOR Flash by providing the Quad I/O interface in command cycles, address cycles and as well as data output cycles.

Enable QPI mode

By issuing command EQIO(35h), the QPI mode is enabled. After QPI mode is enabled, the device enters quad mode (4-4-4) without QE bit status changed.

Figure 7. Enable QPI Sequence

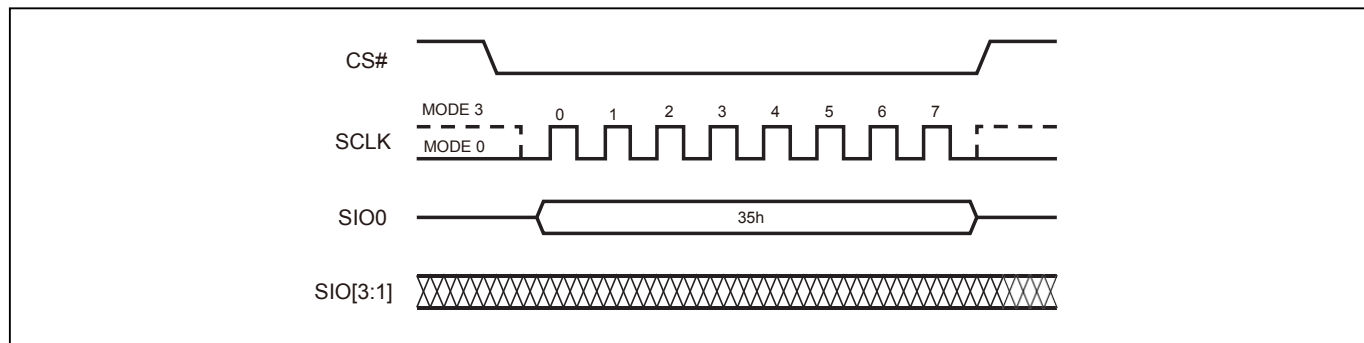

Reset QPI (RSTQIO)

To reset the QPI mode, the RSTQIO (F5h) command is required. After the RSTQIO command is issued, the device returns from QPI mode (4 I/O interface in command cycles) to SPI mode (1 I/O interface in command cycles).

Note:

For EQIO and RSTQIO commands, CS# high width has to follow "From Write/Erase/Program to Read Status Register" specification of tSHSL (defined in "Table 25. AC CHARACTERISTICS (Temperature = -40°C to 85°C, VCC = 2.7V - 3.6V)") for next instruction.

Figure 8. Reset QPI Mode

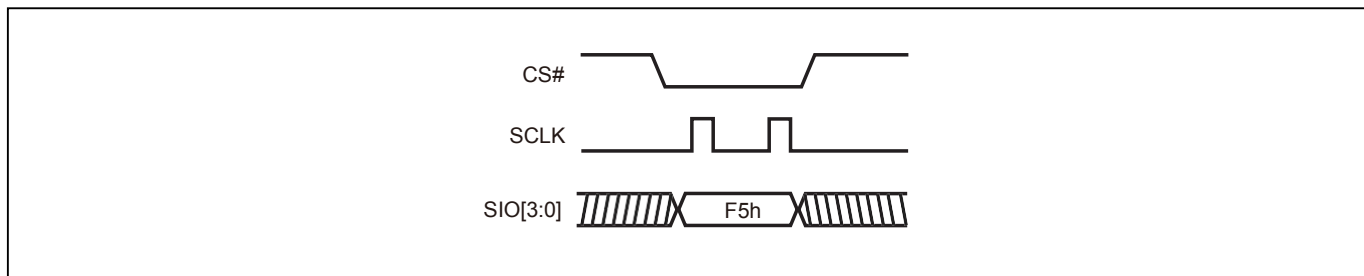

9. COMMAND DESCRIPTION
Table 5. Command Set
Read/Write Array Commands

Command (byte)	READ (normal read)	FAST READ (fast read data)	2READ (2 x I/O read command)	DREAD (1I 2O read)	4READ (4 x I/O read command)	QREAD (1I 4O read)	4DTRD (Quad I/O DT Read)
Mode	SPI	SPI	SPI	SPI	SPI/QPI	SPI	SPI/QPI
Address Bytes	3/4	3/4	3/4	3/4	3/4	3/4	3/4
1st byte	03 (hex)	0B (hex)	BB (hex)	3B (hex)	EB (hex)	6B (hex)	ED (hex)
2nd byte	ADD1	ADD1	ADD1	ADD1	ADD1	ADD1	ADD1
3rd byte	ADD2	ADD2	ADD2	ADD2	ADD2	ADD2	ADD2
4th byte	ADD3	ADD3	ADD3	ADD3	ADD3	ADD3	ADD3
5th byte		Dummy*	Dummy*	Dummy*	Dummy*	Dummy*	Dummy*
Data Cycles							
Action	n bytes read out until CS# goes high	n bytes read out until CS# goes high	n bytes read out by 2 x I/O until CS# goes high	n bytes read out by Dual output until CS# goes high	n bytes read out by 4 x I/O until CS# goes high	n bytes read out by Quad output until CS# goes high	n bytes read out (Double Transfer Rate) by 4xI/O until CS# goes high

Command (byte)	PP (page program)	4PP (quad page program)	SE (sector erase)	BE 32K (block erase 32KB)	BE (block erase 64KB)	CE (chip erase)
Mode	SPI/QPI	SPI	SPI/QPI	SPI/QPI	SPI/QPI	SPI/QPI
Address Bytes	3/4	3/4	3/4	3/4	3/4	0
1st byte	02 (hex)	38 (hex)	20 (hex)	52 (hex)	D8 (hex)	60 or C7 (hex)
2nd byte		ADD1	ADD1	ADD1	ADD1	
3rd byte		ADD2	ADD2	ADD2	ADD2	
4th byte		ADD3	ADD3	ADD3	ADD3	
5th byte						
Data Cycles	1-256	1-256				
Action	to program the selected page	quad input to program the selected page	to erase the selected sector	to erase the selected 32K block	to erase the selected block	to erase whole chip

* Dummy cycle numbers will be different depending on the bit6 & bit 7 (DC0 & DC1) setting in configuration register.

Read/Write Array Commands (4 Byte Address Command Set)

Command (byte)	READ4B	FAST READ4B	2READ4B	DREAD4B	4READ4B	QREAD4B
Mode	SPI	SPI	SPI	SPI	SPI/QPI	SPI
Address Bytes	4	4	4	4	4	4
1st byte	13 (hex)	0C (hex)	BC (hex)	3C (hex)	EC (hex)	6C (hex)
2nd byte	ADD1	ADD1	ADD1	ADD1	ADD1	ADD1
3rd byte	ADD2	ADD2	ADD2	ADD2	ADD2	ADD2
4th byte	ADD3	ADD3	ADD3	ADD3	ADD3	ADD3
5th byte	ADD4	ADD4	ADD4	ADD4	ADD4	ADD4
6th byte		Dummy	Dummy	Dummy	Dummy	Dummy
Data Cycles						
Action	read data byte by 4 byte address	read data byte by 4 byte address	read data byte by 2 x I/O with 4 byte address	Read data byte by Dual Output with 4 byte address	read data byte by 4 x I/O with 4 byte address	Read data byte by Quad Output with 4 byte address

Command (byte)	4DTRD4B (Quad I/O DT Read)	PP4B	4PP4B	BE4B (block erase 64KB)	BE32K4B (block erase 32KB)	SE4B (Sector erase 4KB)
Mode	SPI/QPI	SPI/QPI	SPI	SPI/QPI	SPI/QPI	SPI/QPI
Address Bytes	3/4	4	4	4	4	4
1st byte	EE (hex)	12 (hex)	3E (hex)	DC (hex)	5C (hex)	21 (hex)
2nd byte	ADD1	ADD1	ADD1	ADD1	ADD1	ADD1
3rd byte	ADD2	ADD2	ADD2	ADD2	ADD2	ADD2
4th byte	ADD3	ADD3	ADD3	ADD3	ADD3	ADD3
5th byte	ADD4	ADD4	ADD4	ADD4	ADD4	ADD4
6th byte	Dummy*					
Data Cycles		1-256	1-256			
Action	n bytes read out (Double Transfer Rate) by 4xI/O until CS# goes high	to program the selected page with 4byte address	Quad input to program the selected page with 4byte address	to erase the selected (64KB) block with 4byte address	to erase the selected (32KB) block with 4byte address	to erase the selected (4KB) sector with 4byte address

Register/Setting Commands

Command (byte)	WREN (write enable)	WRDI (write disable)	FMEN (factory mode enable)	RDSR (read status register)	RDCR (read configuration register)	WRSR (write status/configuration register)	RDEAR (read extended address register)
Mode	SPI/QPI	SPI/QPI	SPI/QPI	SPI/QPI	SPI/QPI	SPI/QPI	SPI/QPI
1st byte	06 (hex)	04 (hex)	41 (hex)	05 (hex)	15 (hex)	01 (hex)	C8 (hex)
2nd byte						Values	
3rd byte						Values	
4th byte							
5th byte							
Data Cycles						1-2	
Action	sets the (WEL) write enable latch bit	resets the (WEL) write enable latch bit	enable factory mode	to read out the values of the status register	to read out the values of the configuration register	to write new values of the status/configuration register	read extended address register

Command (byte)	WREAR (write extended address register)	WPSEL (Write Protect Selection)	EQIO (Enable QPI)	RSTQIO (Reset QPI)	EN4B (enter 4-byte mode)	EX4B (exit 4-byte mode)	PGM/ERS Suspend (Suspends Program/Erase)
Mode	SPI/QPI	SPI	SPI	QPI	SPI/QPI	SPI/QPI	SPI/QPI
1st byte	C5 (hex)	68 (hex)	35 (hex)	F5 (hex)	B7 (hex)	E9 (hex)	B0 (hex)
2nd byte							
3rd byte							
4th byte							
5th byte							
Data Cycles	1						
Action	write extended address register	to enter and enable individual block protect mode	Entering the QPI mode	Exiting the QPI mode	to enter 4-byte mode and set 4BYTE bit as "1"	to exit 4-byte mode and clear 4BYTE bit to be "0"	

Command (byte)	PGM/ERS Resume (Resumes Program/Erase)	DP (Deep power down)	RDP (Release from deep power down)	SBL (Set Burst Length)
Mode	SPI/QPI	SPI/QPI	SPI/QPI	SPI/QPI
1st byte	30 (hex)	B9 (hex)	AB (hex)	C0 (hex)
2nd byte				
3rd byte				
4th byte				
5th byte				
Data Cycles				
Action		enters deep power down mode	release from deep power down mode	to set Burst length

ID/Security Commands

Command (byte)	RDID (read identification)	RES (read electronic ID)	REMS (read electronic manufacturer & device ID)	QPIID (QPI ID Read)	RDSFDP	ENSO (enter secured OTP)	EXSO (exit secured OTP)
Mode	SPI	SPI/QPI	SPI	QPI	SPI/QPI	SPI/QPI	SPI/QPI
Address Bytes	0	0	0	0	3	0	0
1st byte	9F (hex)	AB (hex)	90 (hex)	AF (hex)	5A (hex)	B1 (hex)	C1 (hex)
2nd byte		x	x		ADD1		
3rd byte		x	x		ADD2		
4th byte			ADD1 (Note 1)		ADD3		
5th byte					Dummy (8)		
Action	outputs JEDEC ID: 1-byte Manufacturer ID & 2-byte Device ID	to read out 1-byte Device ID	output the Manufacturer ID & Device ID (Note 2)	ID in QPI interface	Read SFDP mode	to enter the 4K-bit secured OTP mode	to exit the 4K-bit secured OTP mode

Command (byte)	RDSCUR (read security register)	WRSCUR (write security register)	WRSPB (SPB bit program)	ESSPB (all SPB bit erase)	RDSPB (read SPB status)	GBLK (gang block lock)	GBULK (gang block unlock)
Mode	SPI/QPI	SPI/QPI	SPI	SPI	SPI	SPI	SPI
Address Bytes	0	0	4	0	4	0	0
1st byte	2B (hex)	2F (hex)	E3 (hex)	E4 (hex)	E2 (hex)	7E (hex)	98 (hex)
2nd byte			ADD1		ADD1		
3rd byte			ADD2		ADD2		
4th byte			ADD3		ADD3		
5th byte			ADD4		ADD4		
Data Cycles					1		
Action	to read value of security register	to set the lock-down bit as "1" (once lock-down, cannot be updated)				whole chip write protect	whole chip unprotect

Command (byte)	WRLR (write lock register)	RDLR (read lock register)	WRDPB (write DPB register)	RDDPB (read DPB register)
Mode	SPI	SPI	SPI	SPI
Address Bytes	0	0	4	4
1st byte	2C (hex)	2D (hex)	E1 (hex)	E0 (hex)
2nd byte			ADD1	ADD1
3rd byte			ADD2	ADD2
4th byte			ADD3	ADD3
5th byte			ADD4	ADD4
Data Cycles	2	2	1	1
Action				

Reset Commands

Command (byte)	NOP (No Operation)	RSTEN (Reset Enable)	RST (Reset Memory)
Mode	SPI/QPI	SPI/QPI	SPI/QPI
1st byte	00 (hex)	66 (hex)	99 (hex)
2nd byte			
3rd byte			
4th byte			
5th byte			
Action			

Note 1: The count base is 4-bit for ADD(2) and Dummy(2) because of 2 x I/O. And the MSB is on SO/SIO1 which is different from 1 x I/O condition.

Note 2: ADD=00H will output the manufacturer ID first and ADD=01H will output device ID first.

Note 3: It is not recommended to adopt any other code not in the command definition table, which will potentially enter the hidden mode.

Note 4: The RSTEN command must be executed before executing the RST command. If any other command is issued in-between RSTEN and RST, the RST command will be ignored.

Note 5: The number in parentheses after "Dummy" stands for how many clock cycles it has.

9-1. Write Enable (WREN)

The Write Enable (WREN) instruction is for setting Write Enable Latch (WEL) bit. For those instructions like PP/PP4B, 4PP/4PP4B, SE/SE4B, BE32K/BE32K4B, BE/BE4B, CE, and WRSR, which are intended to change the device content WEL bit should be set every time after the WREN instruction setting the WEL bit.

The sequence of issuing WREN instruction is: CS# goes low→sending WREN instruction code→ CS# goes high.

Both SPI (8 clocks) and QPI (2 clocks) command cycle can accept by this instruction. The SIO[3:1] are don't care in SPI mode.

Figure 9. Write Enable (WREN) Sequence (SPI Mode)

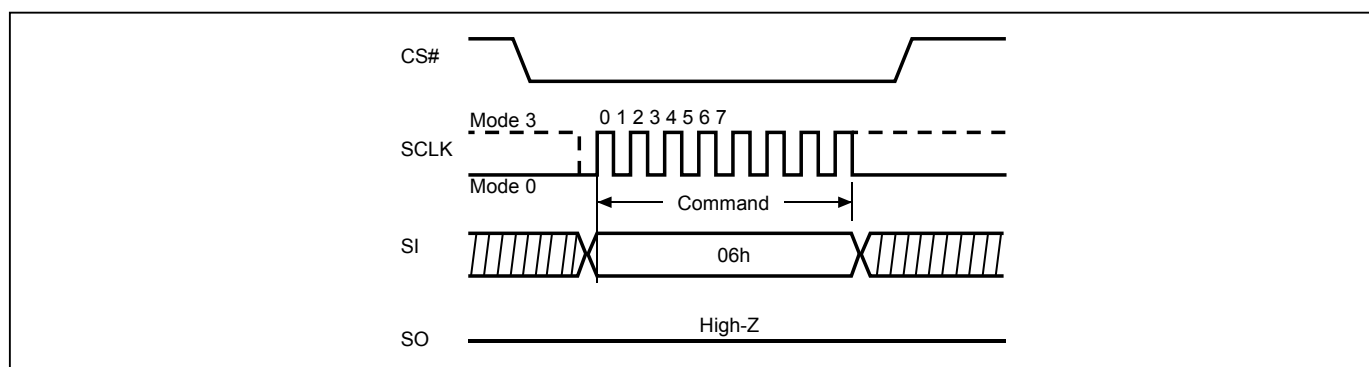
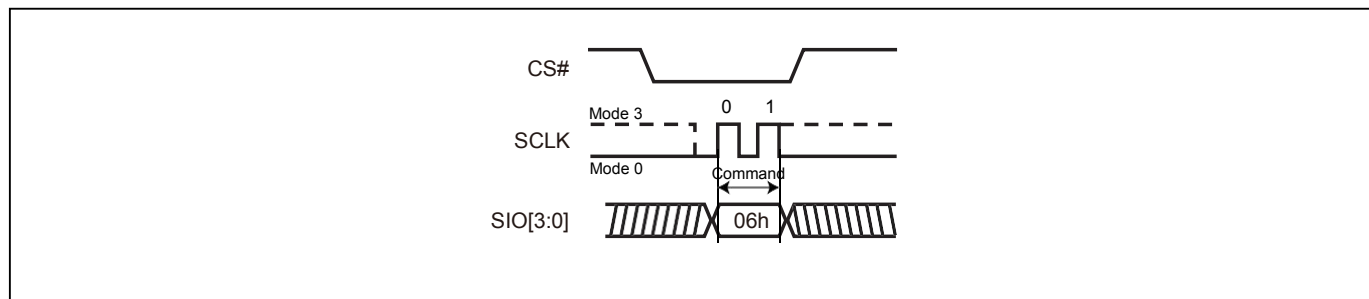

Figure 10. Write Enable (WREN) Sequence (QPI Mode)



9-2. Write Disable (WRDI)

The Write Disable (WRDI) instruction is to reset Write Enable Latch (WEL) bit.

The sequence of issuing WRDI instruction is: CS# goes low→sending WRDI instruction code→CS# goes high.

Both SPI (8 clocks) and QPI (2 clocks) command cycle can accept by this instruction. The SIO[3:1] are don't care in SPI mode.

The WEL bit is reset by following situations:

- Power-up
- Reset# pin driven low
- WRDI command completion
- WRSR command completion
- PP/PP4B command completion
- 4PP/4PP4B command completion
- SE/SE4B command completion
- BE32K/BE32K4B command completion
- BE/BE4B command completion
- CE command completion
- PGM/ERS Suspend command completion
- Softreset command completion
- WRSCUR command completion
- WPSEL command completion
- GBLK command completion
- GBULK command completion
- WREAR command completion
- WRLR command completion
- WRSPB command completion
- WRDPB command completion
- ESSPB command completion

Figure 11. Write Disable (WRDI) Sequence (SPI Mode)

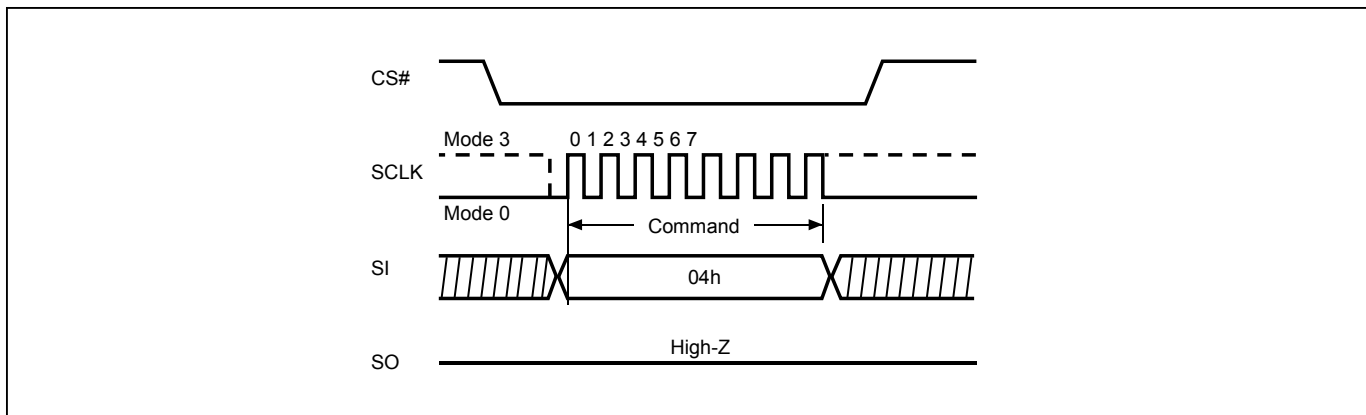
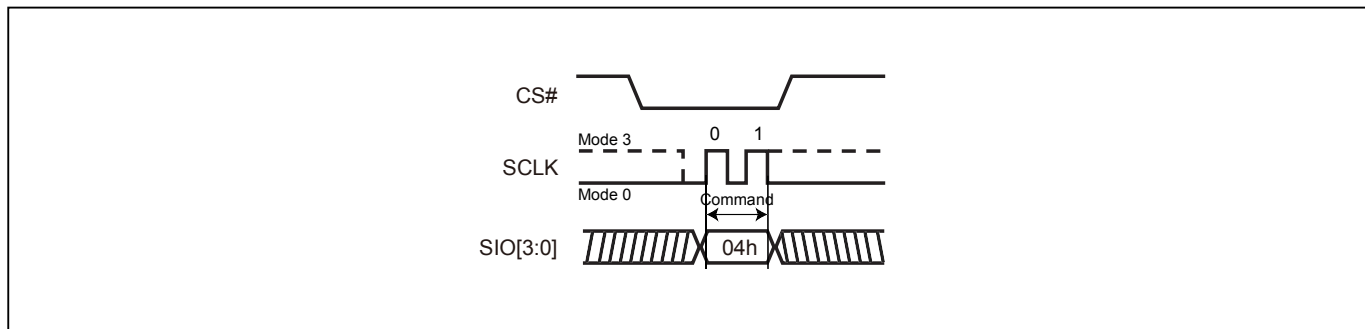

Figure 12. Write Disable (WRDI) Sequence (QPI Mode)



9-3. Factory Mode Enable (FMEN)

The Factory Mode Enable (FMEN) instruction is for enhance Program and Erase performance for increase factory production throughput. The FMEN instruction need to combine with the instructions which are intended to change the device content, like PP/PP4B, 4PP/4PP4B, SE/SE4B, BE32K/BE32K4B, BE/BE4B, and CE.

The sequence of issuing FMEN instruction is: CS# goes low→sending FMEN instruction code→ CS# goes high. A valid factory mode operation need to included three sequences: WREN instruction → FMEN instruction→ Program or Erase instruction.

Suspend command is not acceptable under factory mode.

The FMEN is reset by following situations

- Power-up
- Reset# pin driven low
- PP/PP4B command completion
- 4PP/4PP4B command completion
- SE/SE4B command completion
- BE32K/BE32K4B command completion
- BE/BE4B command completion
- CE command completion
- Softreset command completion

Both SPI (8 clocks) and QPI (2 clocks) command cycle can accept by this instruction. The SIO[3:1] are don't care in SPI mode.

Figure 13. Factory Mode Enable (FMEN) Sequence (SPI Mode)

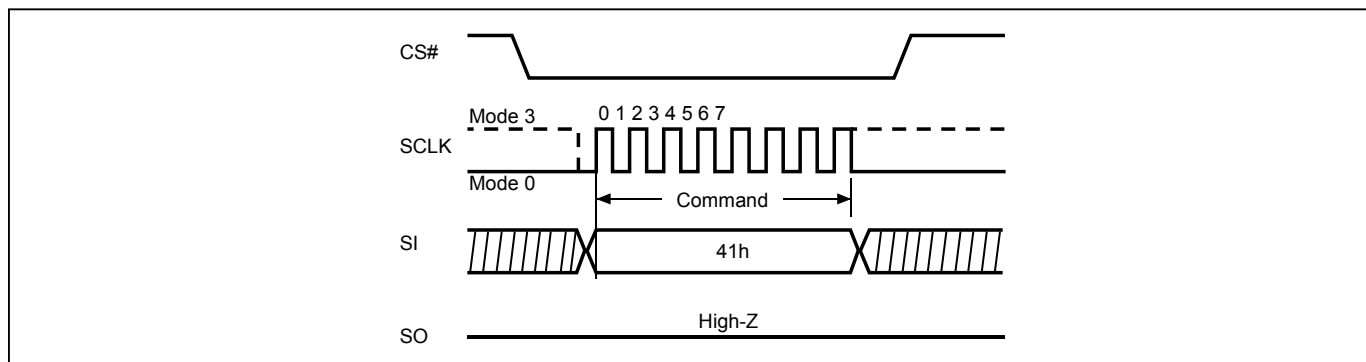
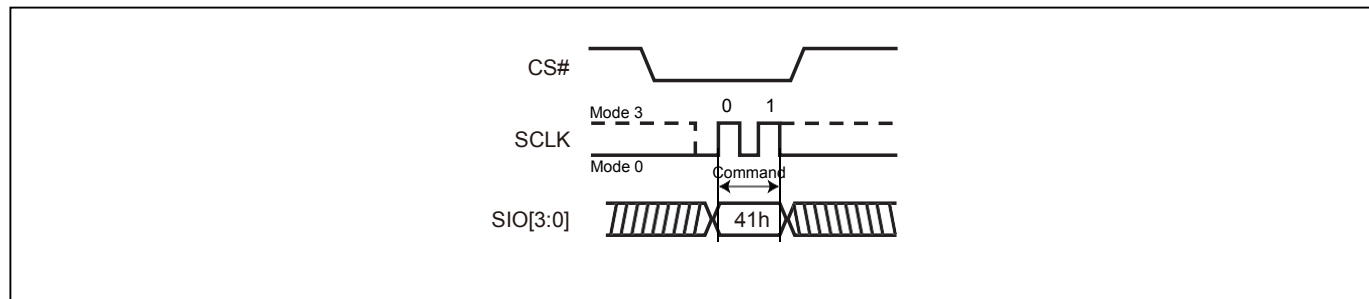

Figure 14. Factory Mode Enable (FMEN) Sequence (QPI Mode)



9-4. Read Identification (RDID)

The RDID instruction is for reading the manufacturer ID of 1-byte and followed by Device ID of 2-byte. The Macronix Manufacturer ID and Device ID are listed as [Table 6 ID Definitions](#).

The sequence of issuing RDID instruction is: CS# goes low→ sending RDID instruction code→24-bits ID data out on SO→ to end RDID operation can drive CS# to high at any time during data out.

While Program/Erase operation is in progress, it will not decode the RDID instruction, therefore there's no effect on the cycle of program/erase operation which is currently in progress. When CS# goes high, the device is at standby stage.

Figure 15. Read Identification (RDID) Sequence (SPI mode only)

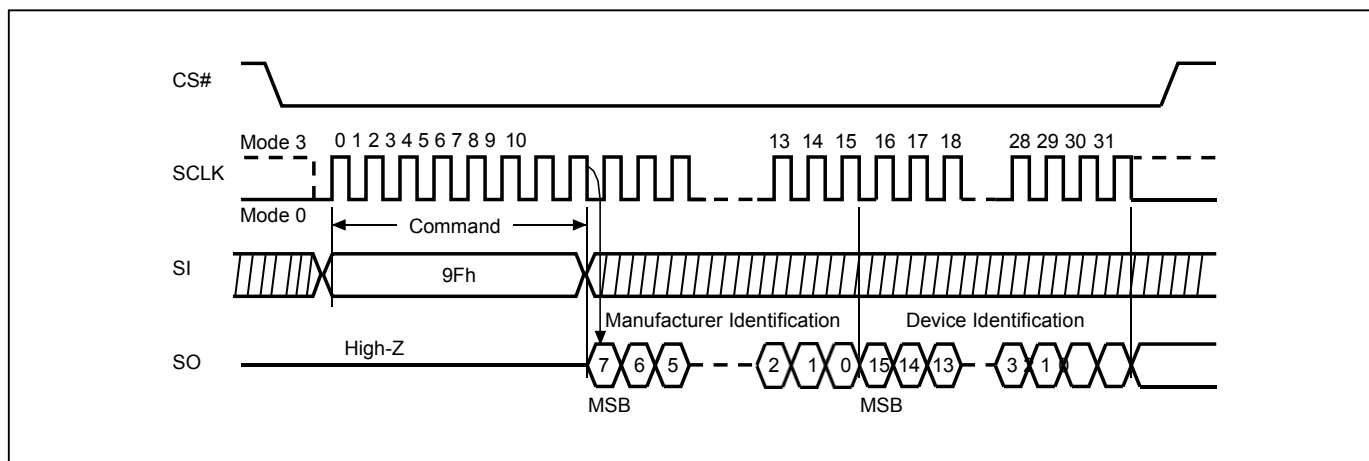

9-5. Release from Deep Power-down (RDP), Read Electronic Signature (RES)

The Release from Deep Power-down (RDP) instruction is completed by driving Chip Select (CS#) High. When Chip Select (CS#) is driven High, the device is put in the Stand-by Power mode. If the device was not previously in the Deep Power-down mode, the transition to the Stand-by Power mode is immediate. If the device was previously in the Deep Power-down mode, though, the transition to the Stand-by Power mode is delayed by t_{RES1} , and Chip Select (CS#) must remain High for at least $t_{RES1(max)}$, as specified in "Table 25. AC CHARACTERISTICS (Temperature = -40°C to 85°C, VCC = 2.7V - 3.6V)". Once in the Stand-by Power mode, the device waits to be selected, so that it can receive, decode and execute instructions. The RDP instruction is only for releasing from Deep Power Down Mode. Reset# pin goes low will release the Flash from deep power down mode.

RES instruction is for reading out the old style of 8-bit Electronic Signature, whose values are shown as "Table 6. ID Definitions". This is not the same as RDID instruction. It is not recommended to use for new design. For new design, please use RDID instruction.

Even in Deep power-down mode, the RDP and RES are also allowed to be executed, only except the device is in progress of program/erase/write cycle; there's no effect on the current program/erase/write cycle in progress.

Both SPI (8 clocks) and QPI (2 clocks) command cycle can accept by this instruction. The SIO[3:1] are don't care when during SPI mode.

The RES instruction is ended by CS# goes high after the ID been read out at least once. The ID outputs repeatedly if continuously send the additional clock cycles on SCLK while CS# is at low. If the device was not previously in Deep Power-down mode, the device transition to standby mode is immediate. If the device was previously in Deep Power-down mode, there's a delay of t_{RES2} to transit to standby mode, and CS# must remain to high at least $t_{RES2(max)}$. Once in the standby mode, the device waits to be selected, so it can be receive, decode, and execute instruction.

Figure 16. Read Electronic Signature (RES) Sequence (SPI Mode)

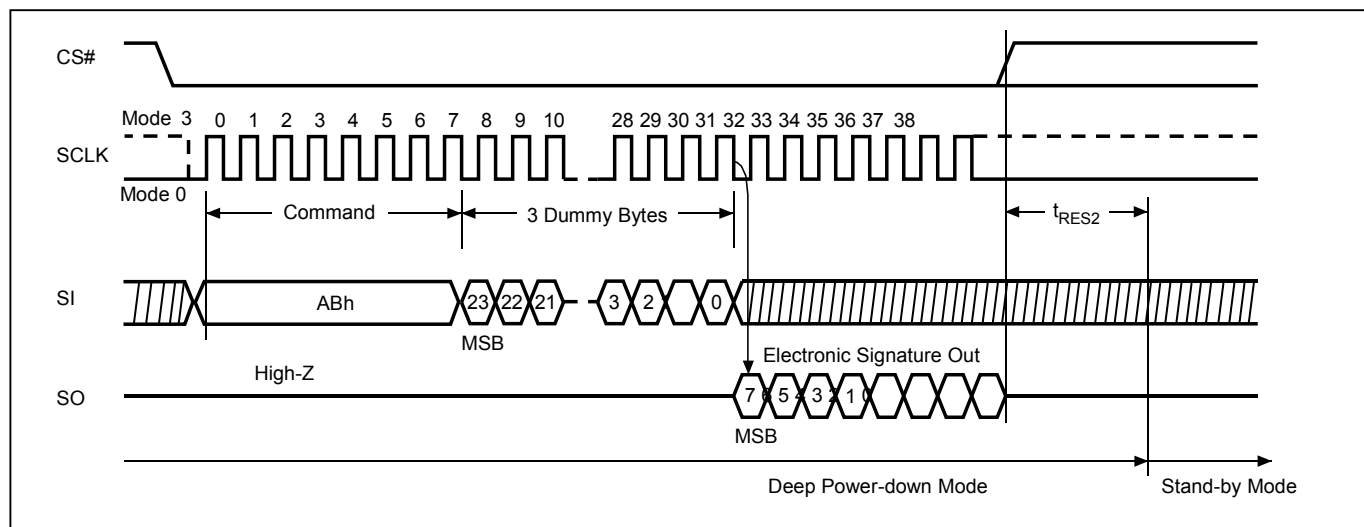

Figure 17. Read Electronic Signature (RES) Sequence (QPI Mode)

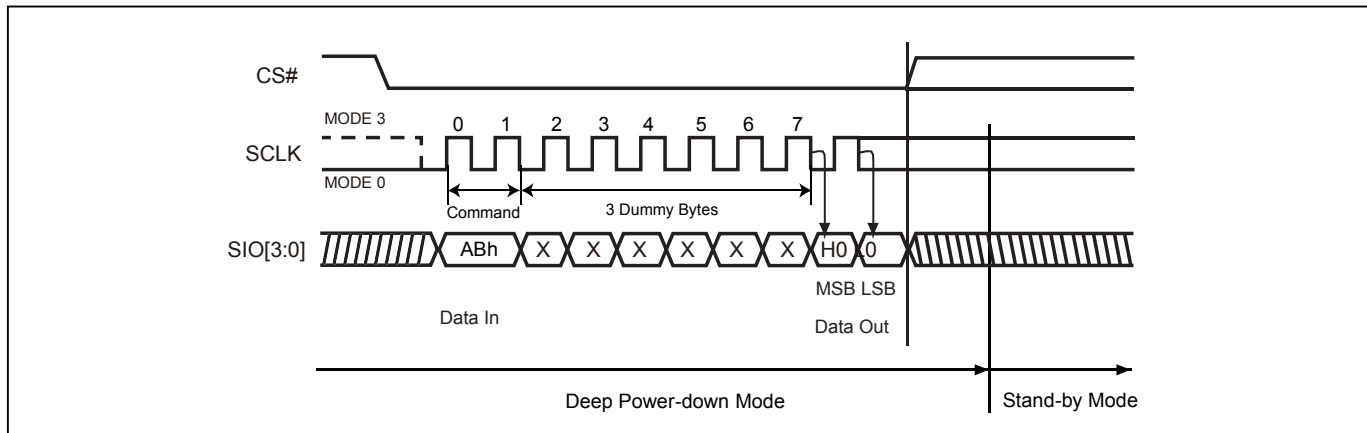

Figure 18. Release from Deep Power-down (RDP) Sequence (SPI Mode)

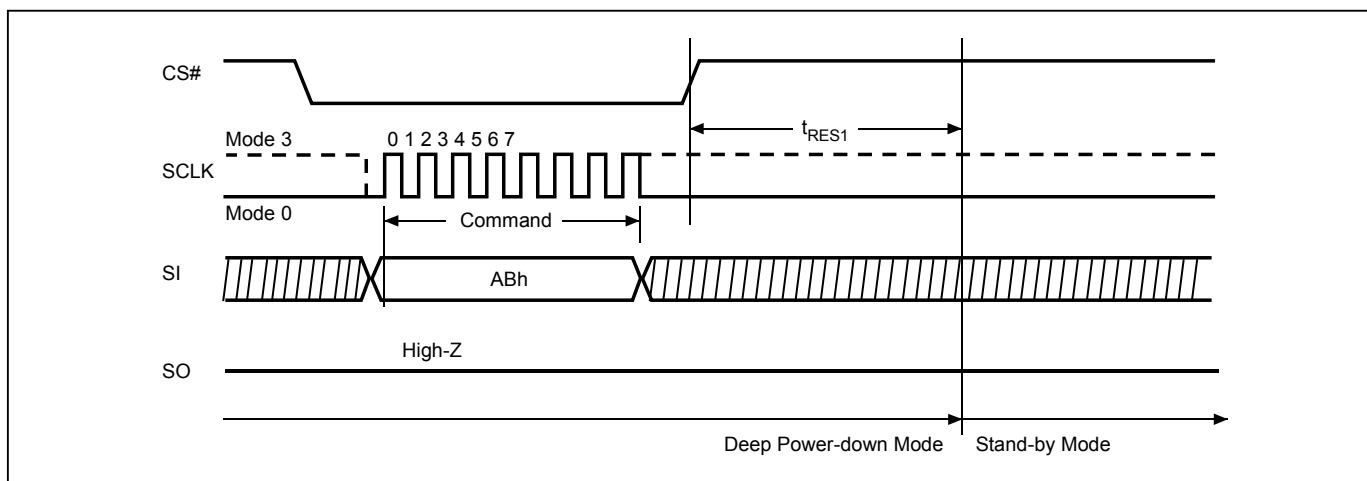
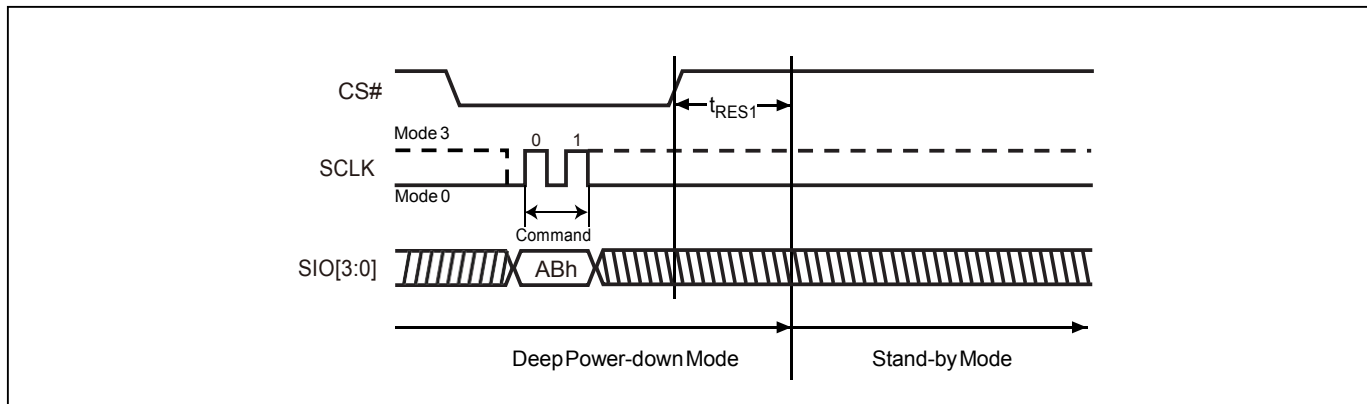

Figure 19. Release from Deep Power-down (RDP) Sequence (QPI Mode)



9-6. Read Electronic Manufacturer ID & Device ID (REMS)

The REMS instruction returns both the JEDEC assigned manufacturer ID and the device ID. The Device ID values are listed in "Table 6. ID Definitions".

The REMS instruction is initiated by driving the CS# pin low and sending the instruction code "90h" followed by two dummy bytes and one address byte (A7~A0). After which the manufacturer ID for Macronix (C2h) and the device ID are shifted out on the falling edge of SCLK with the most significant bit (MSB) first. If the address byte is 00h, the manufacturer ID will be output first, followed by the device ID. If the address byte is 01h, then the device ID will be output first, followed by the manufacturer ID. While CS# is low, the manufacturer and device IDs can be read continuously, alternating from one to the other. The instruction is completed by driving CS# high.

Figure 20. Read Electronic Manufacturer & Device ID (REMS) Sequence (SPI Mode only)

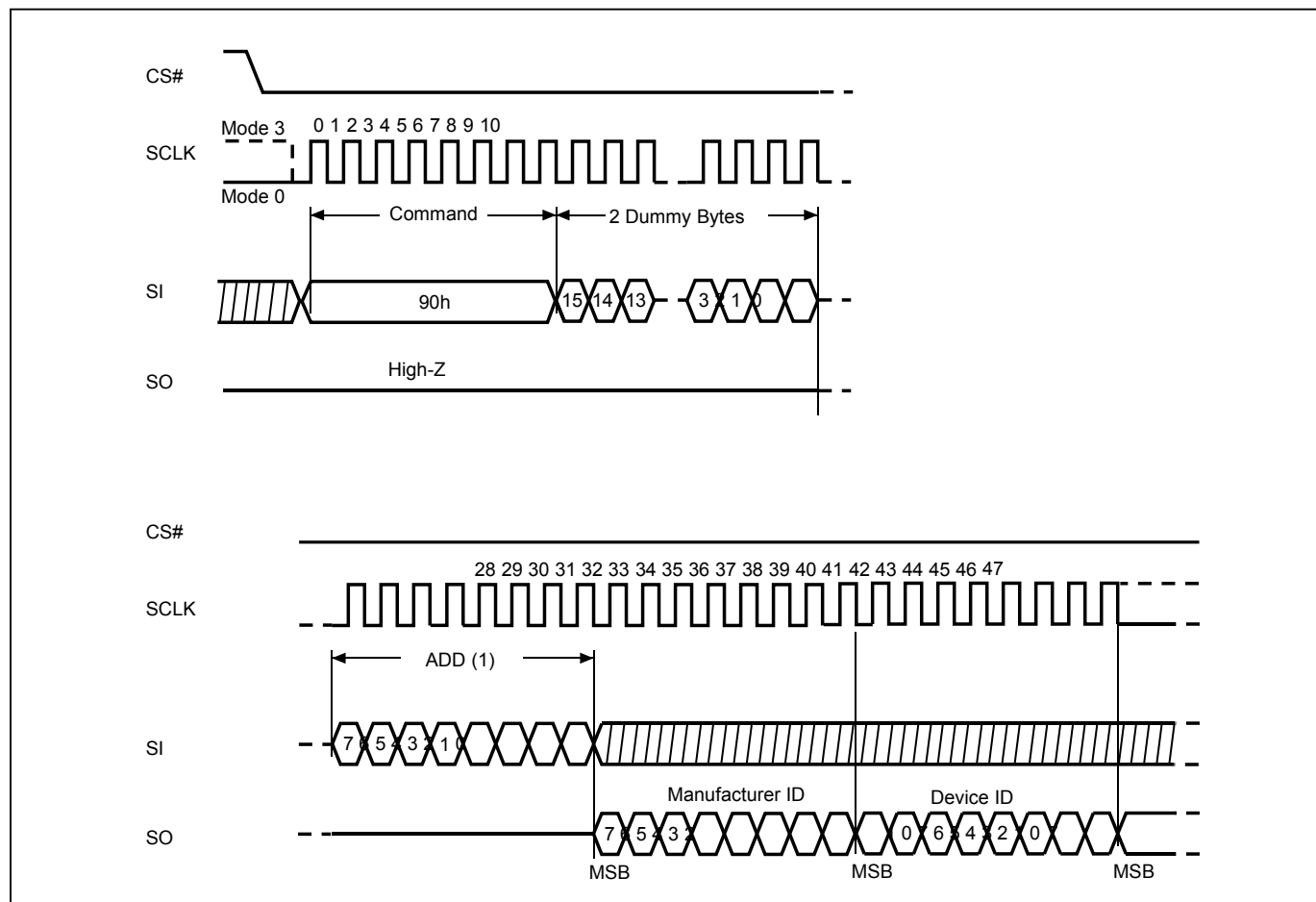

Notes:

(1) ADD=00H will output the manufacturer's ID first and ADD=01H will output device ID first.

9-7. QPI ID Read (QPIID)

User can execute this QPIID Read instruction to identify the Device ID and Manufacturer ID. The sequence of issue QPIID instruction is CS# goes low→sending QPI ID instruction→Data out on SO→CS# goes high. Most significant bit (MSB) first.

After the command cycle, the device will immediately output data on the falling edge of SCLK. The manufacturer ID, memory type, and device ID data byte will be output continuously, until the CS# goes high.

Table 6. ID Definitions

Command Type		MX25L25673G		
RDID	9Fh	Manufacturer ID	Memory type	Memory density
		C2	20	19
RES	ABh	Electronic ID		
		18		
REMS	90h	Manufacturer ID	Device ID	
		C2	18	
QPIID	AFh	Manufacturer ID	Memory type	Memory density
		C2	20	19

9-8. Read Status Register (RDSR)

The RDSR instruction is for reading Status Register Bits. The Read Status Register can be read at any time (even in program/erase/write status register condition). It is recommended to check the Write in Progress (WIP) bit before sending a new instruction when a program, erase, or write status register operation is in progress.

The sequence of issuing RDSR instruction is: CS# goes low → sending RDSR instruction code → Status Register data out on SO.

Both SPI (8 clocks) and QPI (2 clocks) command cycle can accept by this instruction. The SIO[3:1] are don't care when during SPI mode.

Figure 21. Read Status Register (RDSR) Sequence (SPI Mode)

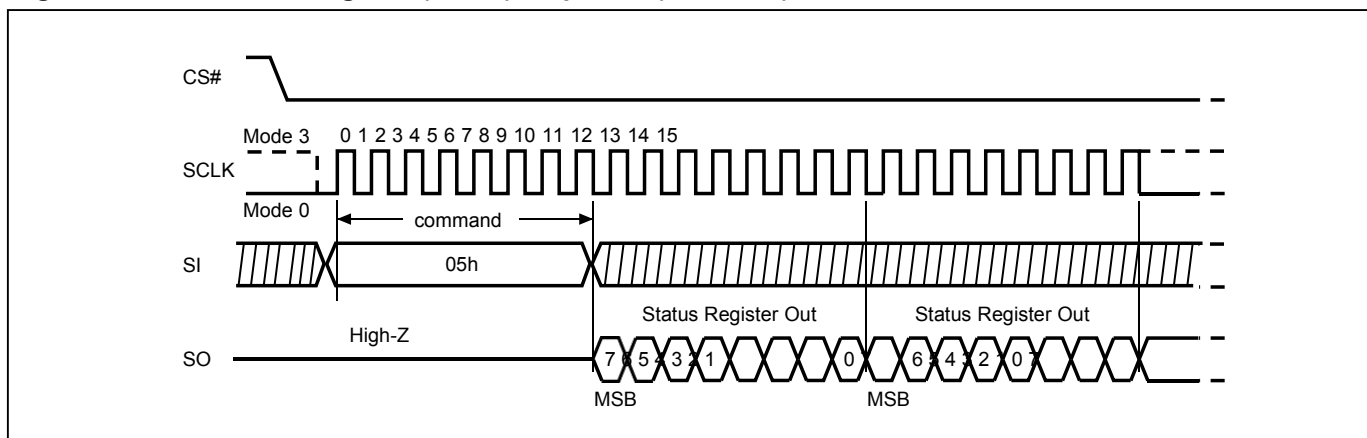
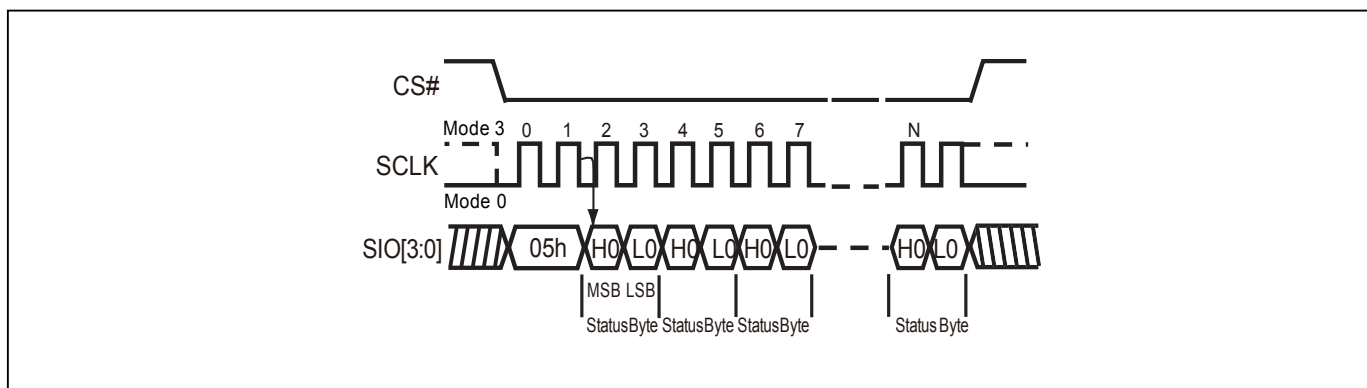

Figure 22. Read Status Register (RDSR) Sequence (QPI Mode)



9-9. Read Configuration Register (RDCR)

The RDCR instruction is for reading Configuration Register Bits. The Read Configuration Register can be read at any time (even in program/erase/write configuration register condition). It is recommended to check the Write in Progress (WIP) bit before sending a new instruction when a program, erase, or write configuration register operation is in progress.

The sequence of issuing RDCR instruction is: CS# goes low → sending RDCR instruction code → Configuration Register data out on SO.

Both SPI (8 clocks) and QPI (2 clocks) command cycle can accept by this instruction. The SIO[3:1] are don't care when during SPI mode.

Figure 23. Read Configuration Register (RDCR) Sequence (SPI Mode)

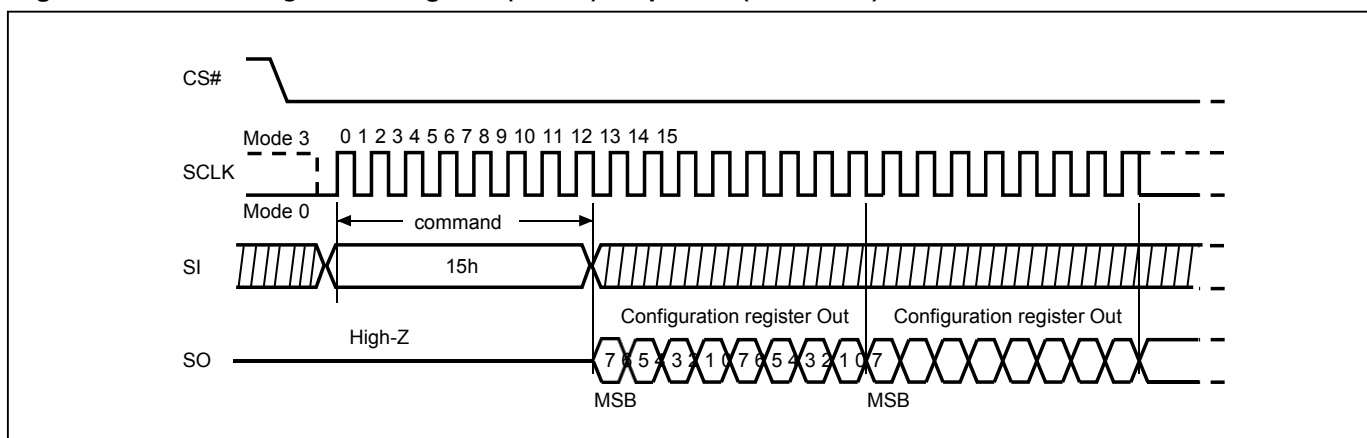
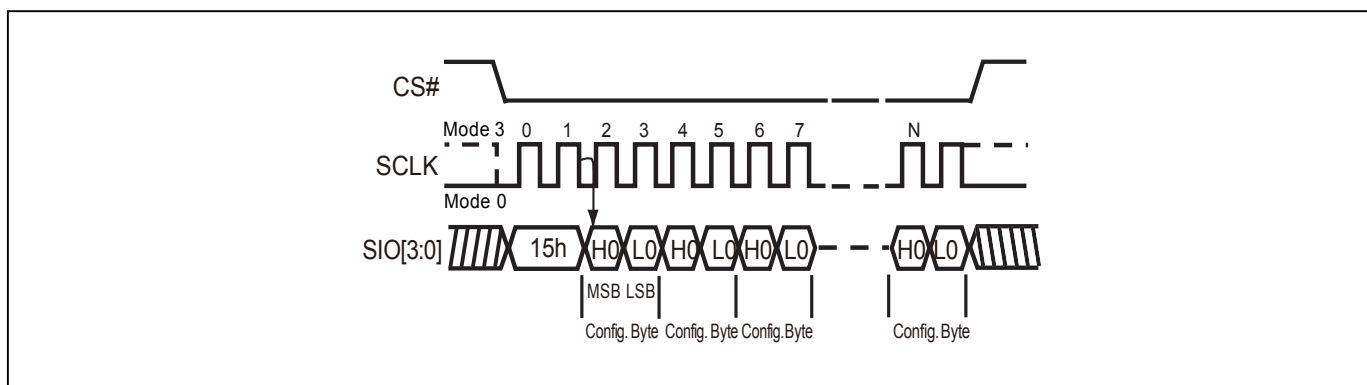

Figure 24. Read Configuration Register (RDCR) Sequence (QPI Mode)



For user to check if Program/Erase operation is finished or not, RDSR instruction flow are shown as follows:

Figure 25. Program/Erase flow with read array data

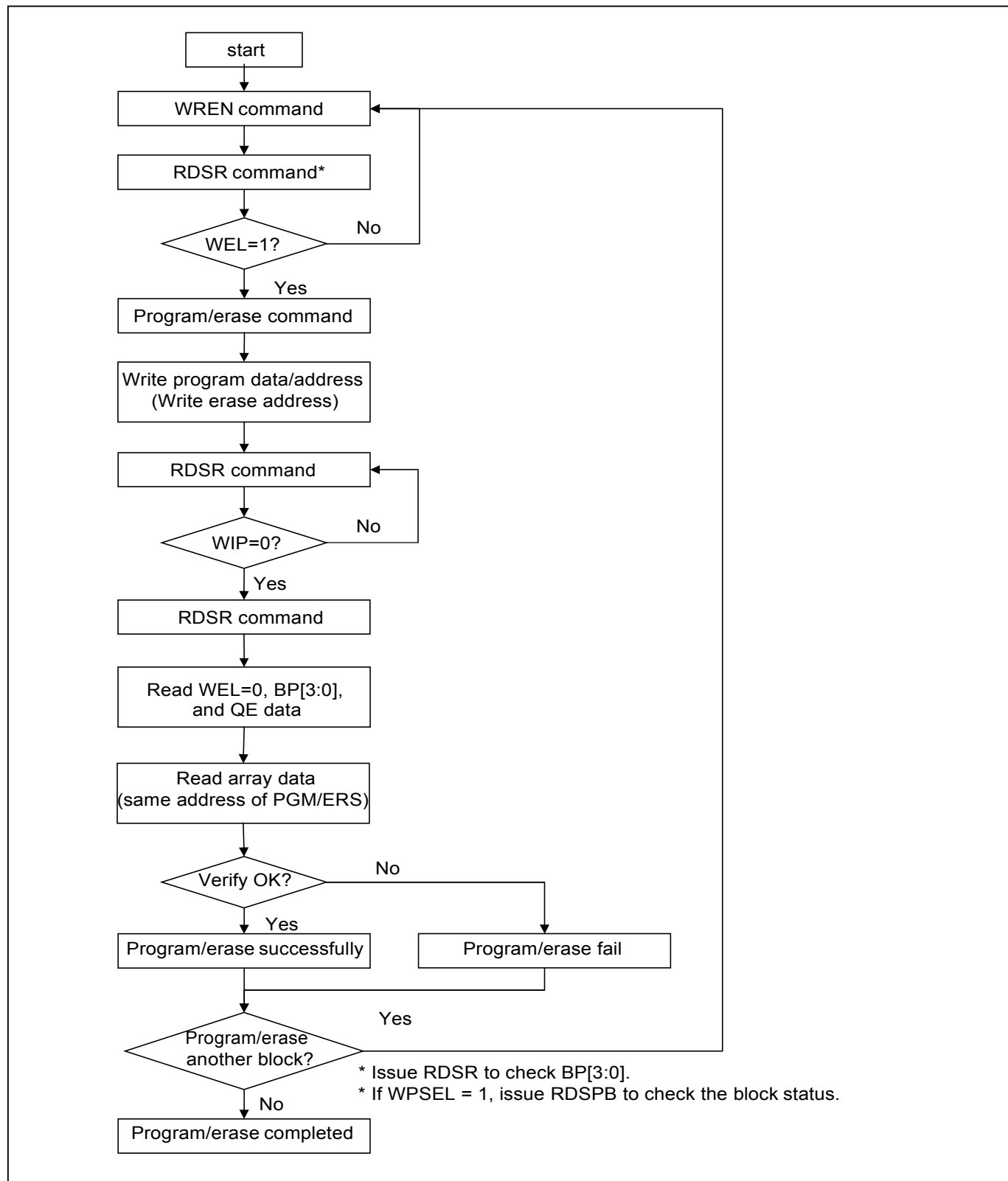
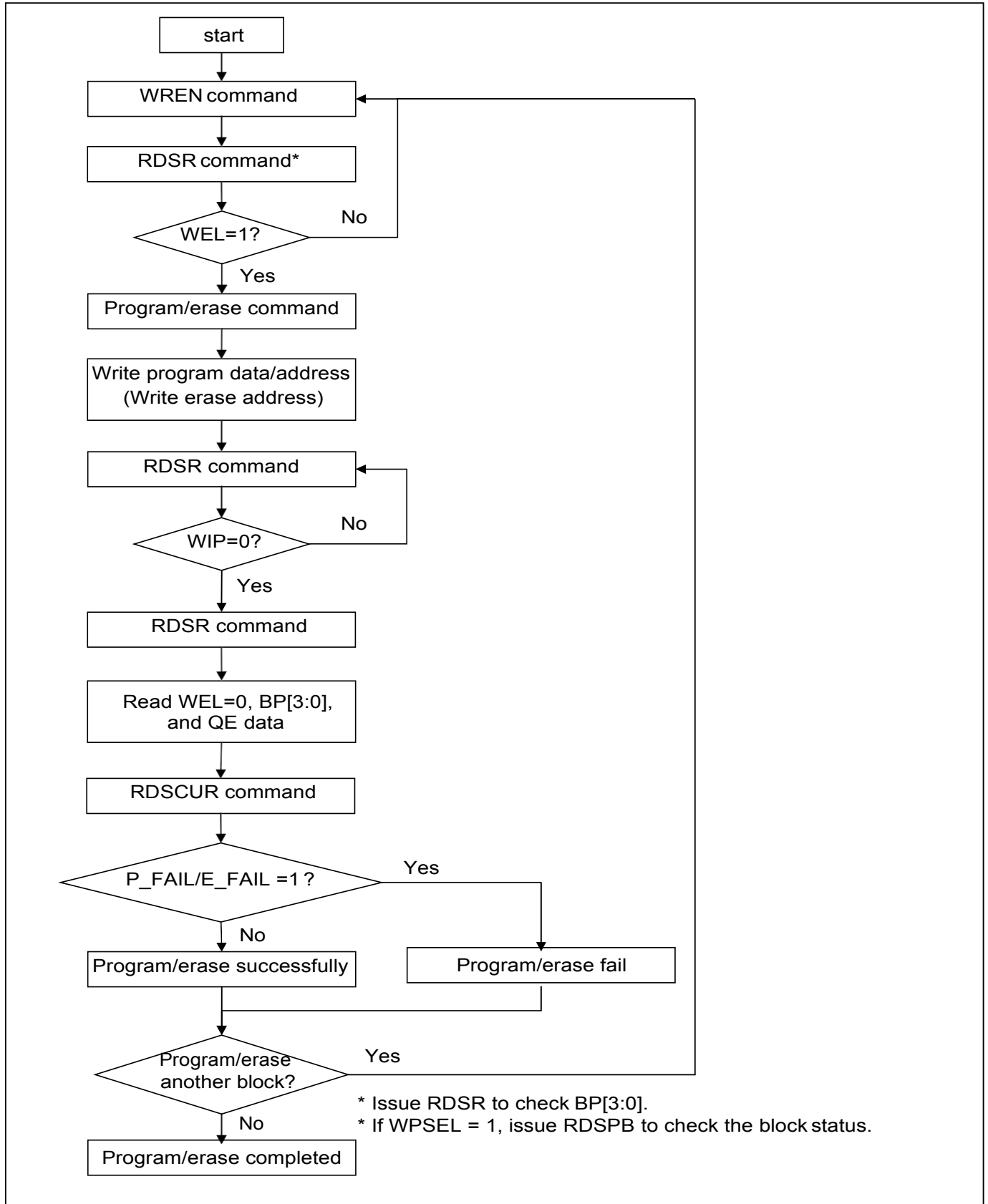

Figure 26. Program/Erase flow without read array data (read P_FAIL/E_FAIL flag)



Status Register

The definition of the status register bits is as below:

WIP bit. The Write in Progress (WIP) bit, a volatile bit, indicates whether the device is busy in program/erase/write status register progress. When WIP bit sets to 1, which means the device is busy in program/erase/write status register progress. When WIP bit sets to 0, which means the device is not in progress of program/erase/write status register cycle.

WEL bit. The Write Enable Latch (WEL) bit is a volatile bit that is set to "1" by the WREN instruction. WEL needs to be set to "1" before the device can accept program and erase instructions, otherwise the program and erase instructions are ignored. WEL automatically clears to "0" when a program or erase operation completes. To ensure that both WIP and WEL are "0" and the device is ready for the next program or erase operation, it is recommended that WIP be confirmed to be "0" before checking that WEL is also "0" (Please refer to "[Figure 29. WRSR flow](#)"). If a program or erase instruction is applied to a protected memory area, the instruction will be ignored and WEL will clear to "0".

BP3, BP2, BP1, BP0 bits. The Block Protect (BP3, BP2, BP1, BP0) bits, non-volatile bits, indicate the protected area (as defined in "[Table 2. Protected Area Sizes](#)") of the device to against the program/erase instruction without hardware protection mode being set. To write the Block Protect (BP3, BP2, BP1, BP0) bits requires the Write Status Register (WRSR) instruction to be executed. Those bits define the protected area of the memory to against Page Program (PP), Sector Erase (SE), Block Erase 32KB (BE32K), Block Erase (BE) and Chip Erase (CE) instructions (only if Block Protect bits (BP3:BP0) set to 0, the CE instruction can be executed). The BP3, BP2, BP1, BP0 bits are "0" as default. Which is unprotected.

QE bit. The Quad Enable (QE) bit, a non-volatile bit which is permanently set to "1". The flash always performs Quad I/O mode.

Table 7. Status Register

bit7	bit6	bit5	bit4	bit3	bit2	bit1	bit0
Reserved	QE (Quad Enable)	BP3 (level of protected block)	BP2 (level of protected block)	BP1 (level of protected block)	BP0 (level of protected block)	WEL (write enable latch)	WIP (write in progress bit)
Reserved	1=Quad Enable	<i>(note 1)</i>	<i>(note 1)</i>	<i>(note 1)</i>	<i>(note 1)</i>	1=write enable 0=not write enable	1=write operation 0=not in write operation
Reserved	Non-volatile bit	Non-volatile bit	Non-volatile bit	Non-volatile bit	Non-volatile bit	volatile bit	volatile bit

Note 1: Please refer to the [Table 2](#) "Protected Area Size".

Configuration Register

The Configuration Register is able to change the default status of Flash memory. Flash memory will be configured after the CR bit is set.

ODS bit

The output driver strength (ODS1, ODS0) bits are volatile bits, which indicate the output driver level (as defined in ["Table 9. Output Driver Strength Table"](#)) of the device. The Output Driver Strength is defaulted as 30 Ohms when delivered from factory. To write the ODS bits requires the Write Status Register (WRSR) instruction to be executed.

TB bit

The Top/Bottom (TB) bit is a non-volatile OTP bit. The Top/Bottom (TB) bit is used to configure the Block Protect area by BP bit (BP3, BP2, BP1, BP0), starting from TOP or Bottom of the memory array. The TB bit is defaulted as "0", which means Top area protect. When it is set as "1", the protect area will change to Bottom area of the memory device. To write the TB bits requires the Write Status Register (WRSR) instruction to be executed.

PBE bit

The Preamble Bit Enable (PBE) bit is a volatile bit. It is used to enable or disable the preamble bit data pattern output on dummy cycles. The PBE bit is defaulted as "0", which means preamble bit is disabled. When it is set as "1", the preamble bit will be enabled, and inputted into dummy cycles. To write the PBE bits requires the Write Status Register (WRSR) instruction to be executed.

4BYTE Indicator bit

By writing EN4B instruction, the 4BYTE bit may be set as "1" to access the address length of 32-bit for memory area of higher density (large than 128Mb). The default state is "0" as the 24-bit address mode. The 4BYTE bit may be cleared by power-off or writing EX4B instruction to reset the state to be "0".

Table 8. Configuration Register

bit7	bit6	bit5	bit4	bit3	bit2	bit1	bit0
DC1 (Dummy cycle 1)	DC0 (Dummy cycle 0)	4 BYTE	PBE (Preamble bit Enable)	TB (top/bottom selected)	Reserved	ODS 1 (output driver strength)	ODS 0 (output driver strength)
<i>(Note 2)</i>	<i>(Note 2)</i>	0=3-byte address mode 1=4-byte address mode (Default=0)	0=Disable 1=Enable	0=Top area protect 1=Bottom area protect (Default=0)	x	<i>(Note 1)</i>	<i>(Note 1)</i>
volatile bit	volatile bit	volatile bit	volatile bit	OTP	x	volatile bit	volatile bit

Note 1: Please refer to ["Table 9. Output Driver Strength Table"](#)

Note 2: Please refer to ["Table 10. Dummy Cycle and Frequency Table \(MHz\)"](#)

Table 9. Output Driver Strength Table

ODS1	ODS0	Resistance (Ohm)	Note
0	0	30 Ohms (Default)	Impedance at VCC/2
0	1	45 Ohms	
1	0	90 Ohms	
1	1	15 Ohms	

Table 10. Dummy Cycle and Frequency Table (MHz)

(STR Mode)

DC[1:0]	Numbers of Dummy clock cycles	Fast Read	Dual Output Fast Read	Quad Output Fast Read
00 (default)	8	120/133R	120/133R	120/133R
01	8	120/133R	120/133R	120/133R
10	8	120/133R	120/133R	120/133R
11	8	120/133R	120/133R	120/133R

DC[1:0]	Numbers of Dummy clock cycles	Dual IO Fast Read
00 (default)	4	80
01	8	120/133R
10	4	80
11	8	120/133R

DC[1:0]	Numbers of Dummy clock cycles	Quad IO Fast Read
00 (default)	6	80
01	4	54
10	8	84/104R
11	10	120/133R

(DTR Mode)

DC[1:0]	Numbers of Dummy clock cycles	Quad IO DTR Read
00 (default)	6	54
01	6	54
10	8	70/80R
11	10	84/100R

Note: "R" mean VCC range= 3.0V-3.6V.

9-10. Write Status Register (WRSR)

The WRSR instruction is for changing the values of Status Register Bits and Configuration Register Bits. Before sending WRSR instruction, the Write Enable (WREN) instruction must be decoded and executed to set the Write Enable Latch (WEL) bit in advance. The WRSR instruction can change the value of Block Protect (BP3, BP2, BP1, BP0) bits to define the protected area of memory (as shown in [Table 2](#)), but has no effect on bit1(WEL) and bit0 (WIP) of the status register.

The sequence of issuing WRSR instruction is: CS# goes low→ sending WRSR instruction code→ Status Register data on SI→CS# goes high.

The CS# must go high exactly at the 8 bits or 16 bits data boundary; otherwise, the instruction will be rejected and not executed. The self-timed Write Status Register cycle time (tW) is initiated as soon as Chip Select (CS#) goes high. The Write in Progress (WIP) bit still can be check out during the Write Status Register cycle is in progress. The WIP sets 1 during the tW timing, and sets 0 when Write Status Register Cycle is completed, and the Write Enable Latch (WEL) bit is reset.

Figure 27. Write Status Register (WRSR) Sequence (SPI Mode)

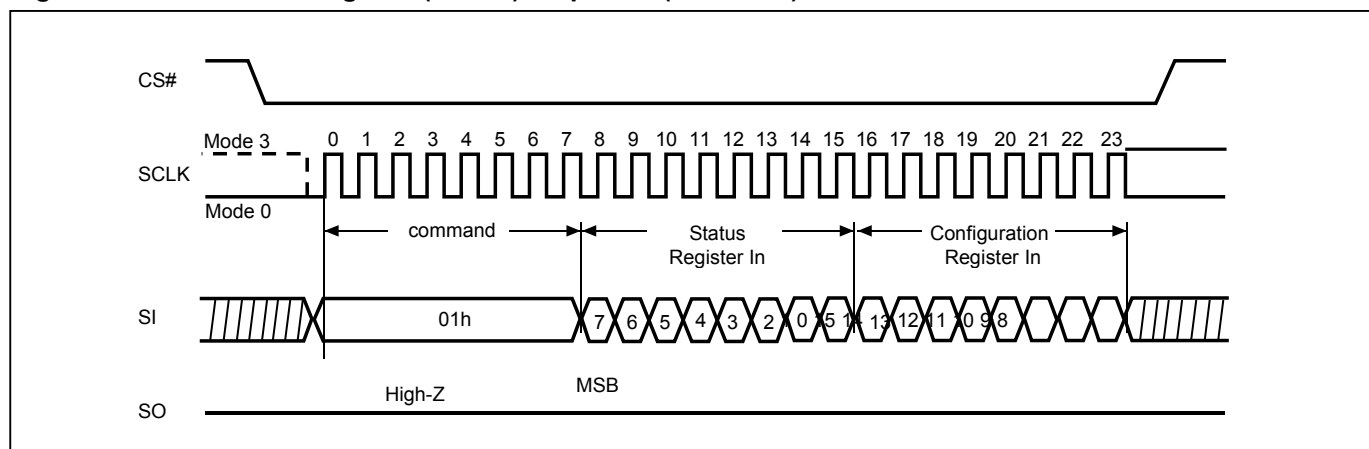

Note: The CS# must go high exactly at 8 bits or 16 bits data boundary to completed the write register command.

Figure 28. Write Status Register (WRSR) Sequence (QPI Mode)

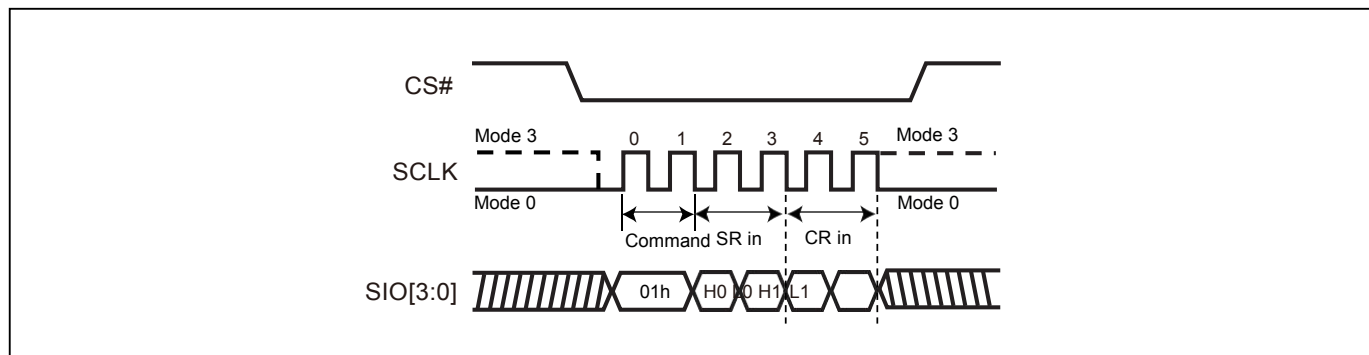

Software Protected Mode (SPM):

- The WREN instruction may set the WEL bit and can change the values of BP3, BP2, BP1, BP0. The protected area, which is defined by BP3, BP2, BP1, BP0 and T/B bit, is at software protected mode (SPM).

Table 11. Protection Modes

Mode	Status register condition	Memory
Software protection mode (SPM)	Status register can be written in (WEL bit is set to "1") and the BP0-BP3 bits can be changed	The protected area cannot be programmed or erased.

Note:

1. As defined by the values in the Block Protect (BP3, BP2, BP1, BP0) bits of the Status Register, as shown in ["Table 2. Protected Area Sizes"](#).

Figure 29. WRSR flow

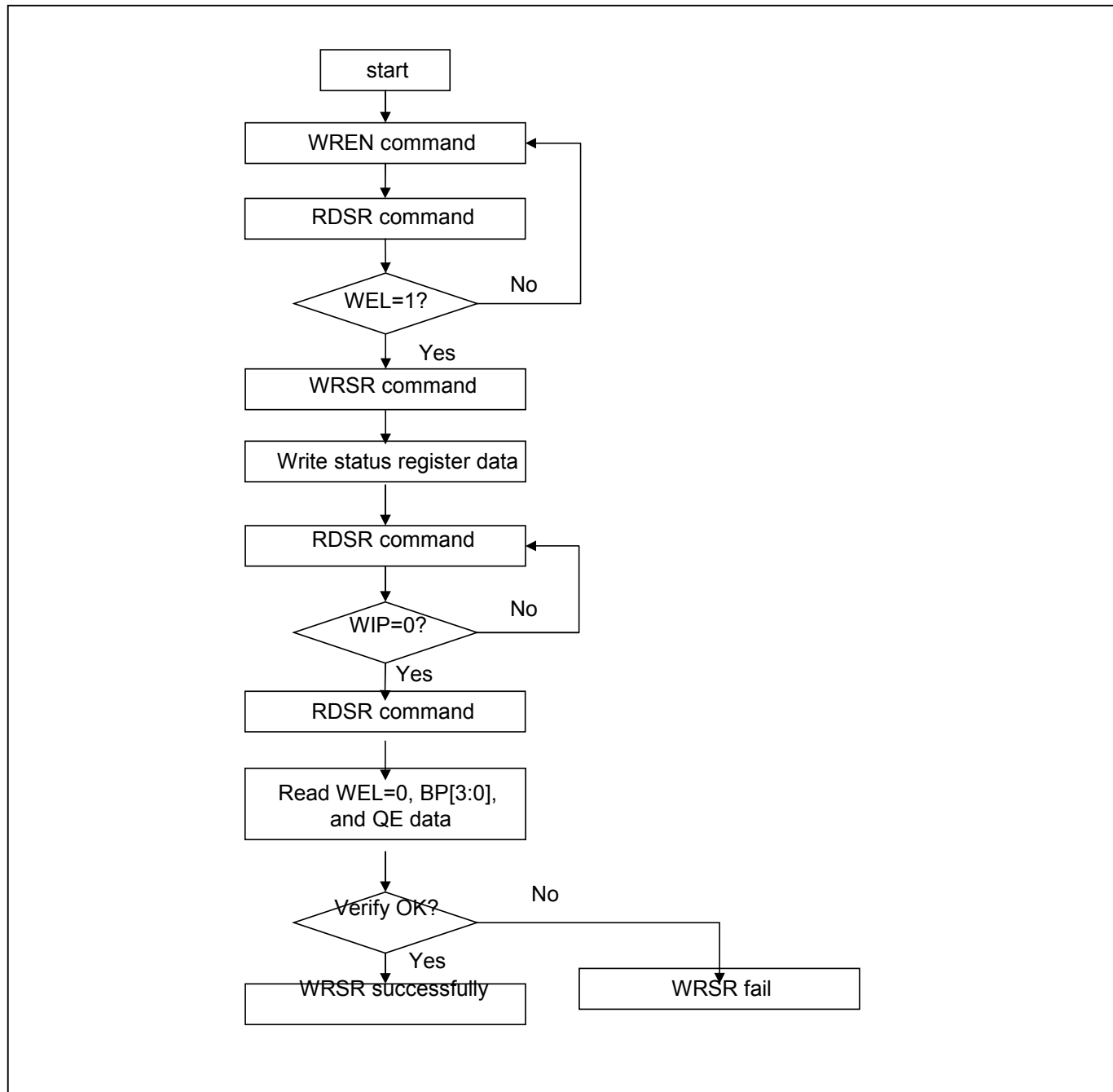

9-11. Enter 4-byte mode (EN4B)

The EN4B instruction enables accessing the address length of 32-bit for the memory area of higher density (larger than 128Mb). The device default is in 24-bit address mode; after sending out the EN4B instruction, the bit5 (4BYTE bit) of Configuration Register will be automatically set to "1" to indicate the 4-byte address mode has been enabled. Once the 4-byte address mode is enabled, the address length becomes 32-bit instead of the default 24-bit. There are three methods to exit the 4-byte mode: writing exit 4-byte mode (EX4B) instruction, Reset or power-off.

All instructions are accepted normally, and just the address bit is changed from 24-bit to 32-bit.

The following commands don't support 4-byte address: RDSFDP, RES and REMS.

The sequence of issuing EN4B instruction is: CS# goes low → sending EN4B instruction to enter 4-byte mode(automatically set 4BYTE bit as "1") → CS# goes high.

9-12. Exit 4-byte mode (EX4B)

The EX4B instruction is executed to exit the 4-byte address mode and return to the default 3-bytes address mode. After sending out the EX4B instruction, the bit5 (4BYTE bit) of Configuration Register will be cleared to be "0" to indicate the exit of the 4-byte address mode. Once exiting the 4-byte address mode, the address length will return to 24-bit.

The sequence of issuing EX4B instruction is: CS# goes low → sending EX4B instruction to exit 4-byte mode (automatically clear the 4BYTE bit to be "0") → CS# goes high.

9-13. Read Data Bytes (READ)

The read instruction is for reading data out. The address is latched on rising edge of SCLK, and data shifts out on the falling edge of SCLK at a maximum frequency f_R . The first address byte can be at any location. The address is automatically increased to the next higher address after each byte data is shifted out, so the whole memory can be read out at a single READ instruction. The address counter rolls over to 0 when the highest address has been reached.

The default read mode is 3-byte address, to access higher address (4-byte address) which requires to enter the 4-byte address read mode or to define EAR bit. To enter the 4-byte mode, please refer to the "9-11. Enter 4-byte mode (EN4B)" section.

The sequence of issuing READ instruction is: CS# goes low→sending READ instruction code→ 3-byte or 4-byte address on SI→ data out on SO→to end READ operation can use CS# to high at any time during data out.

Figure 30. Read Data Bytes (READ) Sequence (SPI Mode only)

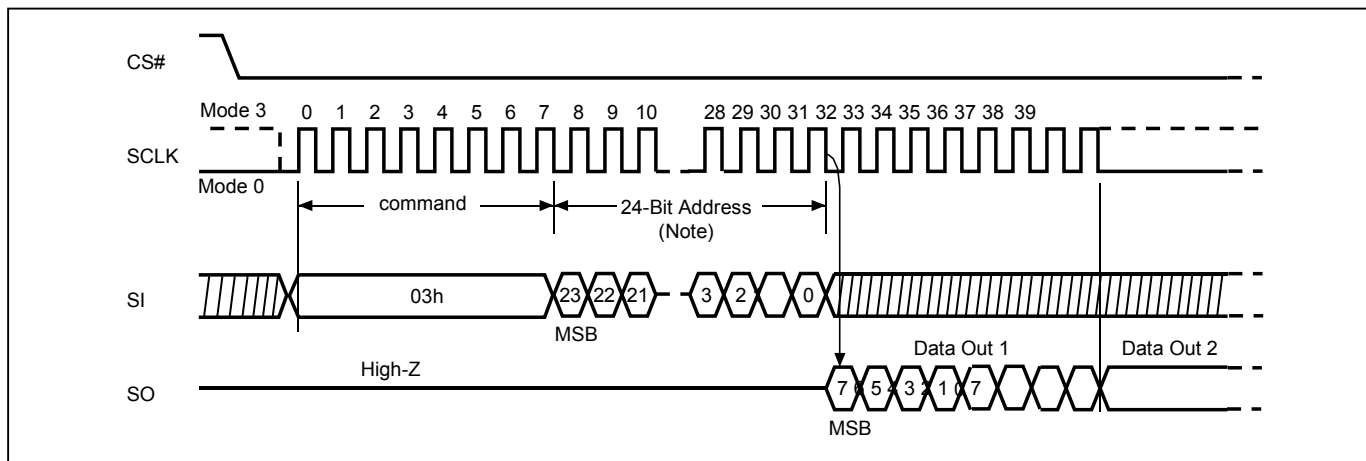

Note: Please note the address cycles above are based on 3-byte address mode. For 4-byte address mode, the address cycles will be increased.



9-14. Read Data Bytes at Higher Speed (FAST_READ)

The FAST_READ instruction is for quickly reading data out. The address is latched on rising edge of SCLK, and data of each bit shifts out on the falling edge of SCLK at a maximum frequency fC. The first address byte can be at any location. The address is automatically increased to the next higher address after each byte data is shifted out, so the whole memory can be read out at a single FAST_READ instruction. The address counter rolls over to 0 when the highest address has been reached.

The default read mode is 3-byte address, to access higher address (4-byte address) which requires to enter the 4-byte address read mode or to define EAR bit. To enter the 4-byte mode, please refer to the ["9-11. Enter 4-byte mode \(EN4B\)"](#) section.

Read on SPI Mode The sequence of issuing FAST_READ instruction is: CS# goes low→ sending FAST_READ instruction code→ 3-byte or 4-byte address on SI→ 8 dummy cycles (default)→ data out on SO→ to end FAST_READ operation can use CS# to high at any time during data out.

While Program/Erase/Write Status Register cycle is in progress, FAST_READ instruction is rejected without any impact on the Program/Erase/Write Status Register current cycle.

Figure 31. Read at Higher Speed (FAST_READ) Sequence (SPI Mode)

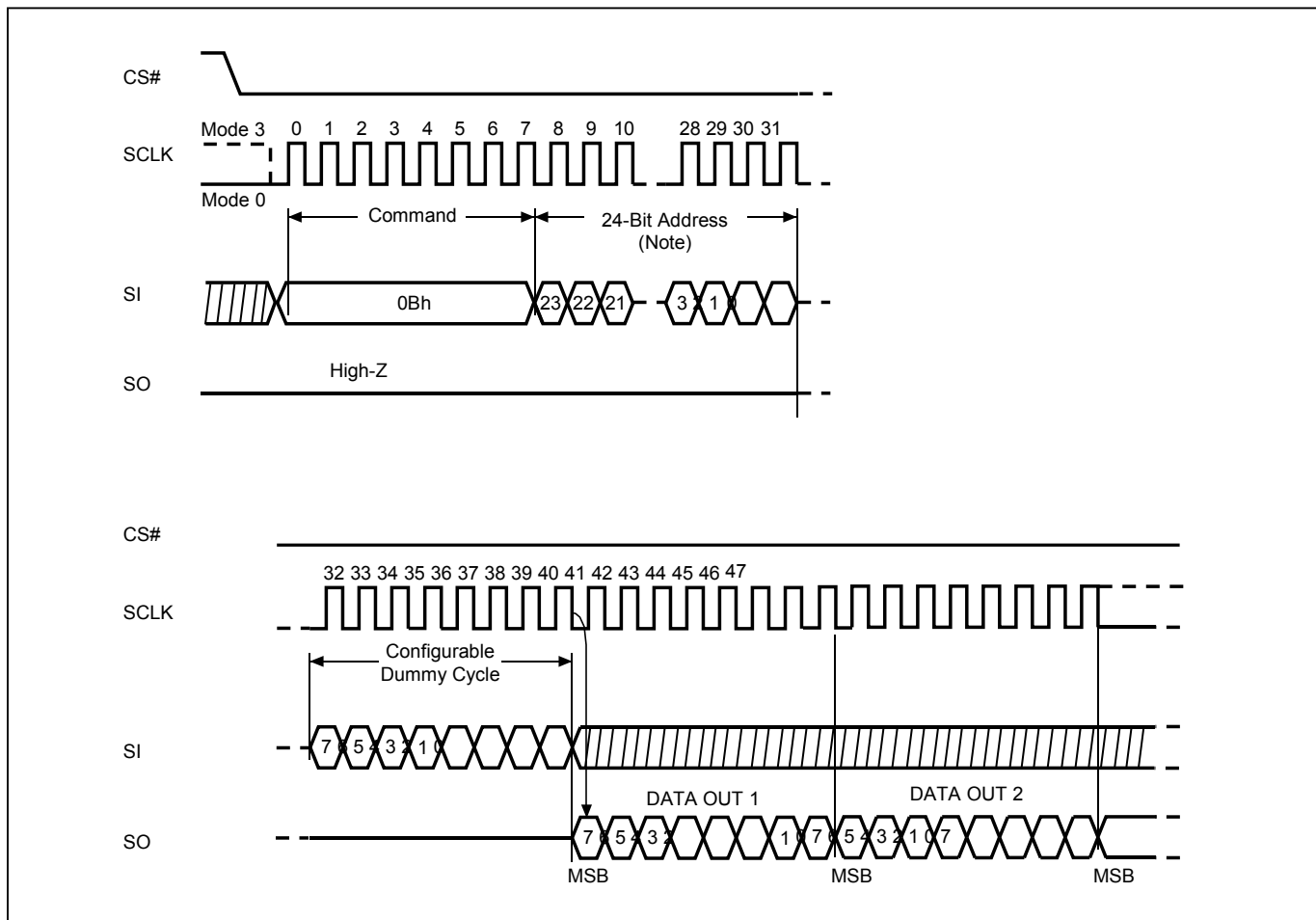

Note: Please note the address cycles above are based on 3-byte address mode. For 4-byte address mode, the address cycles will be increased.

9-15. Dual Output Read Mode (DREAD)

The DREAD instruction enable double throughput of Serial NOR Flash in read mode. The address is latched on rising edge of SCLK, and data of every two bits (interleave on 2 I/O pins) shift out on the falling edge of SCLK at a maximum frequency f_T . The first address byte can be at any location. The address is automatically increased to the next higher address after each byte data is shifted out, so the whole memory can be read out at a single DREAD instruction. The address counter rolls over to 0 when the highest address has been reached. Once writing DREAD instruction, the following data out will perform as 2-bit instead of previous 1-bit.

The default read mode is 3-byte address, to access higher address (4-byte address) which requires to enter the 4-byte address read mode or to define EAR bit. To enter the 4-byte mode, please refer to the "9-11. Enter 4-byte mode (EN4B)" section.

The sequence of issuing DREAD instruction is: CS# goes low → sending DREAD instruction → 3-byte or 4-byte address on SIO0 → 8 dummy cycles (default) on SIO0 → data out interleave on SIO1 & SIO0 → to end DREAD operation can use CS# to high at any time during data out.

While Program/Erase/Write Status Register cycle is in progress, DREAD instruction is rejected without any impact on the Program/Erase/Write Status Register current cycle.

Figure 32. Dual Read Mode Sequence

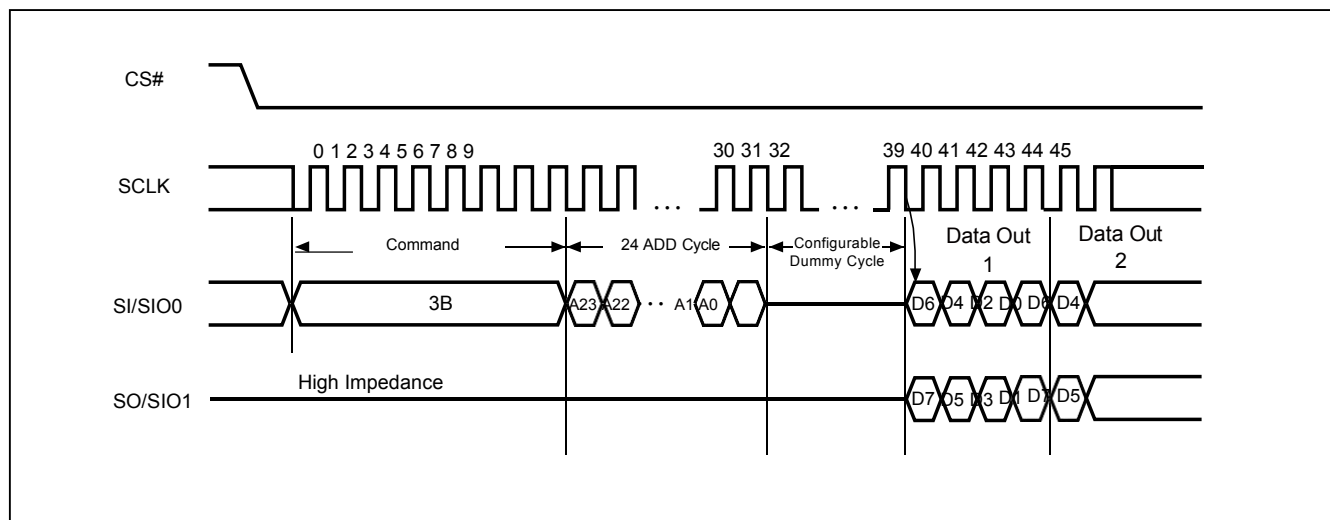

Notes:

1. Please note the above address cycles are base on 3-byte address mode, for 4-byte address mode, the address cycles will be increased.

9-16. 2 x I/O Read Mode (2READ)

The 2READ instruction enable double throughput of Serial NOR Flash in read mode. The address is latched on rising edge of SCLK, and data of every two bits (interleave on 2 I/O pins) shift out on the falling edge of SCLK at a maximum frequency f_T . The first address byte can be at any location. The address is automatically increased to the next higher address after each byte data is shifted out, so the whole memory can be read out at a single 2READ instruction. The address counter rolls over to 0 when the highest address has been reached. Once writing 2READ instruction, the following address/dummy/data out will perform as 2-bit instead of previous 1-bit.

The default read mode is 3-byte address, to access higher address (4-byte address) which requires to enter the 4-byte address read mode or to define EAR bit. To enter the 4-byte mode, please refer to the enter 4-byte mode (EN4B) Mode section.

The sequence of issuing 2READ instruction is: CS# goes low→ sending 2READ instruction→ 3-byte or 4-byte address interleave on SIO1 & SIO0→ 4 dummy cycles (default) on SIO1 & SIO0→ data out interleave on SIO1 & SIO0→ to end 2READ operation can use CS# to high at any time during data out.

While Program/Erase/Write Status Register cycle is in progress, 2READ instruction is rejected without any impact on the Program/Erase/Write Status Register current cycle.

Figure 33. 2 x I/O Read Mode Sequence (SPI Mode only)

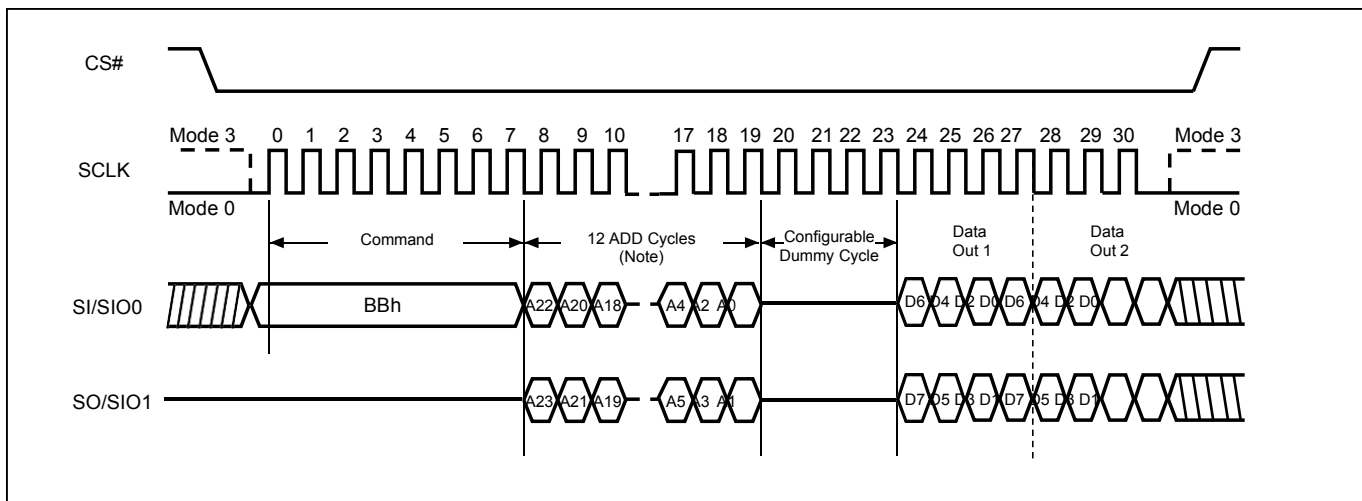

Note: Please note the address cycles above are based on 3-byte address mode. For 4-byte address mode, the address cycles will be increased.

9-17. Quad Read Mode (QREAD)

The QREAD instruction enable quad throughput of Serial NOR Flash in read mode. The address is latched on rising edge of SCLK, and data of every four bits (interleave on 4 I/O pins) shift out on the falling edge of SCLK at a maximum frequency fQ. The first address byte can be at any location. The address is automatically increased to the next higher address after each byte data is shifted out, so the whole memory can be read out at a single QREAD instruction. The address counter rolls over to 0 when the highest address has been reached. Once writing QREAD instruction, the following data out will perform as 4-bit instead of previous 1-bit.

The default read mode is 3-byte address, to access higher address (4-byte address) which requires to enter the 4-byte address read mode or to define EAR bit. To enter the 4-byte mode, please refer to the enter 4-byte mode (EN4B) Mode section.

The sequence of issuing QREAD instruction is: CS# goes low → sending QREAD instruction → 3-byte or 4-byte address on SI → 8 dummy cycle (Default) → data out interleave on SIO3, SIO2, SIO1 & SIO0 → to end QREAD operation can use CS# to high at any time during data out.

While Program/Erase/Write Status Register cycle is in progress, QREAD instruction is rejected without any impact on the Program/Erase/Write Status Register current cycle.

Figure 34. Quad Read Mode Sequence

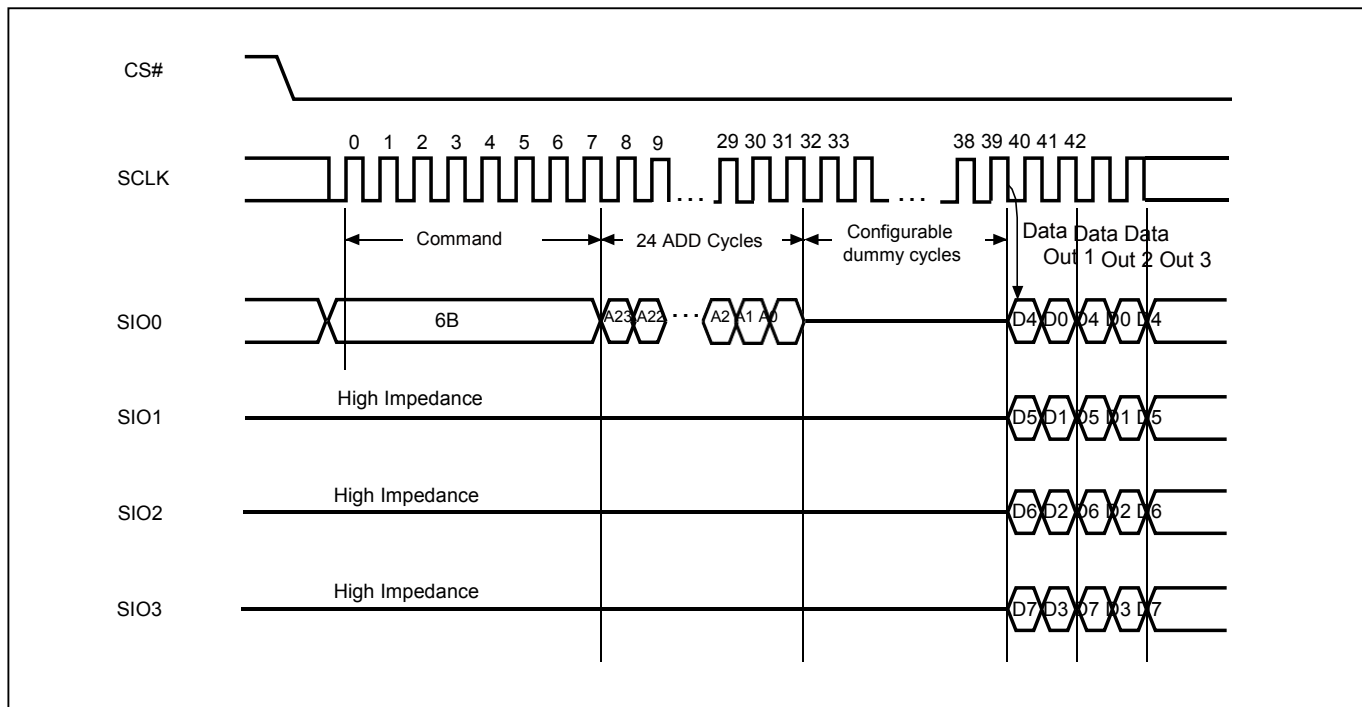

Notes:

1. Please note the above address cycles are base on 3-byte address mode, for 4-byte address mode, the address cycles will be increased.

9-18. 4 x I/O Read Mode (4READ)

The 4READ instruction enable quad throughput of Serial NOR Flash in read mode. The address is latched on rising edge of SCLK, and data of every four bits (interleave on 4 I/O pins) shift out on the falling edge of SCLK at a maximum frequency fQ. The first address byte can be at any location. The address is automatically increased to the next higher address after each byte data is shifted out, so the whole memory can be read out at a single 4READ instruction. The address counter rolls over to 0 when the highest address has been reached. Once writing 4READ instruction, the following address/dummy/data out will perform as 4-bit instead of previous 1-bit.

The default read mode is 3-byte address, to access higher address (4-byte address) which requires to enter the 4-byte address read mode or to define EAR bit. To enter the 4-byte mode, please refer to the enter 4-byte mode (EN4B) Mode section.

4 x I/O Read on SPI Mode (4READ) The sequence of issuing 4READ instruction is: CS# goes low→ sending 4READ instruction→ 3-byte or 4-byte address interleave on SIO3, SIO2, SIO1 & SIO0→ 6 dummy cycles (Default) →data out interleave on SIO3, SIO2, SIO1 & SIO0→ to end 4READ operation can use CS# to high at any time during data out.

4 x I/O Read on QPI Mode (4READ) The 4READ instruction also support on QPI command mode. The sequence of issuing 4READ instruction QPI mode is: CS# goes low→ sending 4READ instruction→ 3-byte or 4-byte address interleave on SIO3, SIO2, SIO1 & SIO0→ 6 dummy cycles (Default) →data out interleave on SIO3, SIO2, SIO1 & SIO0→ to end 4READ operation can use CS# to high at any time during data out.

While Program/Erase/Write Status Register cycle is in progress, 4READ instruction is rejected without any impact on the Program/Erase/Write Status Register current cycle.

Figure 35. 4 x I/O Read Mode Sequence (SPI Mode)

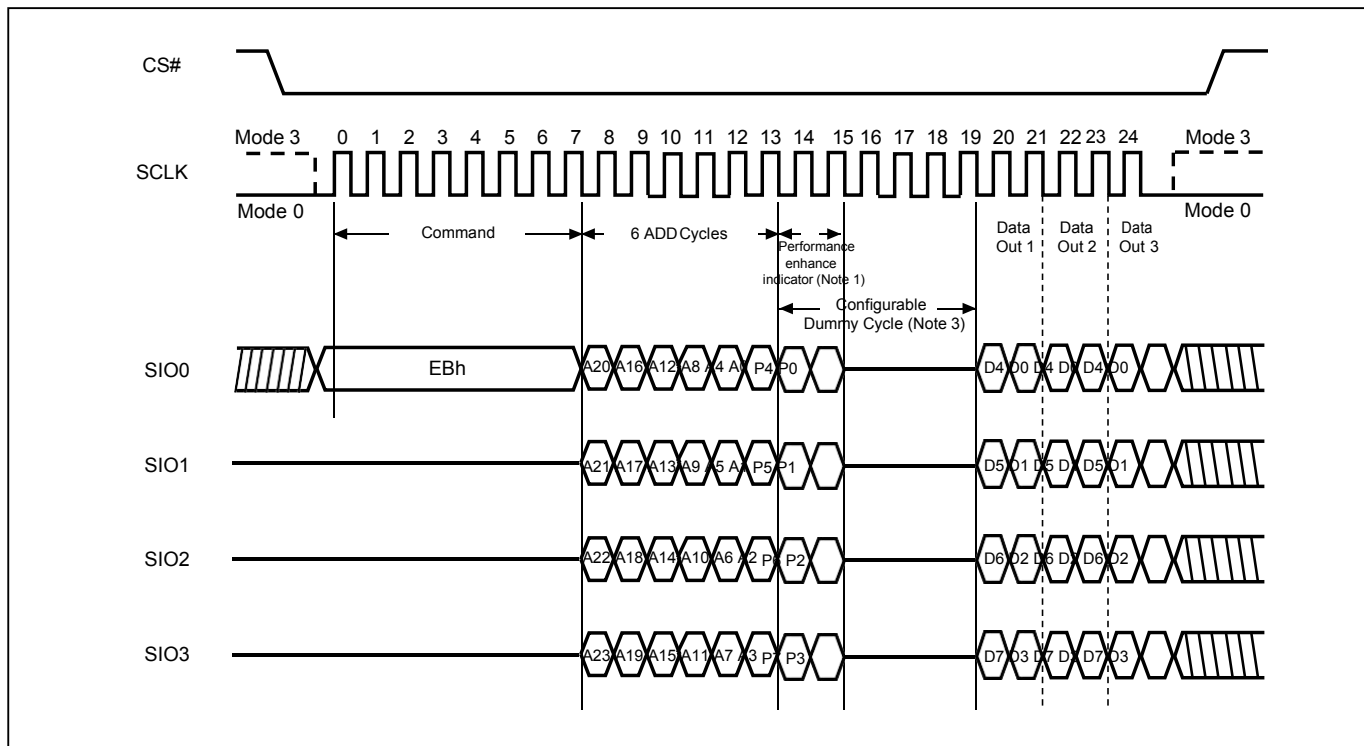

Notes:

1. Hi-impedance is inhibited for the two clock cycles.
2. P7≠P3, P6≠P2, P5≠P1 & P4≠P0 (Toggling) is inhibited.
3. Configuration Dummy cycle numbers will be different depending on the bit6 & bit 7 (DC0 & DC1) setting in configuration register.
4. Please note the address cycles above are based on 3-byte address mode. For 4-byte address mode, the address cycles will be increased.

Figure 36. 4 x I/O Read Mode Sequence (QPI Mode)

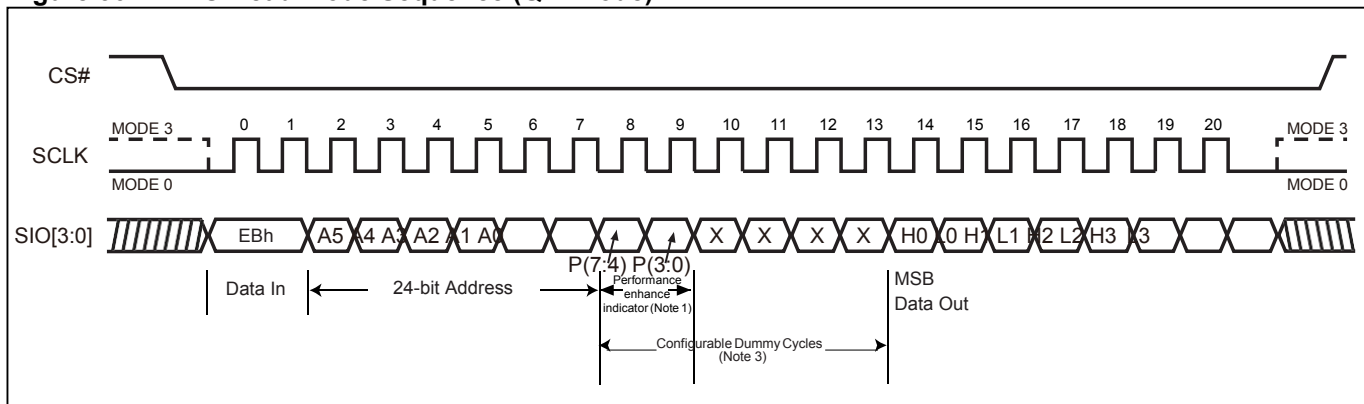

Notes:

1. Hi-impedance is inhibited for the two clock cycles.
2. P7≠P3, P6≠P2, P5≠P1 & P4≠P0 (Toggling) is inhibited.
3. Configuration Dummy cycle numbers will be different depending on the bit6 & bit 7 (DC0 & DC1) setting in configuration register.
4. Please note the address cycles above are based on 3-byte address mode. For 4-byte address mode, the address cycles will be increased.



9-19. 4 x I/O Double Transfer Rate Read Mode (4DTRD)

The 4DTRD instruction enables Double Transfer Rate throughput on quad I/O of Serial NOR Flash in read mode. A Quad Enable (QE) bit of status Register must be set to "1" before sending the 4DTRD instruction. The address (interleave on 4 I/O pins) is latched on both rising and falling edge of SCLK, and data (interleave on 4 I/O pins) shift out on both rising and falling edge of SCLK. The 8-bit address can be latched-in at one clock, and 8-bit data can be read out at one clock, which means four bits at rising edge of clock, the other four bits at falling edge of clock. The first address byte can be at any location. The address is automatically increased to the next higher address after each byte data is shifted out, so the whole memory can be read out at a single 4DTRD instruction. The address counter rolls over to 0 when the highest address has been reached. Once writing 4DTRD instruction, the following address/dummy/data out will perform as 8-bit instead of previous 1-bit.

Both SPI (8 clocks) and QPI (2 clocks) command cycle can accept by this instruction. The SIO[3:1] are don't care when during SPI mode.

While Program/Erase/Write Status Register cycle is in progress, 4DTRD instruction is rejected without any impact on the Program/Erase/Write Status Register current cycle.

Figure 37. Fast Quad I/O DT Read (4DTRD) Sequence (SPI Mode)

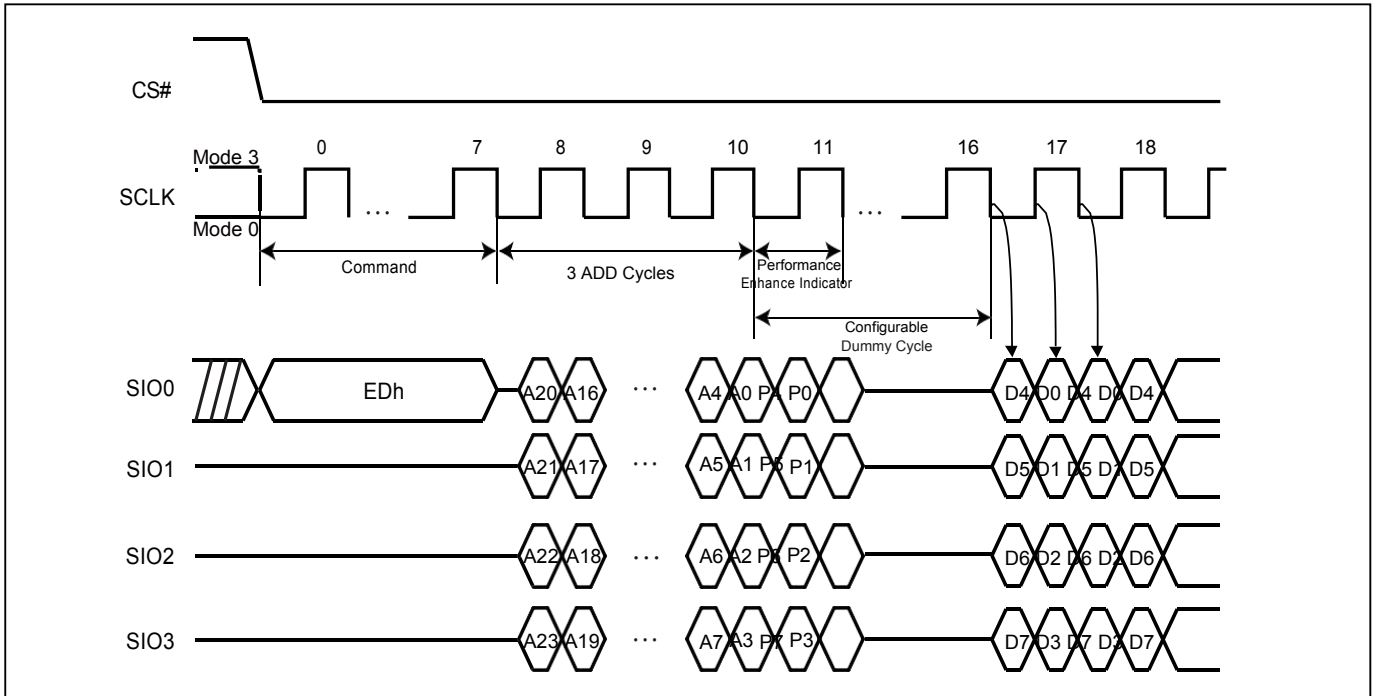

Notes:

1. Hi-impedance is inhibited for this clock cycle.
2. P7≠P3, P6≠P2, P5≠P1 & P4≠P0 (Toggling) will result in entering the performance enhance mode.
3. Configuration Dummy cycle numbers will be different depending on the bit6 & bit 7 (DC0 & DC1) setting in configuration register.
4. Please note the address cycles above are based on 3-byte address mode. For 4-byte address mode, the address cycles will be increased.

Figure 38. Fast Quad I/O DT Read (4DTRD) Sequence (QPI Mode)

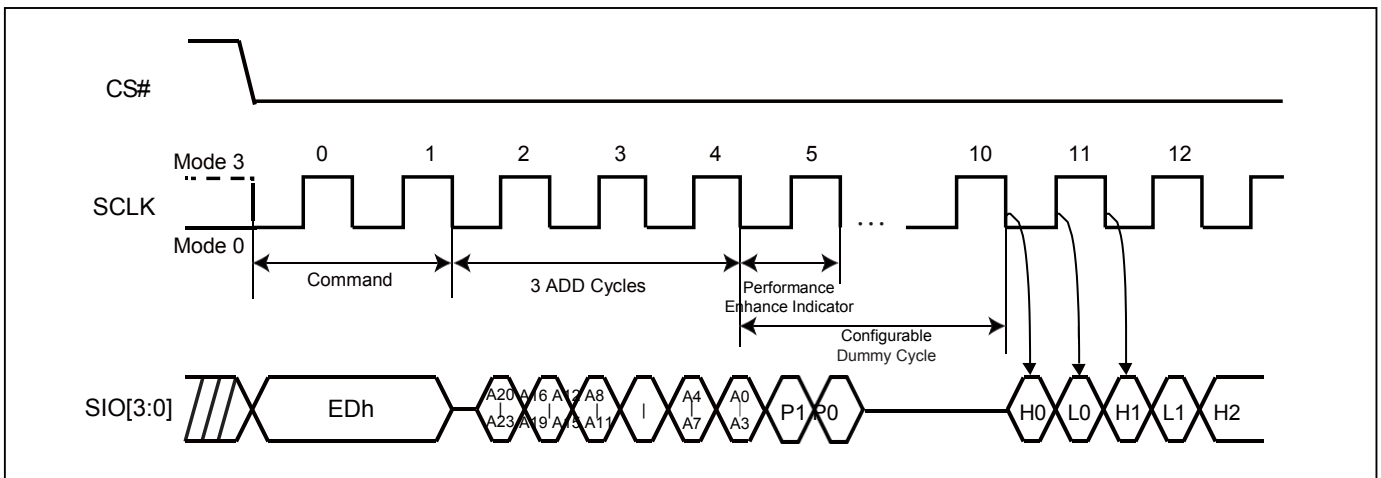

Notes:

1. Please note the address cycles above are based on 3-byte address mode. For 4-byte address mode, the address cycles will be increased.
2. Configuration Dummy cycle numbers will be different depending on the bit6 & bit 7 (DC0 & DC1) setting in configuration register.

9-20. Preamble Bit

The Preamble Bit data pattern supports system/memory controller to determine valid window of data output more easily and improve data capture reliability while the flash memory is running in high frequency.

Preamble Bit data pattern can be enabled or disabled by setting the bit4 of Configuration register (Preamble bit Enable bit). Once the CR<4> is set, the preamble bit is inputted into dummy cycles.

Enabling preamble bit will not affect the function of enhance mode bit. In Dummy cycles, performance enhance mode bit still operates with the same function. Preamble bit will output after performance enhance mode bit.

The preamble bit is a fixed 8-bit data pattern (00110100). While dummy cycle number reaches 10, the complete 8 bits will start to output right after the performance enhance mode bit. While dummy cycle is not sufficient of 10 cycles, the rest of the preamble bits will be cut. For example, 8 dummy cycles will cause 6 preamble bits to output, and 6 dummy cycles will cause 4 preamble bits to output.

Figure 39. SDR 1I/O (10DC)

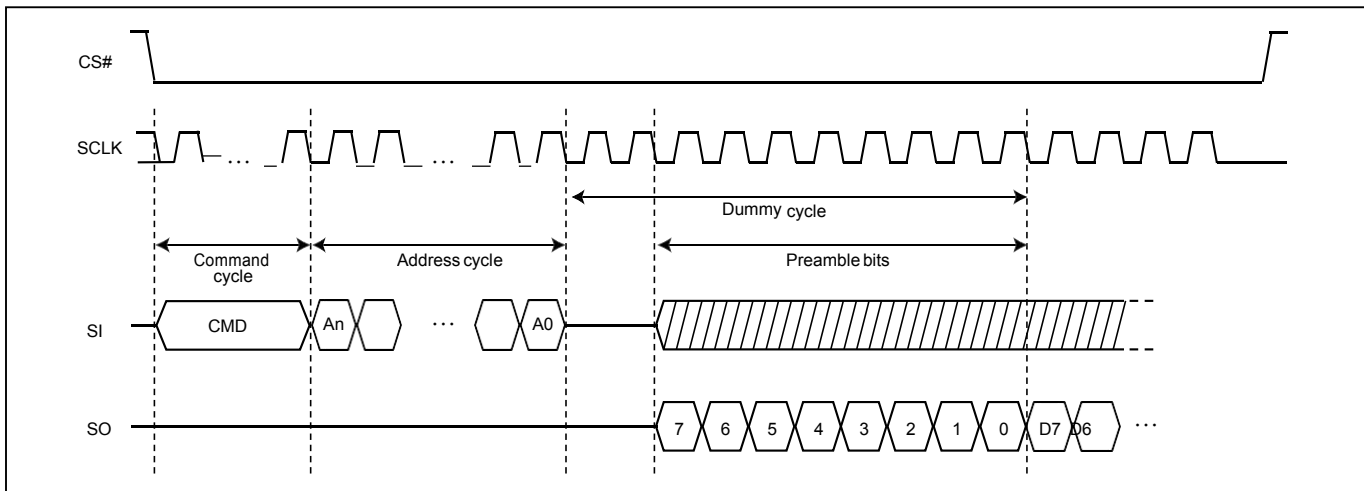

Figure 40. SDR 1I/O (8DC)

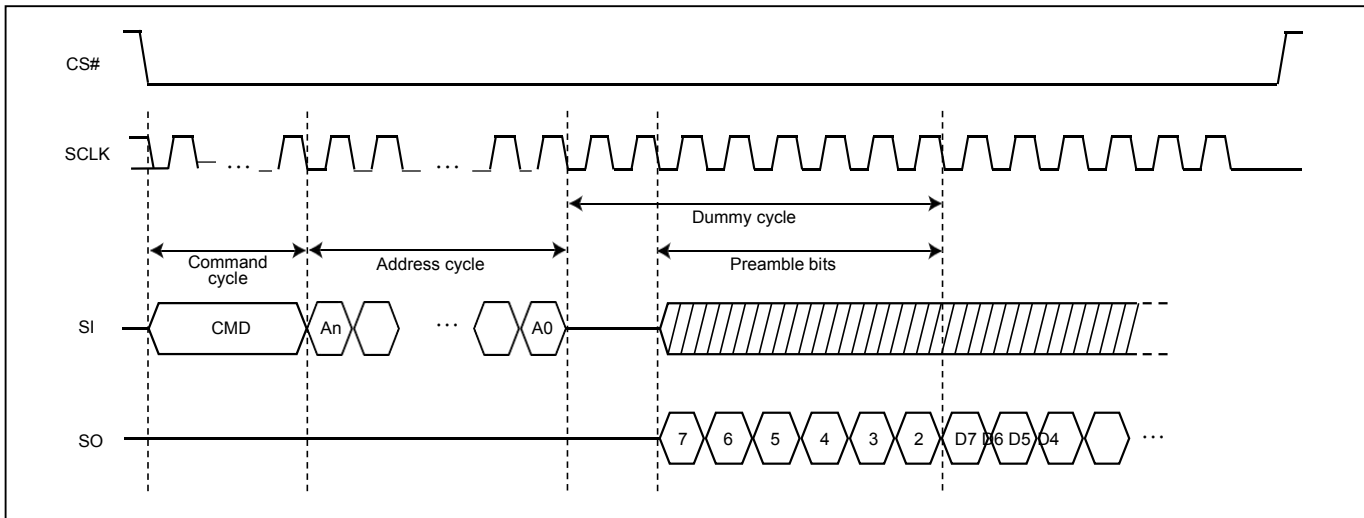

Figure 41. SDR 2I/O (10DC)

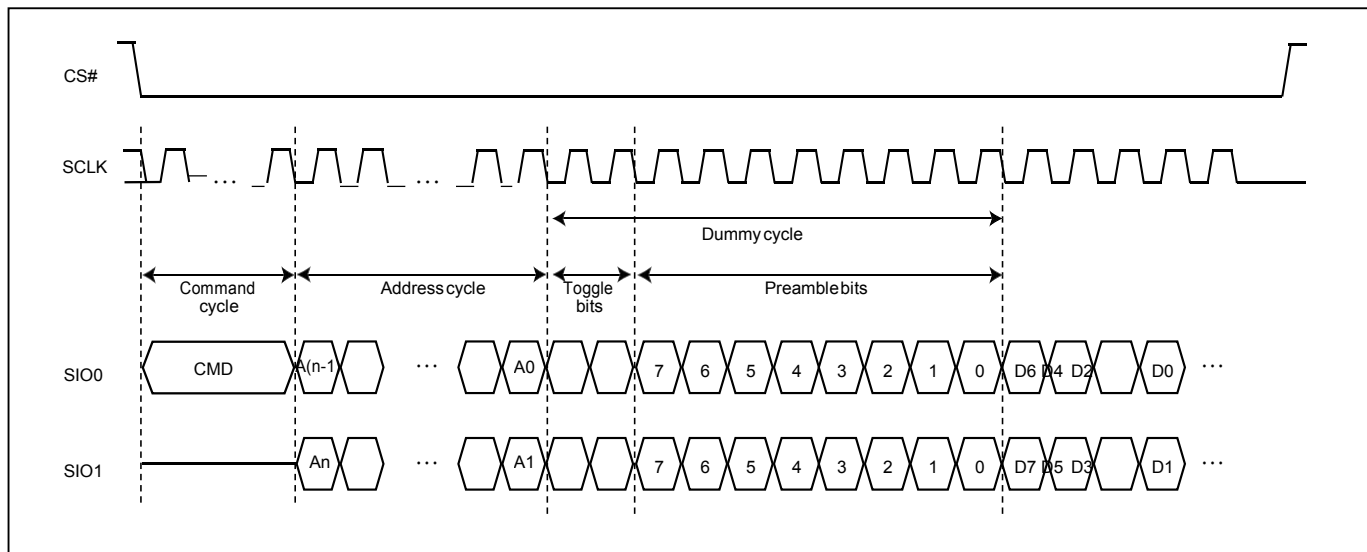

Figure 42. SDR 2I/O (8DC)

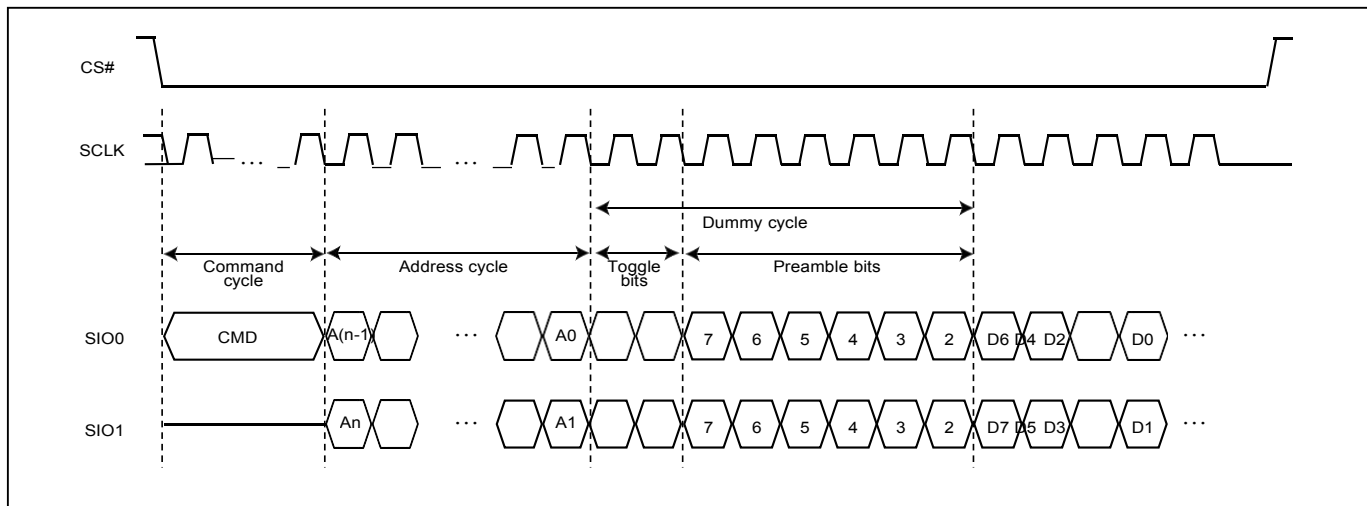

Figure 43. SDR 4I/O (10DC)

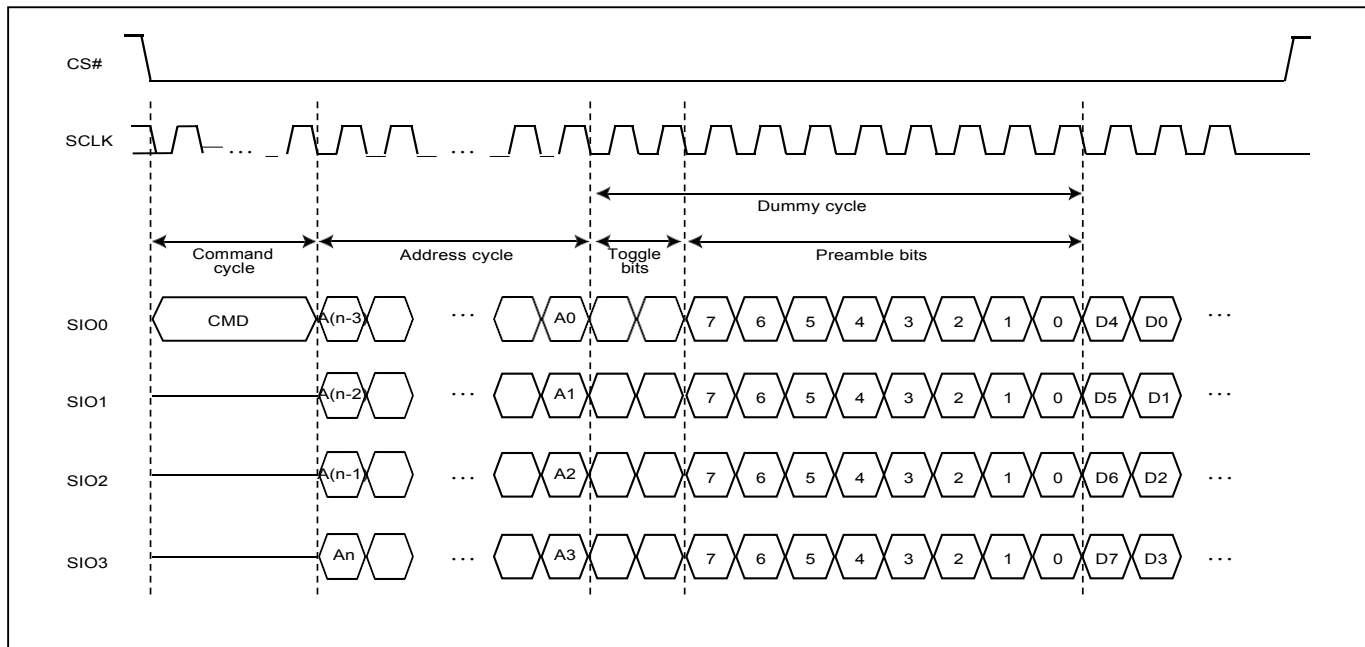

Figure 44. SDR 4I/O (8DC)

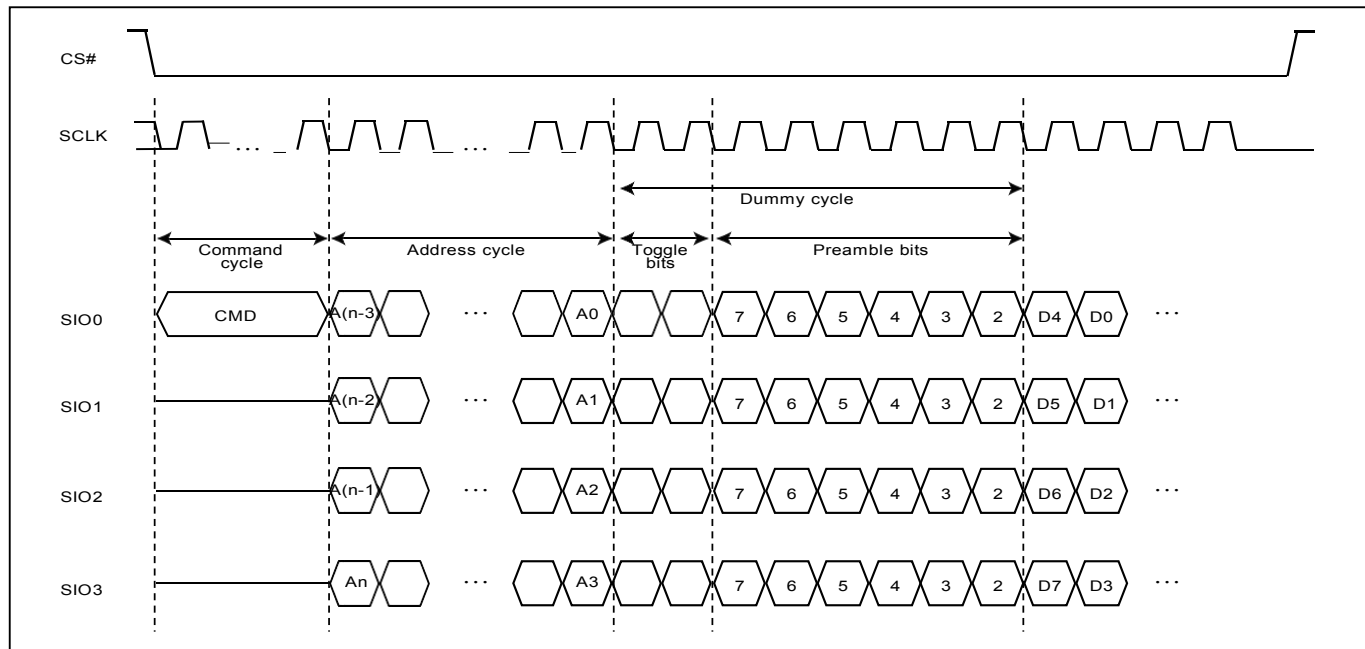
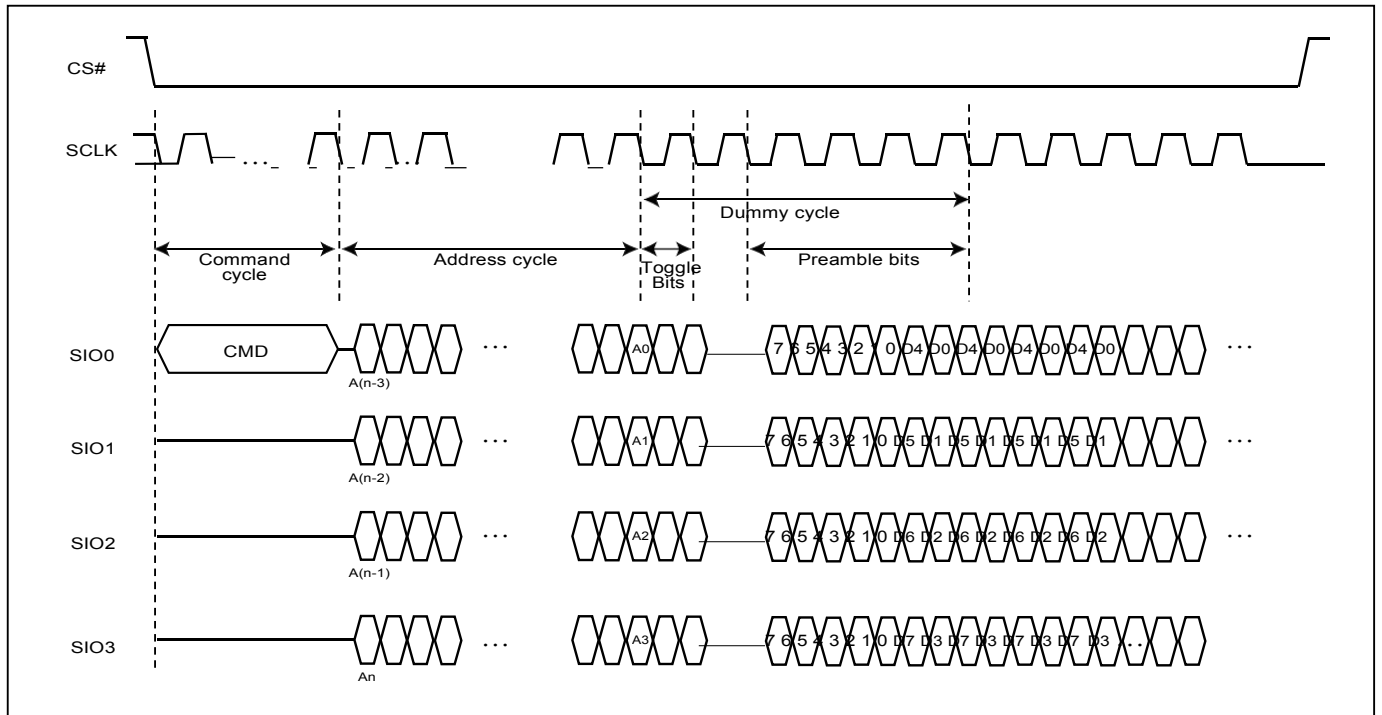

Figure 45. DTR4IO (6DC)



9-21. 4 Byte Address Command Set

The operation of 4-byte address command set was very similar to original 3-byte address command set. The only different is all the 4-byte command set request 4-byte address (A31-A0) followed by instruction code. The command set support 4-byte address including: READ4B, Fast_Read4B, DREAD4B, 2READ4B, QREAD4B, 4READ4B, PP4B, 4PP4B, SE4B, BE32K4B, BE4B. Please note that it is not necessary to issue EN4B command before issuing any of 4-byte command set.

Figure 46. Read Data Bytes using 4 Byte Address Sequence (READ4B)

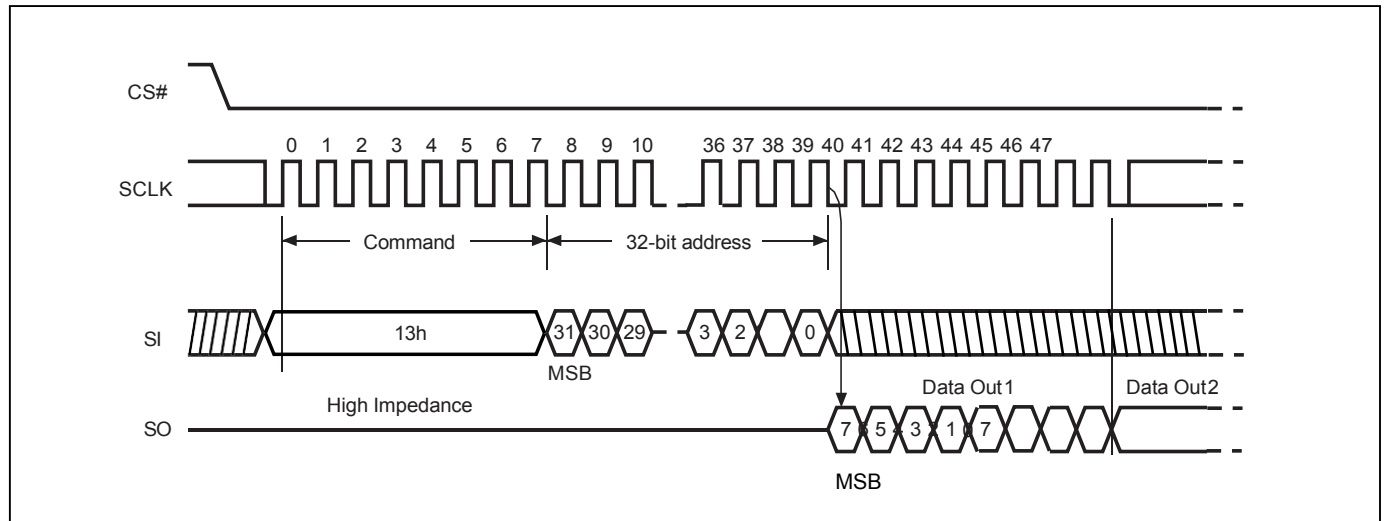

Figure 47. Read Data Bytes at Higher Speed using 4 Byte Address Sequence (FASTREAD4B)

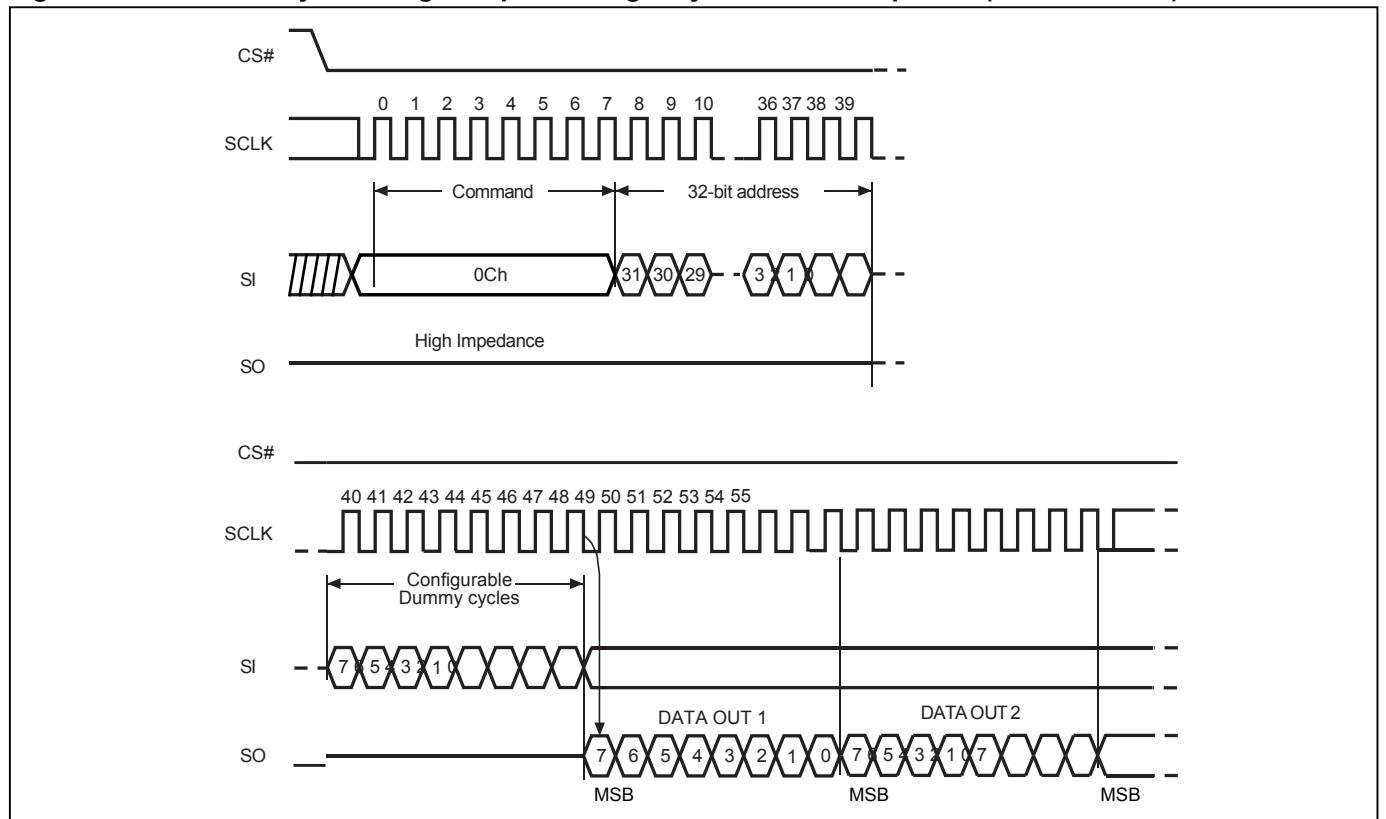

Figure 48. 2 x I/O Fast Read using 4 Byte Address Sequence (2READ4B)

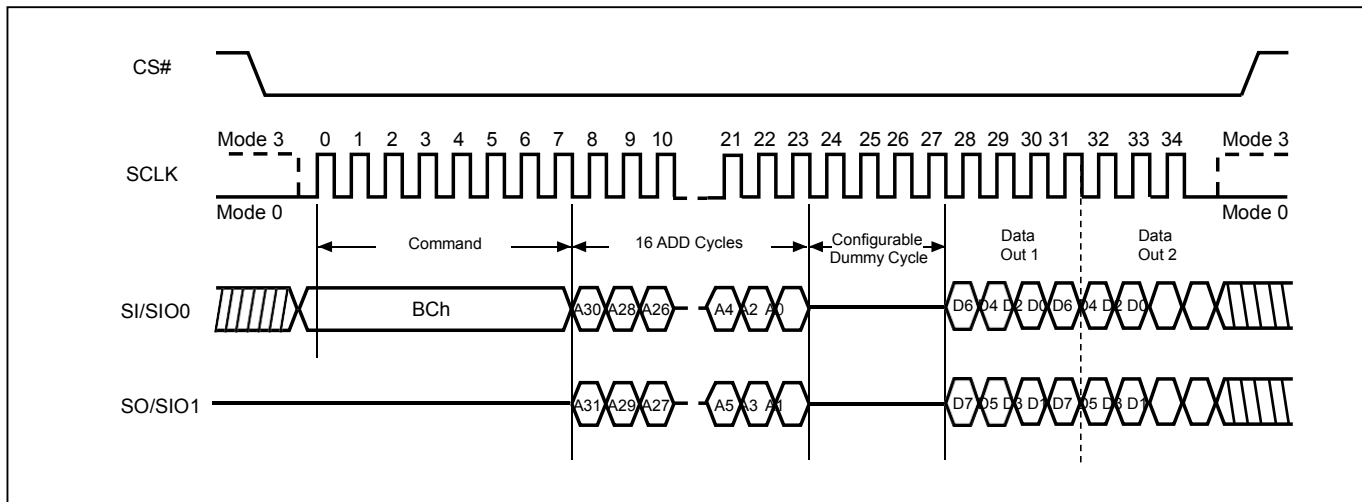

Figure 49. 4 I/O Fast Read using 4 Byte Address sequence (4READ4B)

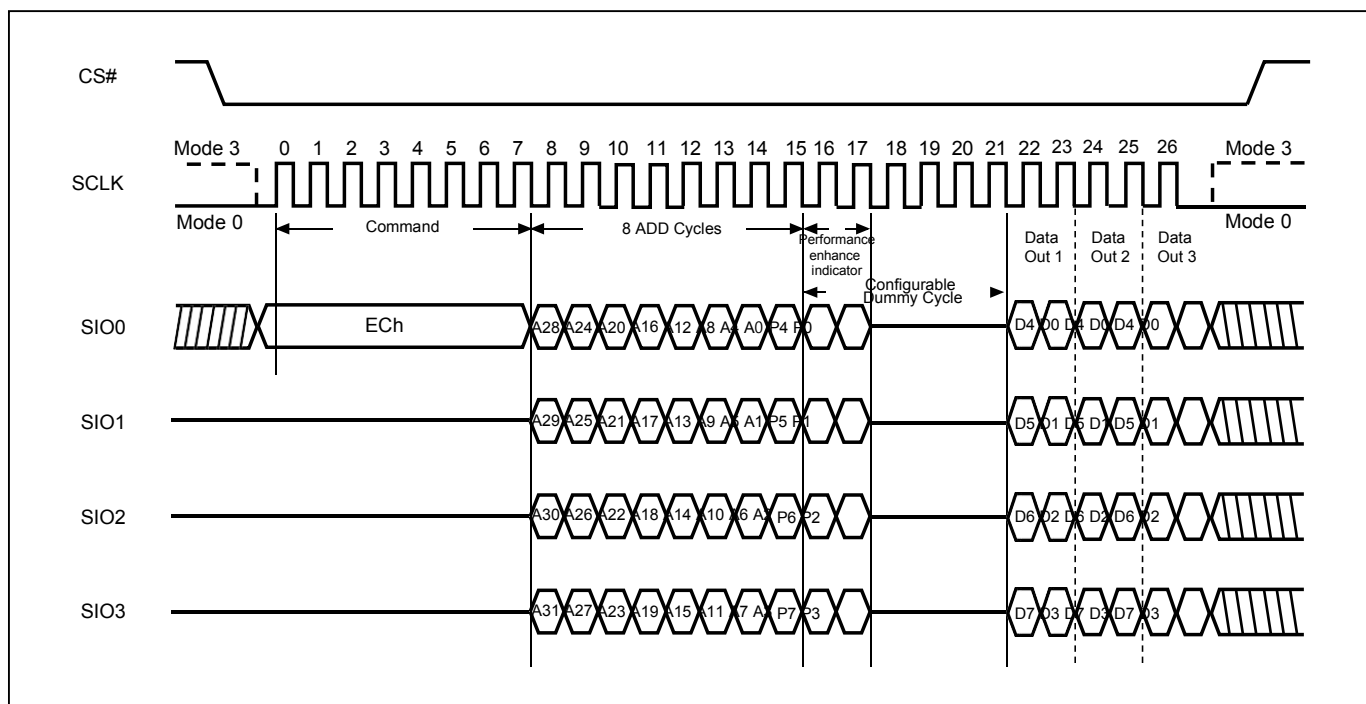
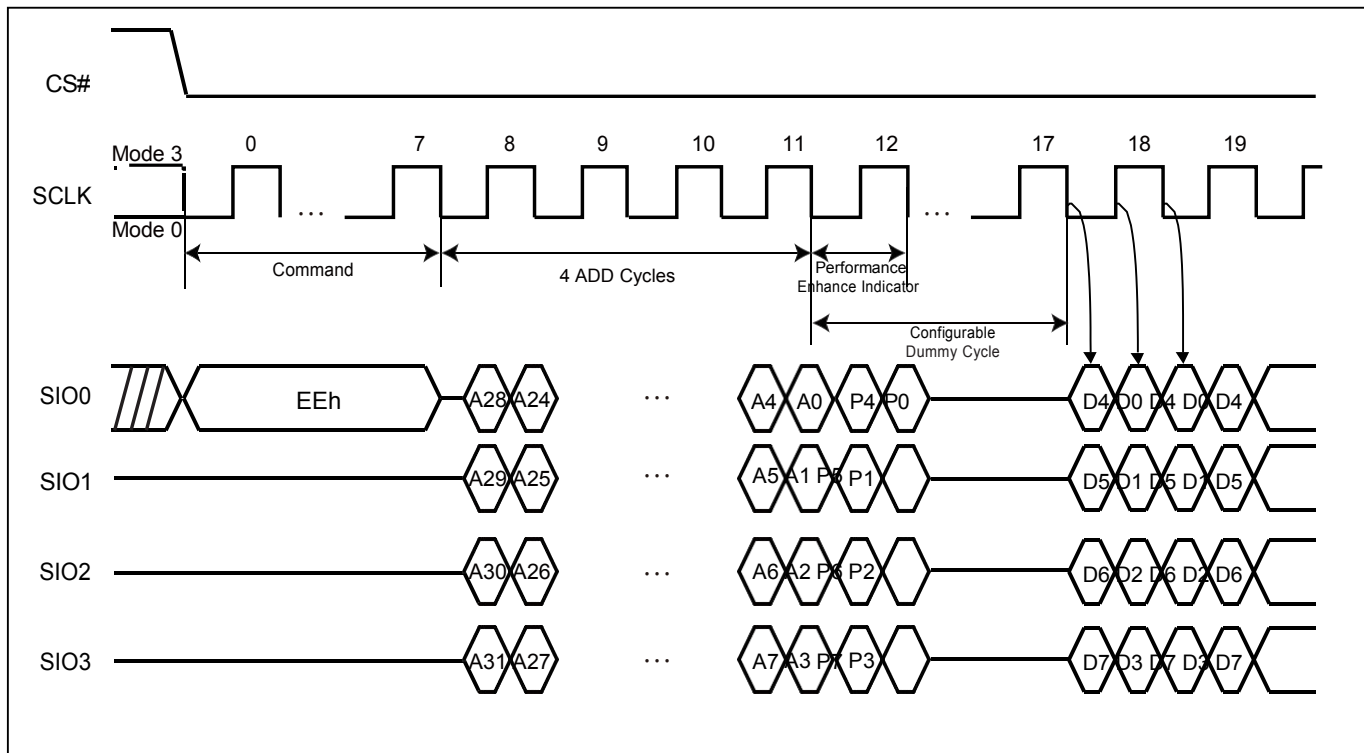

Figure 50. Fast Quad I/O DT Read (4DTRD4B) Sequence (SPI Mode)



Note:

1. Configuration Dummy cycle numbers will be different depending on the bit6 & bit7 (DC0 & DC1) setting in configuration register.

Figure 51. Fast Quad I/O DT Read (4DTRD4B) Sequence (QPI Mode)

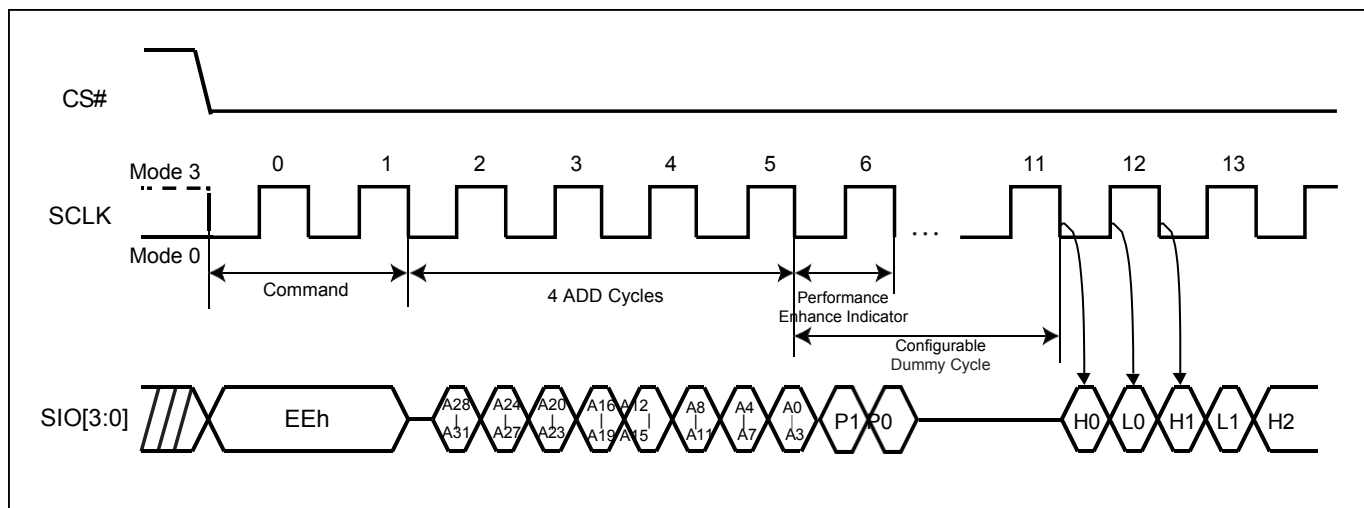

Note:

1. Configuration Dummy cycle numbers will be different depending on the bit6 & bit7 (DC0 & DC1) setting in configuration register.

9-22. Burst Read

The Burst Read feature allows applications to fill a cache line with a fixed length of data without using multiple read commands. Burst Read is disabled by default at power-up or reset. Burst Read is enabled by setting the Burst Length. When the Burst Length is set, reads will wrap on the selected boundary (8/16/32/64-bytes) containing the initial target address. For example if an 8-byte Wrap Depth is selected, reads will wrap on the 8-byte-page-aligned boundary containing the initial read address.

To set the Burst Length, drive CS# low → send SET BURST LENGTH instruction code (C0h) → send WRAP CODE →drive CS# high. Refer to the table below for valid 8-bit Wrap Codes and their corresponding Wrap Depth.

Data	Wrap Around	Wrap Depth
00h	Yes	8-byte
01h	Yes	16-byte
02h	Yes	32-byte
03h	Yes	64-byte
1xh	No	X

Once Burst Read is enabled, it will remain enabled until the device is power-cycled or reset. The SPI and QPI mode 4READ and 4READ4B read commands support the wrap around feature after Burst Read is enabled. To change the wrap depth, resend the Burst Read instruction with the appropriate Wrap Code. To disable Burst Read, send the Burst Read instruction with Wrap Code 1xh. QPI "EBh" "ECh" and SPI "EBh" "ECh" support wrap around feature after wrap around is enabled. Both SPI (8 clocks) and QPI (2 clocks) command cycle can be accepted by this instruction. The SIO[3:1] are don't care during SPI mode.

Figure 52. Burst Read (SPI Mode)

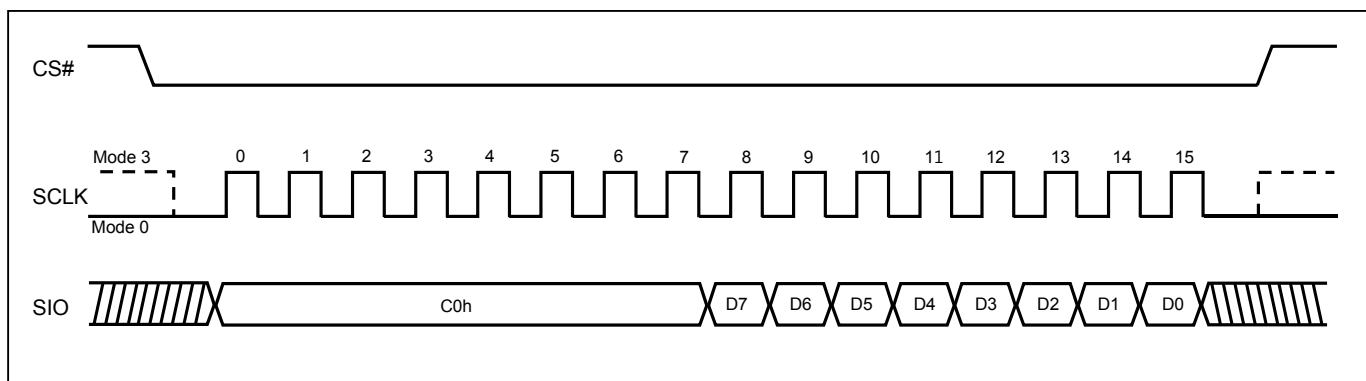
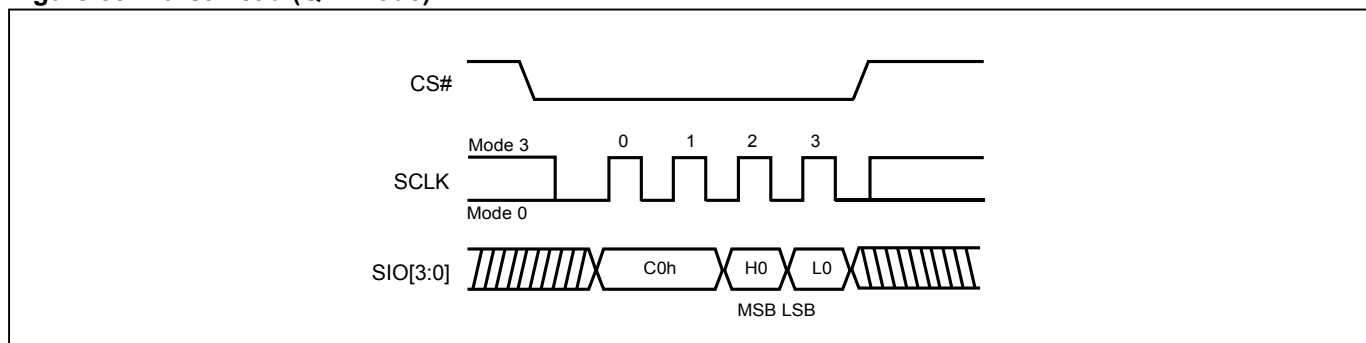

Figure 53. Burst Read (QPI Mode)



Note: MSB=Most Significant Bit
LSB=Least Significant Bit



9-23. Performance Enhance Mode

The device could waive the command cycle bits if the two cycle bits after address cycle toggles.

Performance enhance mode is supported in both SPI and QPI mode.

In QPI mode, "EBh" "ECh" "EDh" "EEh" and SPI "EBh" "ECh" "EDh" "EEh" commands support enhance mode. The performance enhance mode is not supported in dual I/O mode.

To enter performance-enhancing mode, P[7:4] must be toggling with P[3:0]; likewise P[7:0]=A5h, 5Ah, F0h or 0Fh can make this mode continue and skip the next 4READ instruction. To leave enhance mode, P[7:4] is no longer toggling with P[3:0]; likewise P[7:0]=FFh, 00h, AAh or 55h along with CS# is afterwards raised and then lowered. Issuing "FFh" data cycle can also exit enhance mode. The system then will leave performance enhance mode and return to normal operation.

To conduct the Performance Enhance Mode Reset operation in SPI mode, FFh data cycle(8 clocks in 3-byte address mode)/3FFh data cycle(10 clocks in 4-byte address mode), should be issued in I/O sequence. In QPI Mode, FFFFFFFFh data cycle(8 clocks in 3-byte address mode)/FFFFFFFFh data cycle (10 clocks in 4-byte address mode), in I/O should be issued. If the system controller is being Reset during operation, the flash device will return to the standard SPI operation.

After entering enhance mode, following CS# go high, the device will stay in the read mode and treat CS# go low of the first clock as address instead of command cycle.

Another sequence of issuing 4READ instruction especially useful in random access is: CS# goes low→send 4READ instruction→3-bytes or 4-bytes address interleave on SIO3, SIO2, SIO1 & SIO0 →performance enhance toggling bit P[7:0]→ 4 dummy cycles (Default) →data out until CS# goes high → CS# goes low (The following 4READ instruction is not allowed, hence 8 cycles of 4READ can be saved comparing to normal 4READ mode) → 3-bytes or 4-bytes random access address.

Figure 54. 4 x I/O Read enhance performance Mode Sequence (SPI Mode)

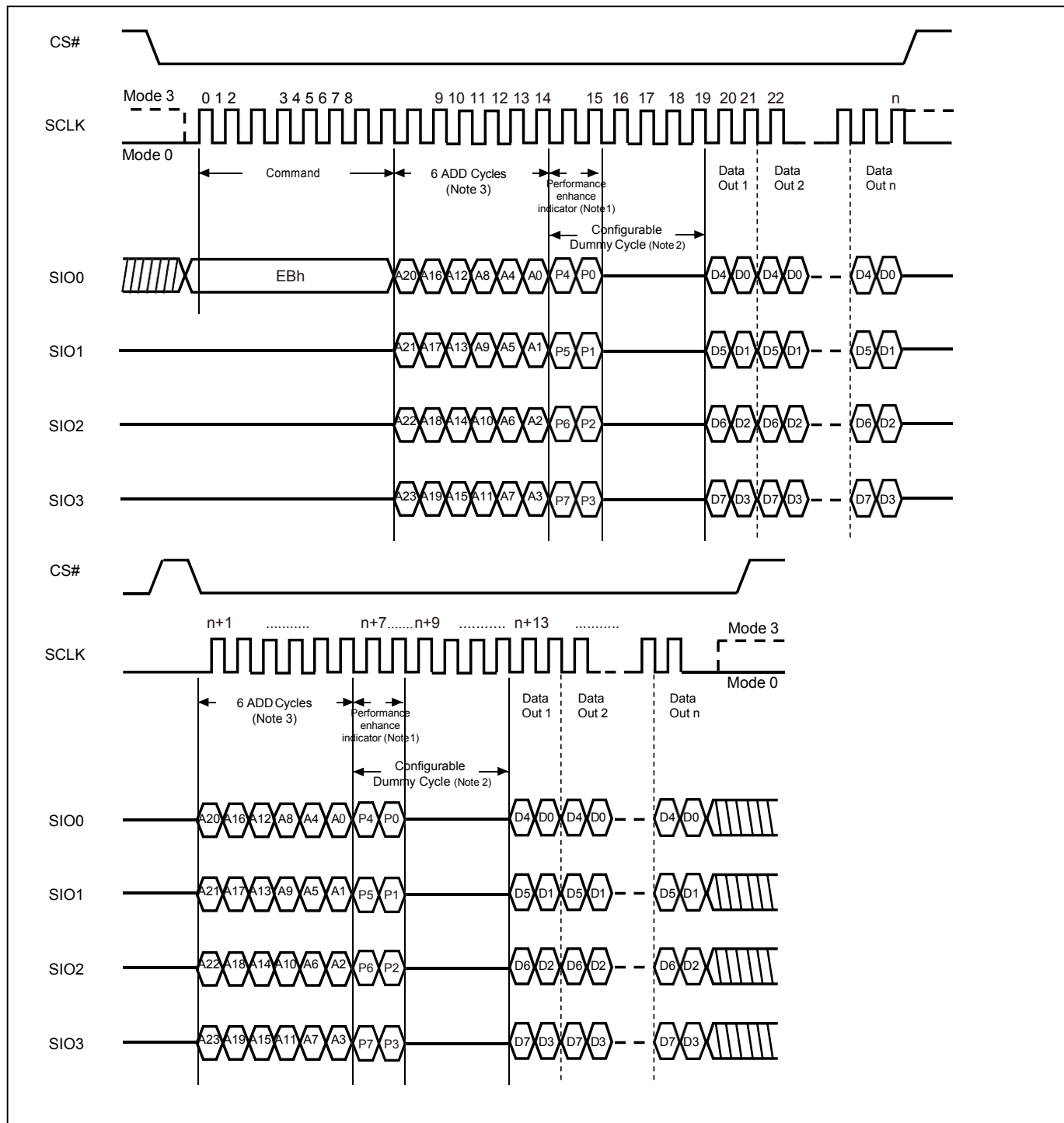

Notes:

1. If not using performance enhance recommend to keep 1 or 0 in performance enhance indicator.
2. Configuration Dummy cycle numbers will be different depending on the bit6 & bit 7 (DC0 & DC1) setting in configuration register.
3. Please note the address cycles above are based on 3-byte address mode. For 4-byte address mode, the address cycles will be increased.
4. Reset the performance enhance mode, if P7=P3 or P6=P2 or P5=P1 or P4=P0, ex: AA, 00, FF

Figure 55. 4 x I/O Read enhance performance Mode Sequence (QPI Mode)

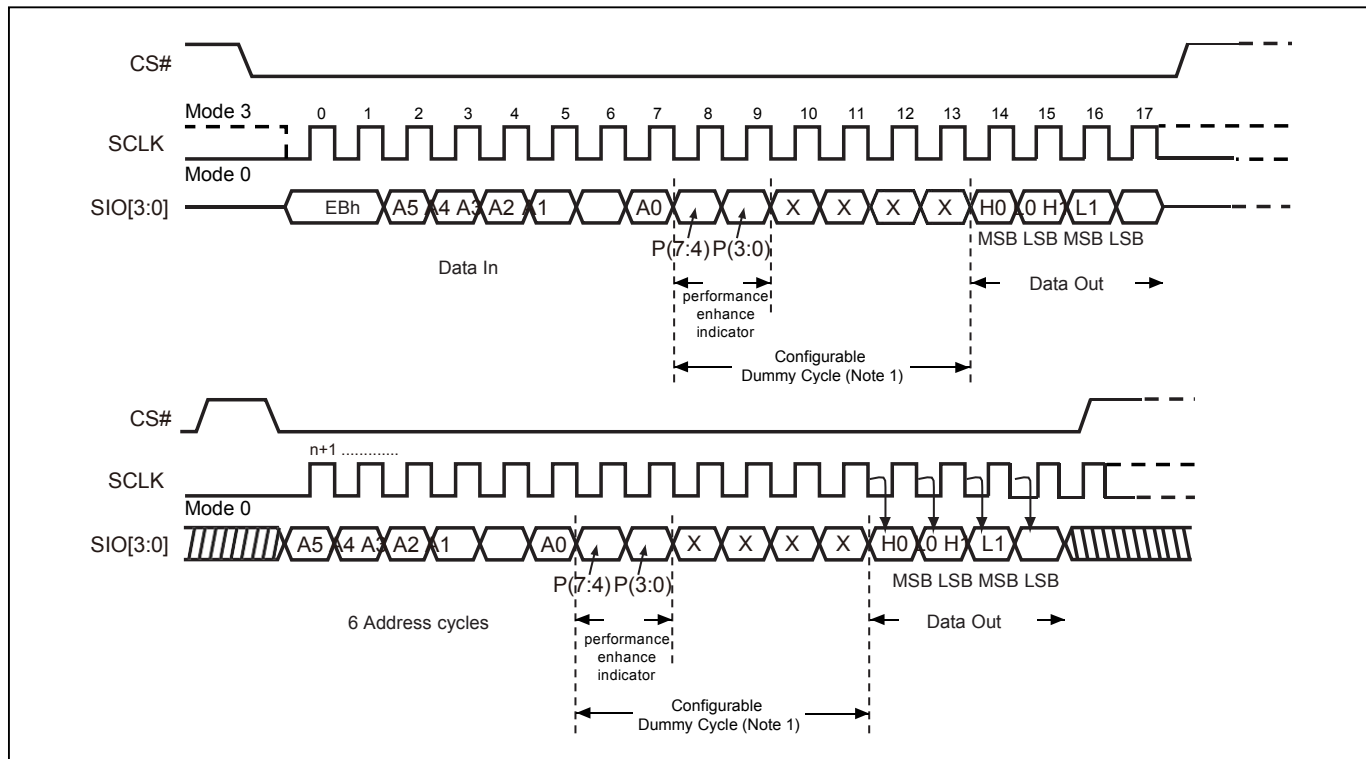

Notes:

1. Configuration Dummy cycle numbers will be different depending on the bit6 & bit 7 (DC0 & DC1) setting in configuration register.
2. Please note the address cycles above are based on 3-byte address mode. For 4-byte address mode, the address cycles will be increased.
3. Reset the performance enhance mode, if P7=P3 or P6=P2 or P5=P1 or P4=P0, ex: AA, 00, FF

9-24. Sector Erase (SE)

The Sector Erase (SE) instruction is for erasing the data of the chosen sector to be "1". The instruction is used for any 4K-byte sector. A Write Enable (WREN) instruction must execute to set the Write Enable Latch (WEL) bit before sending the Sector Erase (SE). Any address of the sector (Please refer to "Table 4. Memory Organization") is a valid address for Sector Erase (SE) instruction. The CS# must go high exactly at the byte boundary (the least significant bit of the address byte been latched-in); otherwise, the instruction will be rejected and not executed.

The default read mode is 3-byte address, to access higher address (4-byte address) which requires to enter the 4-byte address read mode or to define EAR bit. Address bits [Am-A12] (Am is the most significant address) select the sector address.

To enter the 4-byte address mode, please refer to "9-11. Enter 4-byte mode (EN4B)" section.

The sequence of issuing SE instruction is: CS# goes low → sending SE instruction code → 3-byte or 4-byte address on SI → CS# goes high.

Both SPI (8 clocks) and QPI (2 clocks) command cycle can accept by this instruction. The SIO[3:1] are don't care when during SPI mode.

The self-timed Sector Erase Cycle time (tSE) is initiated as soon as Chip Select (CS#) goes high. The Write in Progress (WIP) bit still can be checked while the Sector Erase cycle is in progress. The WIP sets 1 during the tSE timing, and clears when Sector Erase Cycle is completed, and the Write Enable Latch (WEL) bit is cleared. If the Block is protected by BP bits (WPSEL=0; Block Protect Mode) or SPB (WPSEL=1; Individual Sector Protect Mode), the Sector Erase (SE) instruction will not be executed on the block.

Figure 56. Sector Erase (SE) Sequence (SPI Mode)

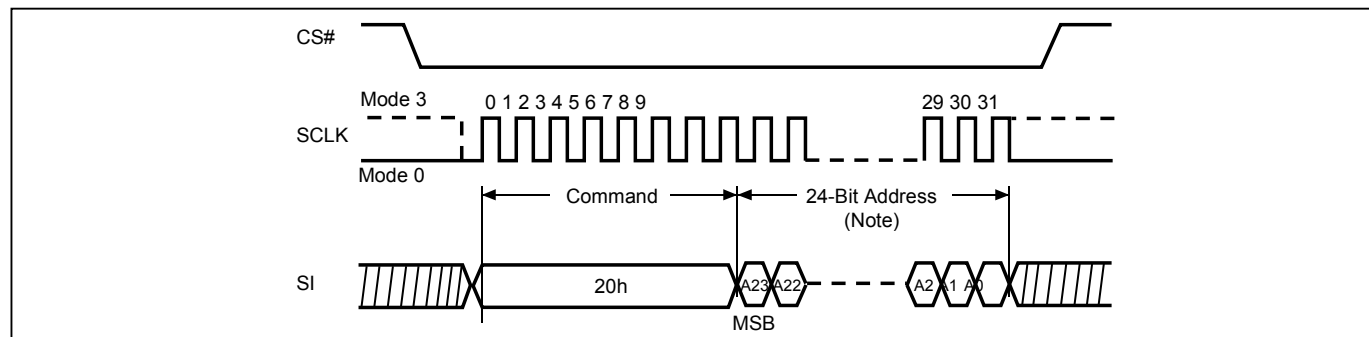

Note: Please note the address cycles above are based on 3-byte address mode. For 4-byte address mode, the address cycles will be increased.

Figure 57. Sector Erase (SE) Sequence (QPI Mode)

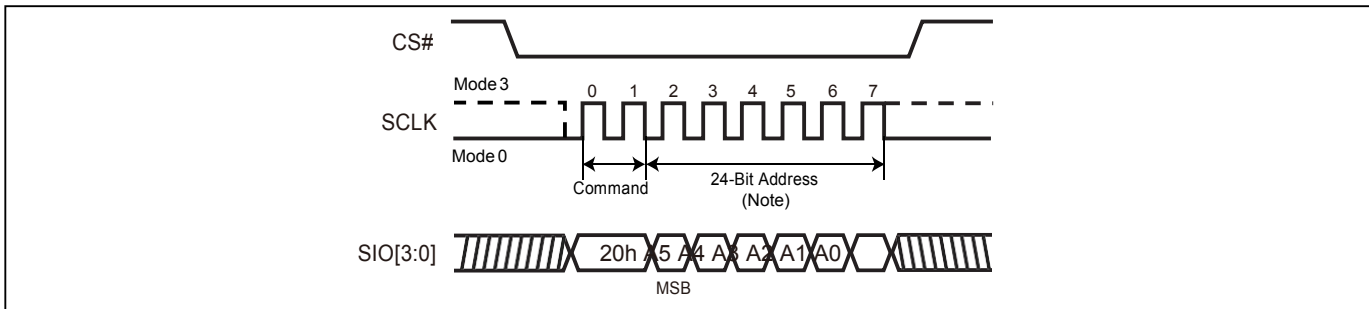

Note: Please note the address cycles above are based on 3-byte address mode. For 4-byte address mode, the address cycles will be increased.

9-25. Block Erase (BE32K)

The Block Erase (BE32K) instruction is for erasing the data of the chosen block to be "1". The instruction is used for 32K-byte block erase operation. A Write Enable (WREN) instruction be executed to set the Write Enable Latch (WEL) bit before sending the Block Erase (BE32K). Any address of the block (see "Table 4. Memory Organization") is a valid address for Block Erase (BE32K) instruction. The CS# must go high exactly at the byte boundary (the least significant bit of address byte been latched-in); otherwise, the instruction will be rejected and not executed.

Address bits [Am-A15] (Am is the most significant address) select the 32KB block address. The default read mode is 3-byte address, to access higher address (4-byte address) which requires to enter the 4-byte address read mode or to define EAR bit. To enter the 4-byte address mode, please refer to the enter 4-byte mode (EN4B) Mode section.

The sequence of issuing BE32K instruction is: CS# goes low→ sending BE32K instruction code→ 3-byte or 4-byte address on SI→CS# goes high.

Both SPI (8 clocks) and QPI (2 clocks) command cycle can accept by this instruction. The SIO[3:1] are don't care when during SPI mode.

The self-timed Block Erase Cycle time (tBE32K) is initiated as soon as Chip Select (CS#) goes high. The Write in Progress (WIP) bit still can be checked while during the Block Erase cycle is in progress. The WIP sets during the tBE32K timing, and clears when Block Erase Cycle is completed, and the Write Enable Latch (WEL) bit is cleared. If the Block is protected by BP bits (WPSEL=0; Block Protect Mode) or SPB (WPSEL=1; Individual Sector Protect Mode), the Block Erase (BE32K) instruction will not be executed on the block.

Figure 58. Block Erase 32KB (BE32K) Sequence (SPI Mode)

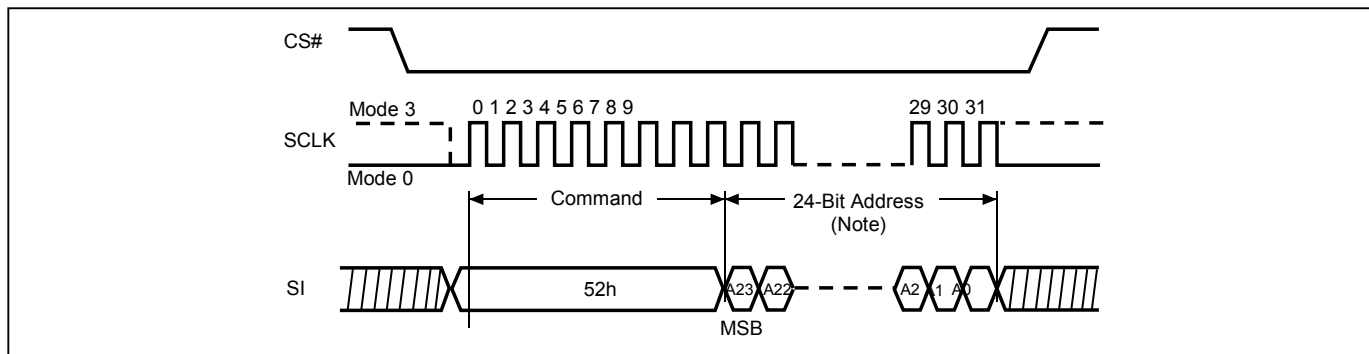

Note: Please note the address cycles above are based on 3-byte address mode. For 4-byte address mode, the address cycles will be increased.

Figure 59. Block Erase 32KB (BE32K) Sequence (QPI Mode)

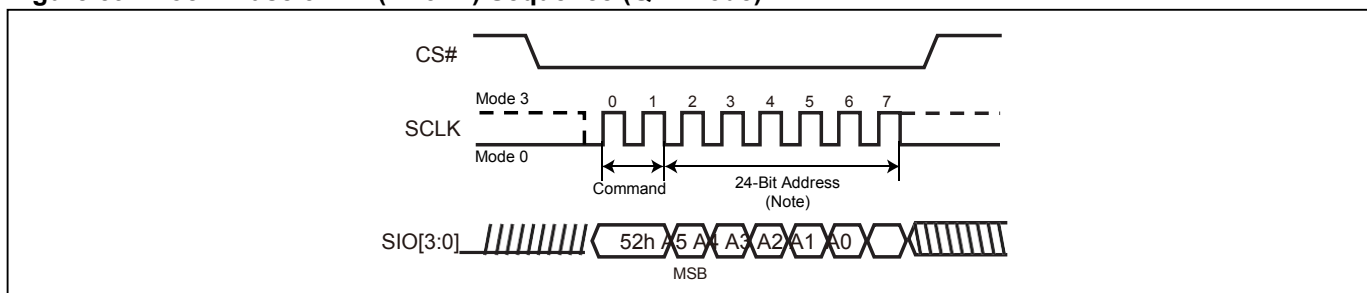

Note: Please note the address cycles above are based on 3-byte address mode. For 4-byte address mode, the address cycles will be increased.

9-26. Block Erase (BE)

The Block Erase (BE) instruction is for erasing the data of the chosen block to be "1". The instruction is used for 64K-byte block erase operation. A Write Enable (WREN) instruction must be executed to set the Write Enable Latch (WEL) bit before sending the Block Erase (BE). Any address of the block (Please refer to "Table 4. Memory Organization") is a valid address for Block Erase (BE) instruction. The CS# must go high exactly at the byte boundary (the least significant bit of address byte been latched-in); otherwise, the instruction will be rejected and not executed.

The default read mode is 3-byte address, to access higher address (4-byte address) which requires to enter the 4-byte address read mode or to define EAR bit. To enter the 4-byte address mode, please refer to the "9-11. Enter 4-byte mode (EN4B)" Mode section.

The sequence of issuing BE instruction is: CS# goes low → sending BE instruction code → 3-byte or 4-byte address on SI → CS# goes high.

Both SPI (8 clocks) and QPI (2 clocks) command cycle can accept by this instruction. The SIO[3:1] are don't care when during SPI mode.

The self-timed Block Erase Cycle time (tBE) is initiated as soon as Chip Select (CS#) goes high. The Write in Progress (WIP) bit still can be checked while the Block Erase cycle is in progress. The WIP sets during the tBE timing, and clears when Block Erase Cycle is completed, and the Write Enable Latch (WEL) bit is reset. If the Block is protected by BP bits (WPSEL=0; Block Protect Mode) or SPB (WPSEL=1; Individual Sector Protect Mode), the Block Erase (BE) instruction will not be executed on the block.

Figure 60. Block Erase (BE) Sequence (SPI Mode)

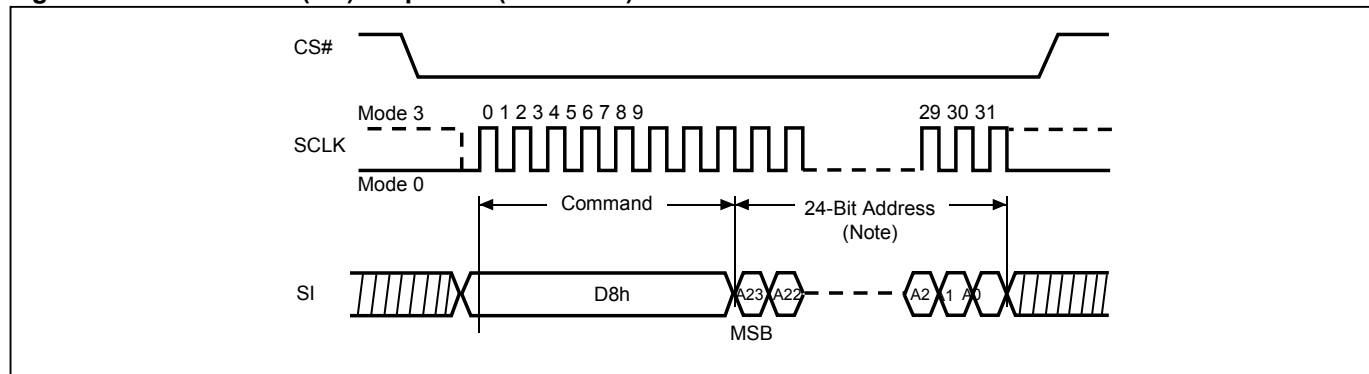

Note: Please note the address cycles above are based on 3-byte address mode. For 4-byte address mode, the address cycles will be increased.

Figure 61. Block Erase (BE) Sequence (QPI Mode)

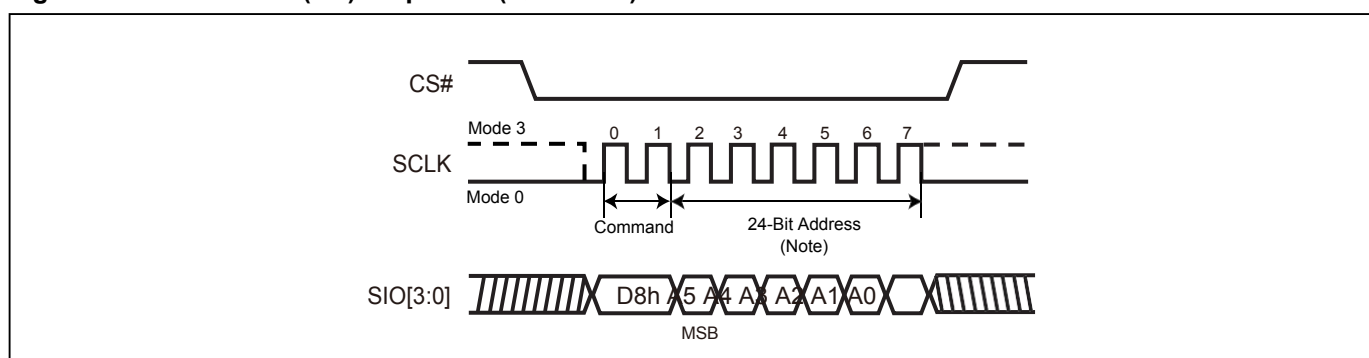

Note: Please note the address cycles above are based on 3-byte address mode. For 4-byte address mode, the address cycles will be increased.

9-27. Chip Erase (CE)

The Chip Erase (CE) instruction is for erasing the data of the whole chip to be "1". A Write Enable (WREN) instruction must be executed to set the Write Enable Latch (WEL) bit before sending the Chip Erase (CE). The CS# must go high exactly at the byte boundary, otherwise the instruction will be rejected and not executed.

The sequence of issuing CE instruction is: CS# goes low→sending CE instruction code→CS# goes high.

Both SPI (8 clocks) and QPI (2 clocks) command cycle can accept by this instruction. The SIO[3:1] are don't care when during SPI mode.

The self-timed Chip Erase Cycle time (tCE) is initiated as soon as Chip Select (CS#) goes high. The Write in Progress (WIP) bit still can be checked while the Chip Erase cycle is in progress. The WIP sets during the tCE timing, and clears when Chip Erase Cycle is completed, and the Write Enable Latch (WEL) bit is cleared.

When the chip is under "Block protect (BP) Mode" (WPSEL=0). The Chip Erase (CE) instruction will not be executed, if one (or more) sector is protected by BP3-BP0 bits. It will be only executed when BP3-BP0 all set to "0".

When the chip is under "Advances Sector Protect Mode" (WPSEL=1). The Chip Erase (CE) instruction will be executed on unprotected block. The protected Block will be skipped. If one (or more) 4K byte sector was protected in top or bottom 64K byte block, the protected block will also skip the chip erase command.

Figure 62. Chip Erase (CE) Sequence (SPI Mode)

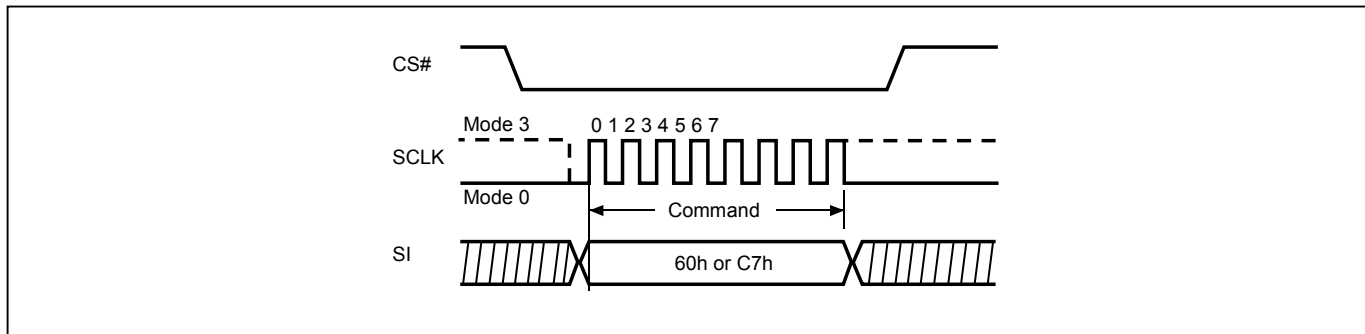
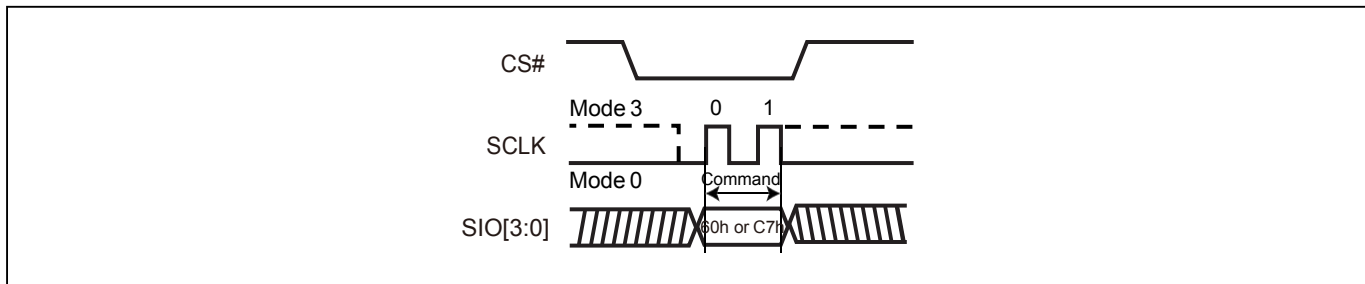

Figure 63. Chip Erase (CE) Sequence (QPI Mode)





9-28. Page Program (PP)

The Page Program (PP) instruction is for programming memory bits to "0". One to 256 bytes can be sent to the device to be programmed. A Write Enable (WREN) instruction must be executed to set the Write Enable Latch (WEL) bit before sending the Page Program (PP). If more than 256 data bytes are sent to the device, only the last 256 data bytes will be accepted and the previous data bytes will be disregarded. The Page Program instruction requires that all the data bytes fall within the same 256-byte page. The low order address byte A[7:0] specifies the starting address within the selected page. Bytes that will cross a page boundary will wrap to the beginning of the selected page. The device can accept (256 minus A[7:0]) data bytes without wrapping. If 256 data bytes are going to be programmed, A[7:0] should be set to 0.

The default read mode is 3-byte address, to access higher address (4-byte address) which requires to enter the 4-byte address read mode or to define EAR bit. To enter the 4-byte address mode, please refer to the ["9-11. Enter 4-byte mode \(EN4B\)"](#) section.

The sequence of issuing PP instruction is: CS# goes low → sending PP instruction code → 3-byte or 4-byte address on SI → at least 1-byte on data on SI → CS# goes high.

The CS# must be kept to low during the whole Page Program cycle; The CS# must go high exactly at the byte boundary (the latest eighth bit of data being latched in), otherwise the instruction will be rejected and will not be executed.

The self-timed Page Program Cycle time (tPP) is initiated as soon as Chip Select (CS#) goes high. The Write in Progress (WIP) bit still can be checked while the Page Program cycle is in progress. The WIP sets during the tPP timing, and clears when Page Program Cycle is completed, and the Write Enable Latch (WEL) bit is cleared. If the page is protected by BP bits (WPSEL=0; Block Protect Mode) or SPB (WPSEL=1; Individual Sector Protect Mode), the Page Program (PP) instruction will not be executed.

Both SPI (8 clocks) and QPI (2 clocks) command cycle can accept by this instruction. The SIO[3:1] are don't care when during SPI mode.

Figure 64. Page Program (PP) Sequence (SPI Mode)

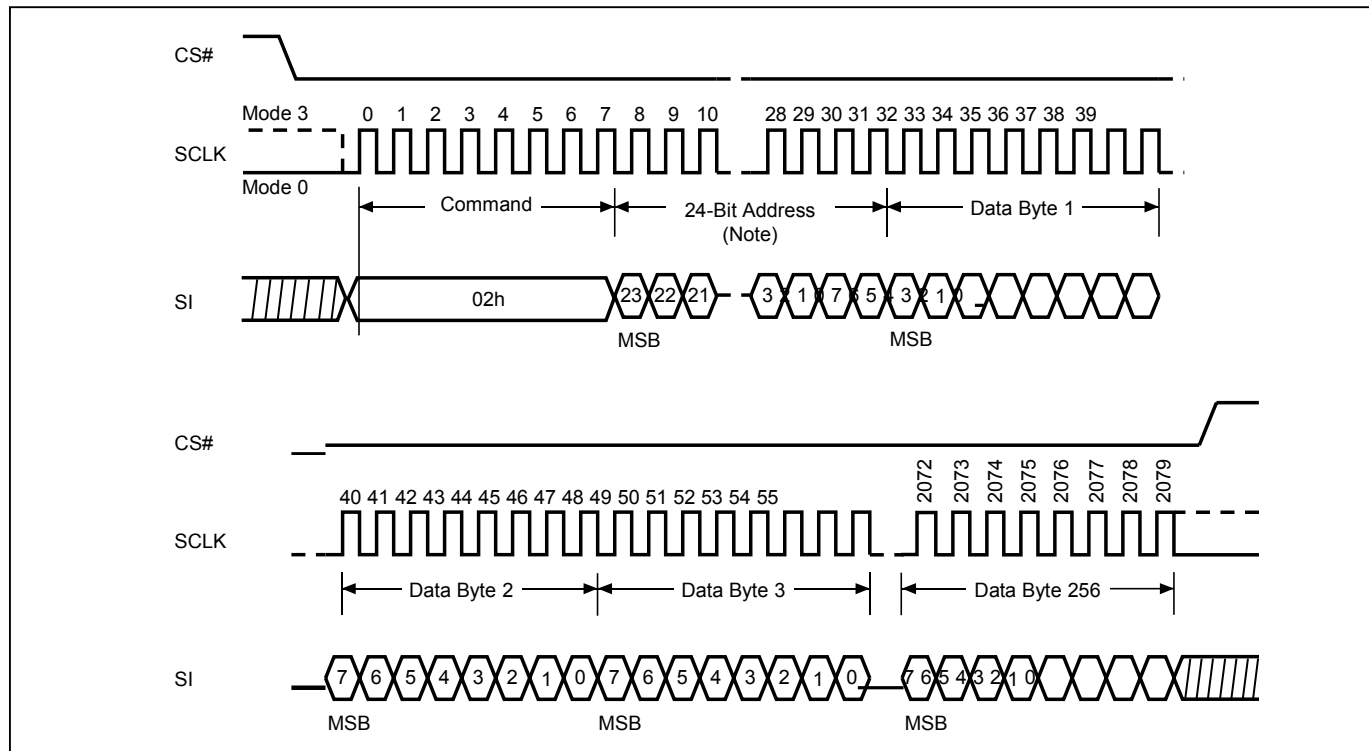

Note: Please note the address cycles above are based on 3-byte address mode. For 4-byte address mode, the address cycles will be increased.

Figure 65. Page Program (PP) Sequence (QPI Mode)

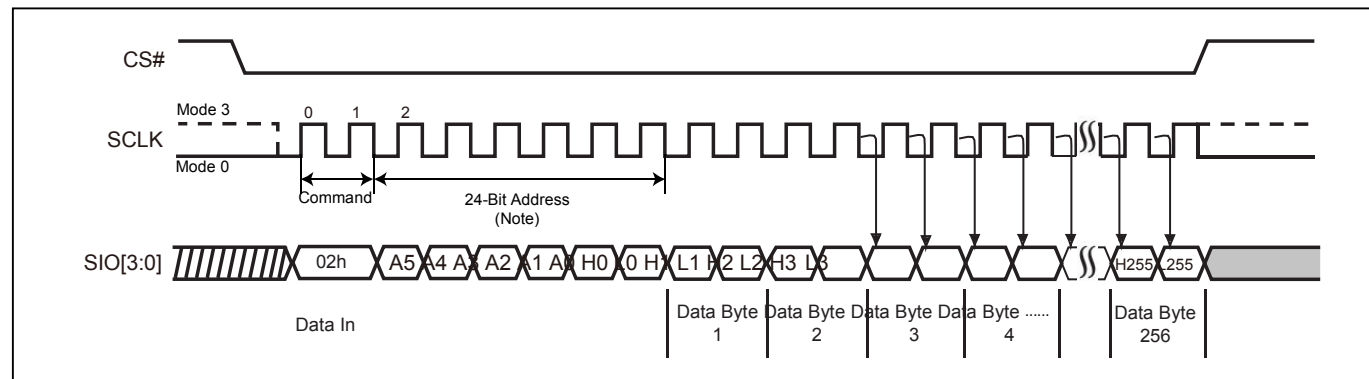

Note: Please note the address cycles above are based on 3-byte address mode. For 4-byte address mode, the address cycles will be increased.

9-29. 4 x I/O Page Program (4PP)

The Quad Page Program (4PP) instruction is for programming the memory to be "0". A Write Enable (WREN) instruction must be executed to set the Write Enable Latch (WEL) bit and Quad Enable (QE) bit must be set to "1" before sending the Quad Page Program (4PP). The Quad Page Programming takes four pins: SIO0, SIO1, SIO2, and SIO3 as address and data input, which can improve programmer performance and the effectiveness of application. The other function descriptions are as same as standard page program.

The default read mode is 3-byte address, to access higher address (4-byte address) which requires to enter the 4-byte address read mode or to define EAR bit. To enter the 4-byte address mode, please refer to the "9-11. Enter 4-byte mode (EN4B)" section.

The sequence of issuing 4PP instruction is: CS# goes low → sending 4PP instruction code → 3-byte or 4-byte address on SIO[3:0] → at least 1-byte on data on SIO[3:0] → CS# goes high.

If the page is protected by BP bits (WPSEL=0; Block Protect Mode) or SPB (WPSEL=1; Individual Sector Protect Mode), the Quad Page Program (4PP) instruction will not be executed.

Figure 66. 4 x I/O Page Program (4PP) Sequence (SPI Mode only)

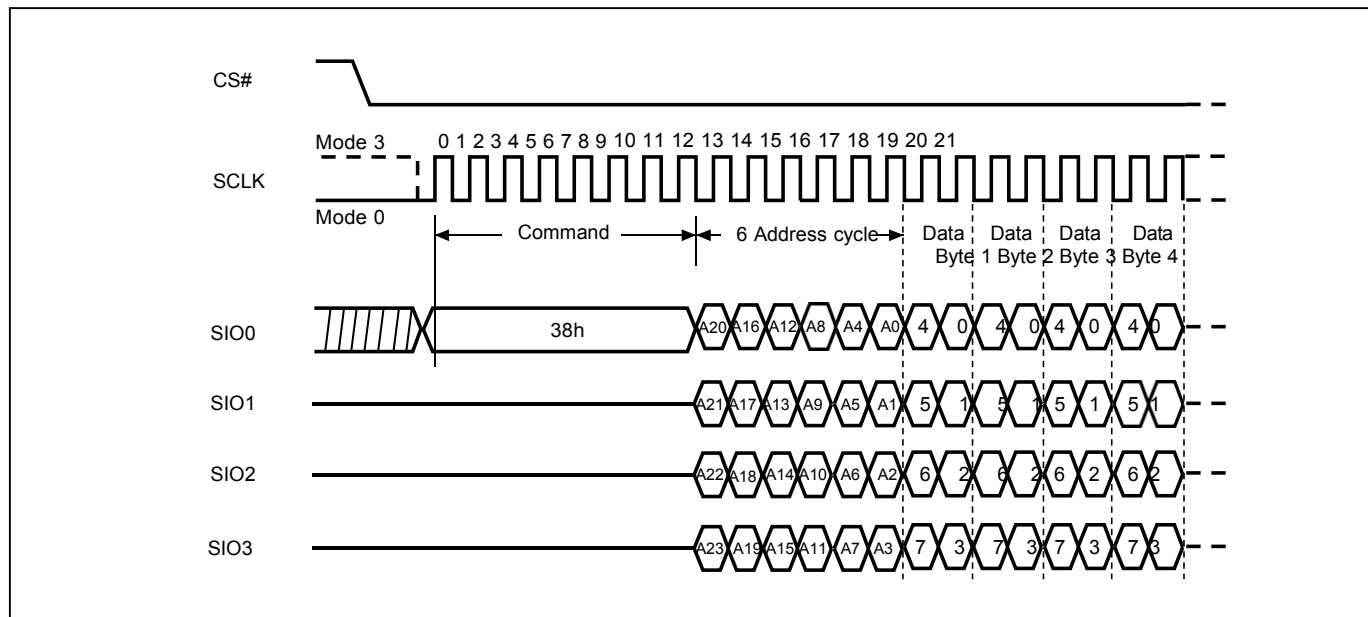

Note: Please note the address cycles above are based on 3-byte address mode. For 4-byte address mode, the address cycles will be increased.

9-30. Deep Power-down (DP)

The Deep Power-down (DP) instruction places the device into a minimum power consumption state, Deep Power-down mode, in which the quiescent current is reduced from ISB1 to ISB2.

The sequence of issuing DP instruction: CS# goes low → send DP instruction code → CS# goes high. The CS# must go high at the byte boundary (after exactly eighth bits of the instruction code have been latched-in); otherwise the instruction will not be executed. Both SPI (8 clocks) and QPI (2 clocks) command cycle can be accepted by this instruction. SIO[3:1] are "don't care".

After CS# goes high there is a delay of t_{DP} before the device transitions from Stand-by mode to Deep Power-down mode and before the current reduces from ISB1 to ISB2. Once in Deep Power-down mode, all instructions will be ignored except Release from Deep Power-down (RDP).

The device exits Deep Power-down mode and returns to Stand-by mode if it receives a Release from Deep Power-down (RDP) instruction, power-cycle, or reset. Please refer to "[Figure 18. Release from Deep Power-down \(RDP\) Sequence \(SPI Mode\)](#)" and "[Figure 19. Release from Deep Power-down \(RDP\) Sequence \(QPI Mode\)](#)".

Figure 67. Deep Power-down (DP) Sequence (SPI Mode)

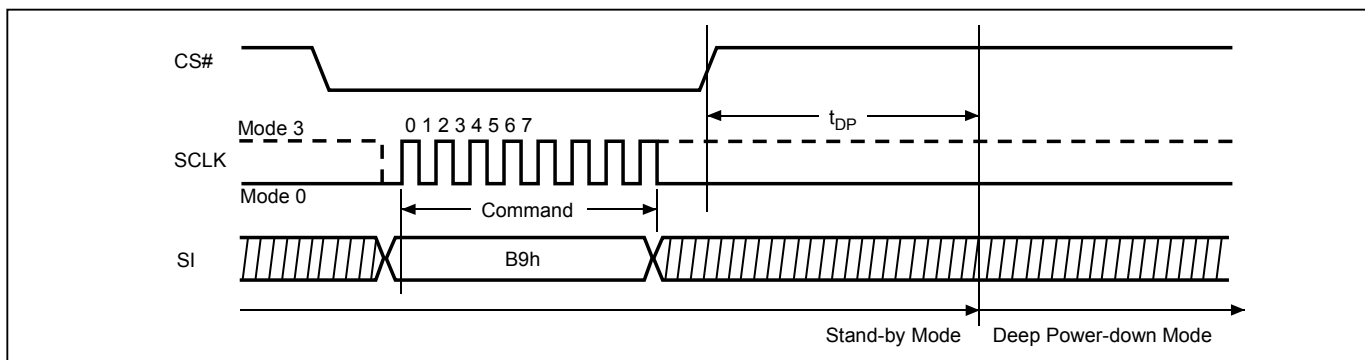
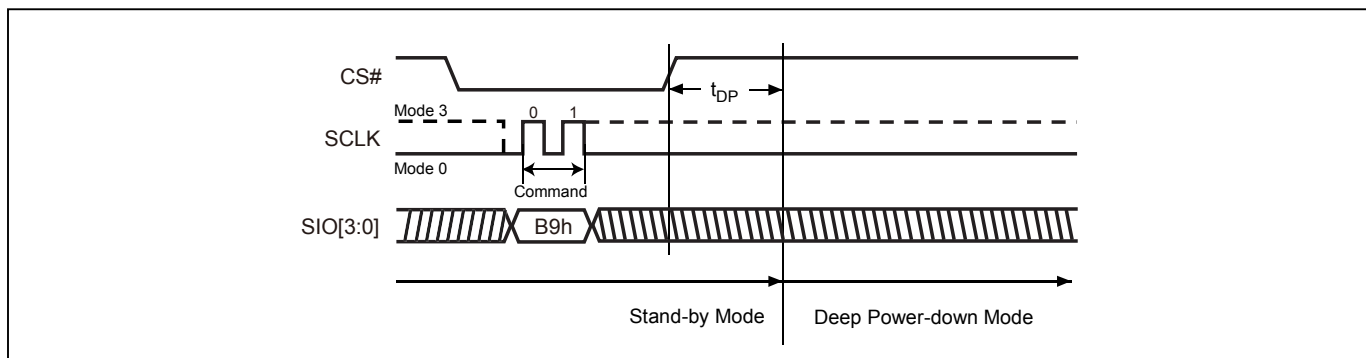

Figure 68. Deep Power-down (DP) Sequence (QPI Mode)



9-31. Write Security Register (WRSCUR)

The WRSCUR instruction is for changing the values of Security Register Bits. The WREN (Write Enable) instruction is required before issuing WRSCUR instruction. The WRSCUR instruction may change the values of bit1 (LDSO bit) for customer to lock-down the 4K-bit Secured OTP area. Once the LDSO bit is set to "1", the Secured OTP area cannot be updated any more.

The sequence of issuing WRSCUR instruction is :CS# goes low→ send WRSCUR instruction → CS# goes high.

Both SPI (8 clocks) and QPI (2 clocks) command cycle can accept by this instruction. The SIO[3:1] are don't care when during SPI mode.

The CS# must go high exactly at the boundary; otherwise, the instruction will be rejected and not executed.

Figure 69. Write Security Register (WRSCUR) Sequence (SPI Mode)

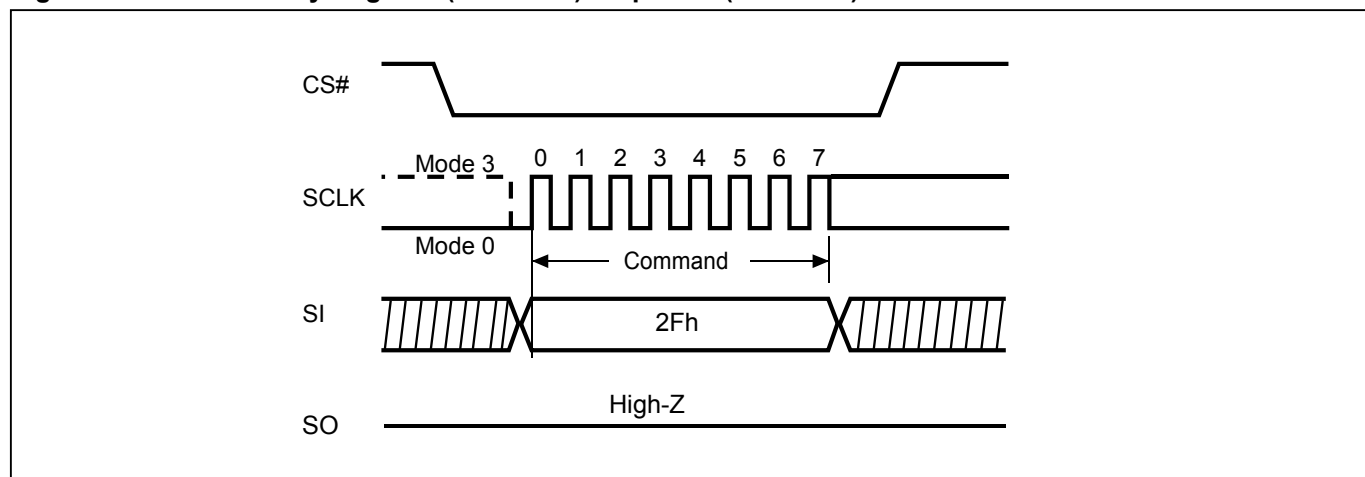
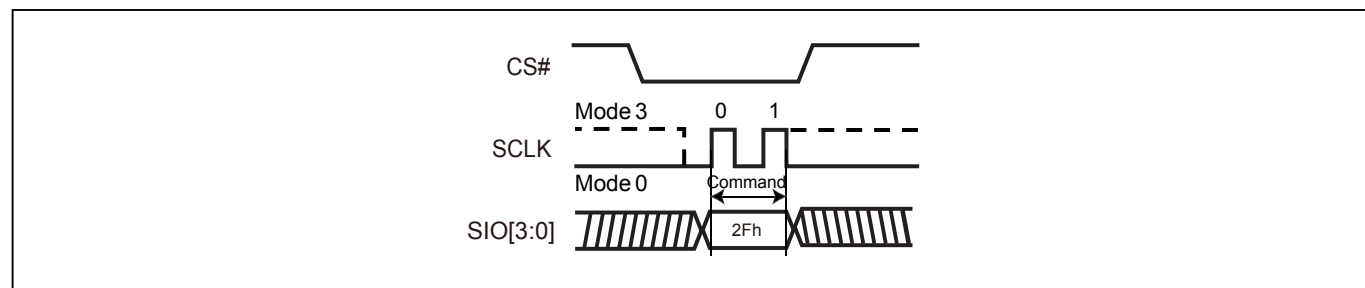

Figure 70. Write Security Register (WRSCUR) Sequence (QPI Mode)



9-32. Read Security Register (RDSCUR)

The RDSCUR instruction is for reading the value of Security Register bits. The Read Security Register can be read at any time (even in program/erase/write status register/write security register condition) and continuously.

The sequence of issuing RDSCUR instruction is : CS# goes low→sending RDSCUR instruction→Security Register data out on SO→ CS# goes high.

Both SPI (8 clocks) and QPI (2 clocks) command cycle can accept by this instruction. The SIO[3:1] are don't care when during SPI mode.

Figure 71. Read Security Register (RDSCUR) Sequence (SPI Mode)

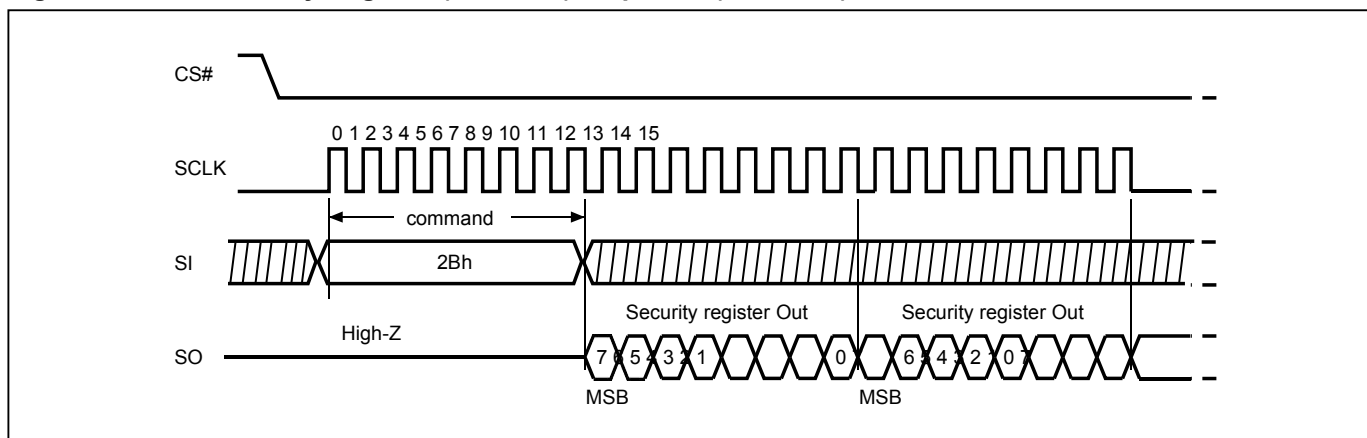
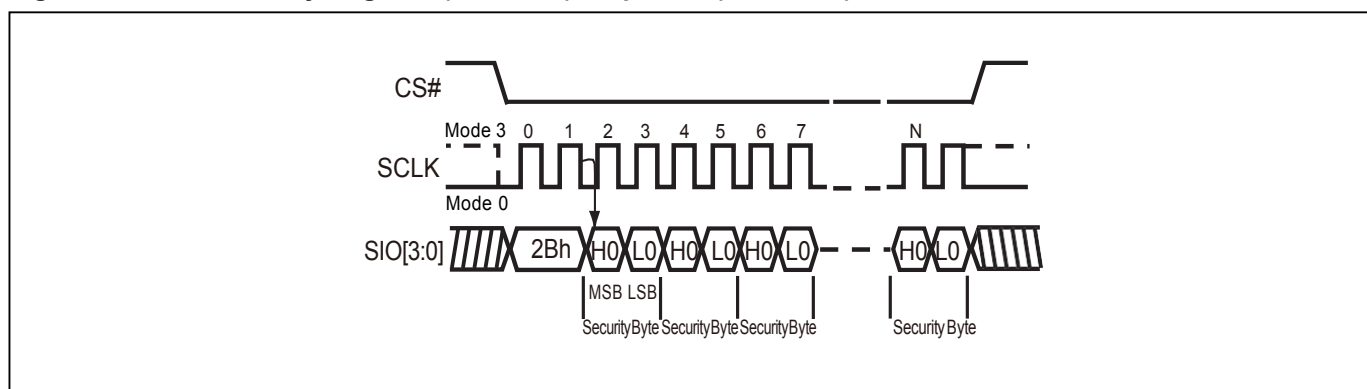

Figure 72. Read Security Register (RDSCUR) Sequence (QPI Mode)





9-33. Enter Secured OTP (ENSO)

The ENSO instruction is for entering the additional 4K-bit secured OTP mode. While device is in 4K-bit secured OTP mode, main array access is not available. The additional 4K-bit secured OTP is independent from main array and may be used to store unique serial number for system identifier. After entering the Secured OTP mode, follow standard read or program procedure to read out the data or update data. The Secured OTP data cannot be updated again once it is lock-down.

The sequence of issuing ENSO instruction is: CS# goes low→ sending ENSO instruction to enter Secured OTP mode→ CS# goes high.

Both SPI (8 clocks) and QPI (2 clocks) command cycle can accept by this instruction. The SIO[3:1] are don't care when during SPI mode.

Please note that after issuing ENSO command user can only access secure OTP region with standard read or program procedure. Furthermore, once security OTP is lock down, only read related commands are valid.

9-34. Exit Secured OTP (EXSO)

The EXSO instruction is for exiting the additional 4K-bit secured OTP mode.

The sequence of issuing EXSO instruction is: CS# goes low→ sending EXSO instruction to exit Secured OTP mode→ CS# goes high.

Both SPI (8 clocks) and QPI (2 clocks) command cycle can accept by this instruction. The SIO[3:1] are don't care when during SPI mode.



Security Register

The definition of the Security Register bits is as below:

Write Protection Selection bit. Please refer to "9-35. Write Protection Selection (WPSEL)".

Erase Fail bit. The Erase Fail bit is a status flag, which shows the status of last Erase operation. It will be set to "1" if the erase operation fails. It will be cleared to "0" if the next erase operation succeeds. Please note that it will not interrupt or stop any operation in the flash memory.

Program Fail bit. The Program Fail bit is a status flag, which shows the status of the last Program operation. It will be set to "1" if the program operation fails or the program region was protected. It will be cleared to "0" if the next program operation succeeds. Please note that it will not interrupt or stop any operation in the flash memory.

Erase Suspend bit. Erase Suspend Bit (ESB) indicates the status of Erase Suspend operation. Users may use ESB to identify the state of flash memory. After the flash memory is suspended by Erase Suspend command, ESB is set to "1". ESB is cleared to "0" after erase operation resumes.

Program Suspend bit. Program Suspend Bit (PSB) indicates the status of Program Suspend operation. Users may use PSB to identify the state of flash memory. After the flash memory is suspended by Program Suspend command, PSB is set to "1". PSB is cleared to "0" after program operation resumes.

Secured OTP Indicator bit. The Secured OTP indicator bit shows the Secured OTP area is locked by factory or not. When it is "0", it indicates non-factory lock; "1" indicates factory-lock.

Lock-down Secured OTP (LDSO) bit. By writing WRSCUR instruction, the LDSO bit may be set to "1" for customer lock-down purpose. However, once the bit is set to "1" (lock-down), the LDSO bit and the 4K-bit Secured OTP area cannot be updated any more. While it is in 4K-bit secured OTP mode, main array access is not allowed.

Table 12. Security Register Definition

bit7	bit6	bit5	bit4	bit3	bit2	bit1	bit0
WPSEL	E_FAIL	P_FAIL	Reserved	ESB (Erase Suspend bit)	PSB (Program Suspend bit)	LDSO (indicate if lock-down)	Secured OTP indicator bit
0=Block Lock (BP) protection mode 1=Individual Sector protection mode (default=0)	0=normal Erase succeed 1=indicate Erase failed (default=0)	0=normal Program succeed 1=indicate Program failed (default=0)	-	0=Erase is not suspended 1= Erase suspended (default=0)	0=Program is not suspended 1= Program suspended (default=0)	0 = not lock-down 1 = lock-down (cannot program/erase OTP)	0 = non-factory lock 1 = factory lock
Non-volatile bit (OTP)	Volatile bit	Volatile bit	Volatile bit	Volatile bit	Volatile bit	Non-volatile bit (OTP)	Non-volatile bit (OTP)

9-35. Write Protection Selection (WPSEL)

There are two write protection methods provided on this device, (1) Block Protection (BP) mode or (2) Individual Sector Protection mode. The protection modes are mutually exclusive. The WPSEL bit selects which protection mode is enabled. If WPSEL=0 (factory default), BP mode is enabled and Individual Sector Protection mode is disabled. If WPSEL=1, Individual Sector Protection mode is enabled and BP mode is disabled. The WPSEL command is used to set WPSEL=1. A WREN command must be executed to set the WEL bit before sending the WPSEL command. Please note that the WPSEL bit is an OTP bit. Once WPSEL is set to “1”, it cannot be programmed back to “0”.

When WPSEL = 0: Block Lock (BP) protection mode,

The memory array is write protected by the BP3 to BP0 bits.

When WPSEL =1: Individual Sector protection mode,

Blocks are individually protected by their own SPB or DPB. On power-up, all blocks are write protected by the Dynamic Protection Bits (DPB) by default. The Individual Sector Protection instructions WRLR, RDLR, WRSPB, ESSPB, WRDPB, RDDPB, GBLK, and GBULK are activated. The BP3 to BP0 bits of the Status Register are disabled and have no effect.

The sequence of issuing WPSEL instruction is: CS# goes low → send WPSEL instruction to enable the Individual Sector Protect mode → CS# goes high.

Write Protection Selection

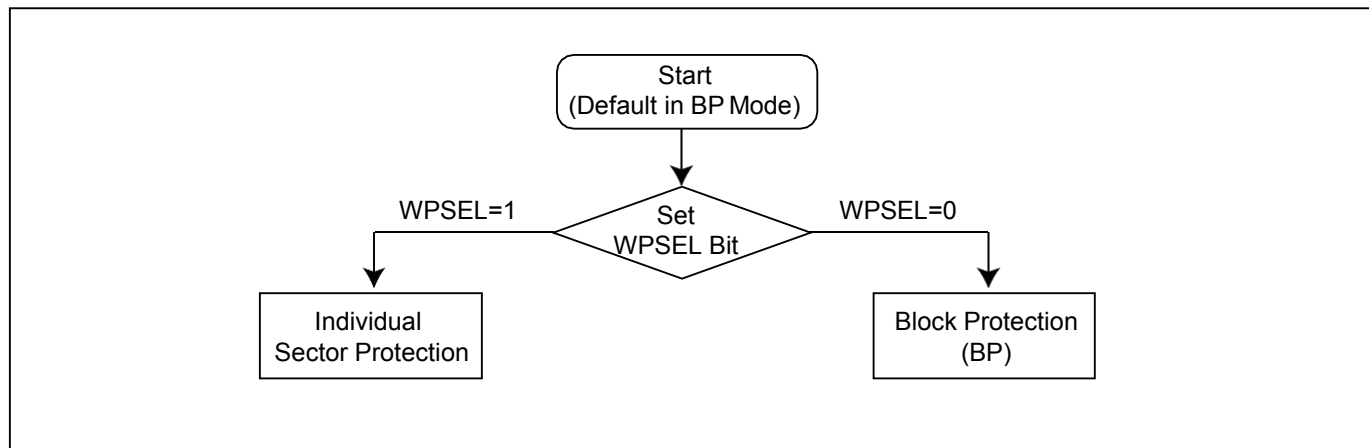
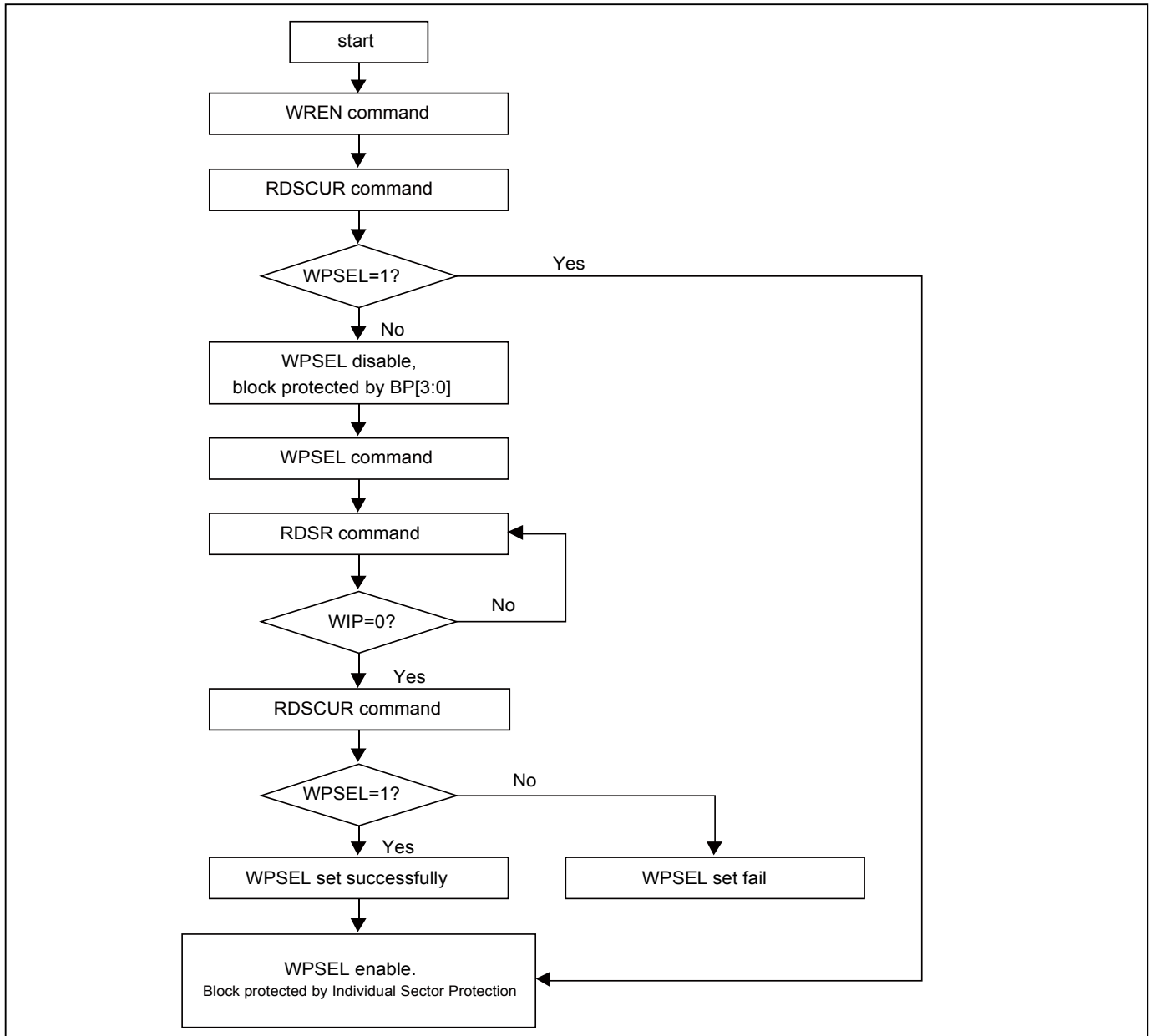

Figure 73. WPSEL Flow



9-36. Advanced Sector Protection

Advanced Sector Protection can protect individual 4KB sectors in the bottom and top 64KB of memory and protect individual 64KB blocks in the rest of memory.

There is one non-volatile Solid Protection Bit (SPB) and one volatile Dynamic Protection Bit (DPB) assigned to each 4KB sector at the bottom and top 64KB of memory and to each 64KB block in the rest of memory. A sector or block is write-protected from programming or erasing when its associated SPB or DPB is set to "1". The Unprotect Solid Protect Bit (USPB) can temporarily override and disable the write-protection provided by the SPB bits.

The figure below helps describing an overview of these methods. The device is default to the Solid mode when shipped from factory. The detail algorithm of advanced sector protection is shown as follows:

Solid Protection mode permits the SPB bits to be modified after power-on or a reset. The figure below is an overview of Advanced Sector Protection.

Figure 74. Advanced Sector Protection Overview

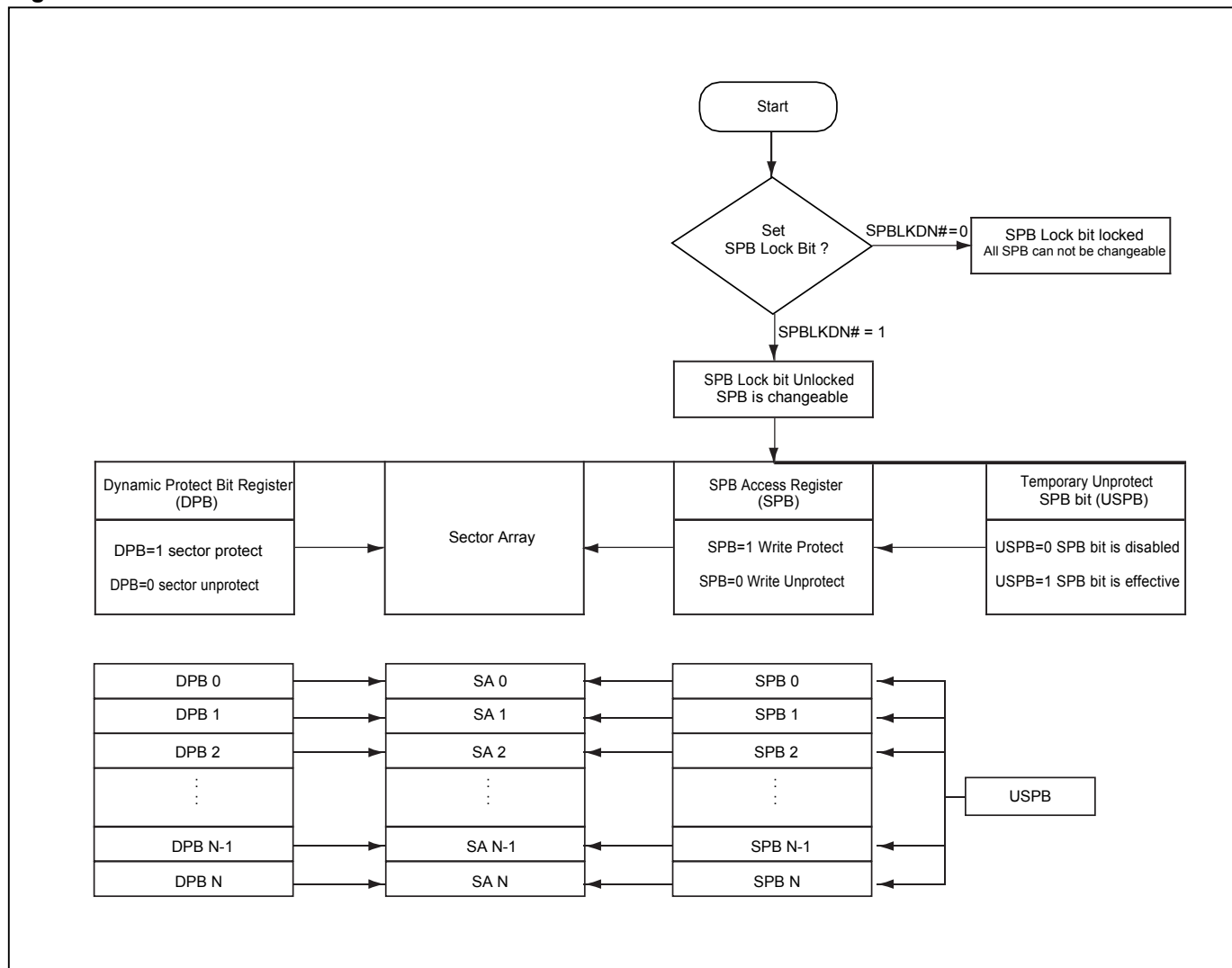

9-36-1. Lock Register

The Lock Register is a 16-bit one-time programmable register. Lock Register bit [6] is SPB Lock Down Bit (SPBLKDN) which is an unique bit assigned to control all SPB bit status.

When SPBLKDN is 1, SPB can be changed. When it is locked as 0, all SPB can not be changed anymore, and SPBLKDN bit itself can not be altered anymore, either.

The Lock Register is programmed using the WRLR (Write Lock Register) command. A WREN command must be executed to set the WEL bit before sending the WRLR command.

Table 13. Lock Register

Bits	Field Name	Function	Type	Default State	Description
15 to 7	RFU	Reserved	OTP	1	Reserved for Future Use
6	SPBLKDN	SPB Lock Down	OTP	1	1 = SPB changeable 0 = freeze SPB
5 to 0	RFU	Reserved	OTP	1	Reserved for Future Use

Figure 75. Read Lock Register (RDLR) Sequence

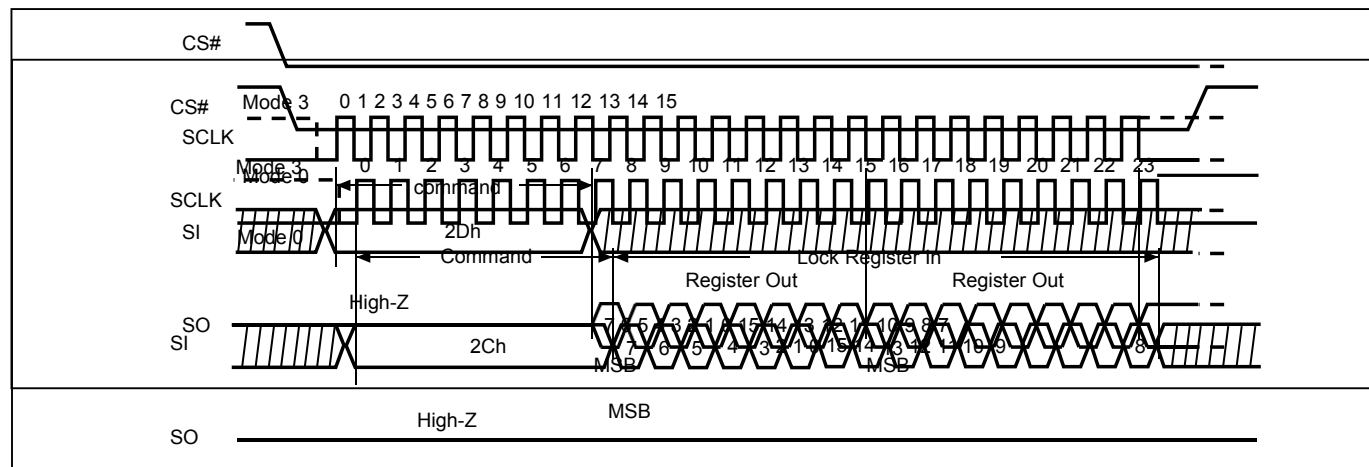

Figure 76. Write Lock Register (WRLR) Sequence



9-36-2. Solid Protection Bits

The Solid Protection Bits (SPBs) are nonvolatile bits for enabling or disabling write-protection to sectors and blocks. The SPB bits have the same endurance as the Flash memory. An SPB is assigned to each 4KB sector in the bottom and top 64KB of memory and to each 64KB block in the remaining memory. The factory default state of the SPB bits is “0”, which has the sector/block write-protection disabled.

When an SPB is set to “1”, the associated sector or block is write-protected. Program and erase operations on the sector or block will be inhibited. SPBs can be individually set to “1” by the WRSPB command. However, the SPBs cannot be individually cleared to “0”. Issuing the ESSPB command clears all SPBs to “0”. A WREN command must be executed to set the WEL bit before sending the WRSPB or ESSPB command.

The RDSPB command reads the status of the SPB of a sector or block. The RDSPB command returns 00h if the SPB is “0”, indicating write-protection is disabled. The RDSPB command returns FFh if the SPB is “1”, indicating write-protection is enabled.

In Solid Protection mode, the Unprotect Solid Protect Bit (USPB) can temporarily mask the SPB bits and disable the write-protection provided by the SPB bits.

Note: If SPBLKDN=0, commands to set or clear the SPB bits will be ignored.

Table 14. SPB Register

Bit	Description	Bit Status	Default	Type
7 to 0	SPB (Solid Protection Bit)	00h = Unprotect Sector / Block FFh = Protect Sector / Block	00h	Non-volatile

Figure 77. Read SPB Status (RDSPB) Sequence

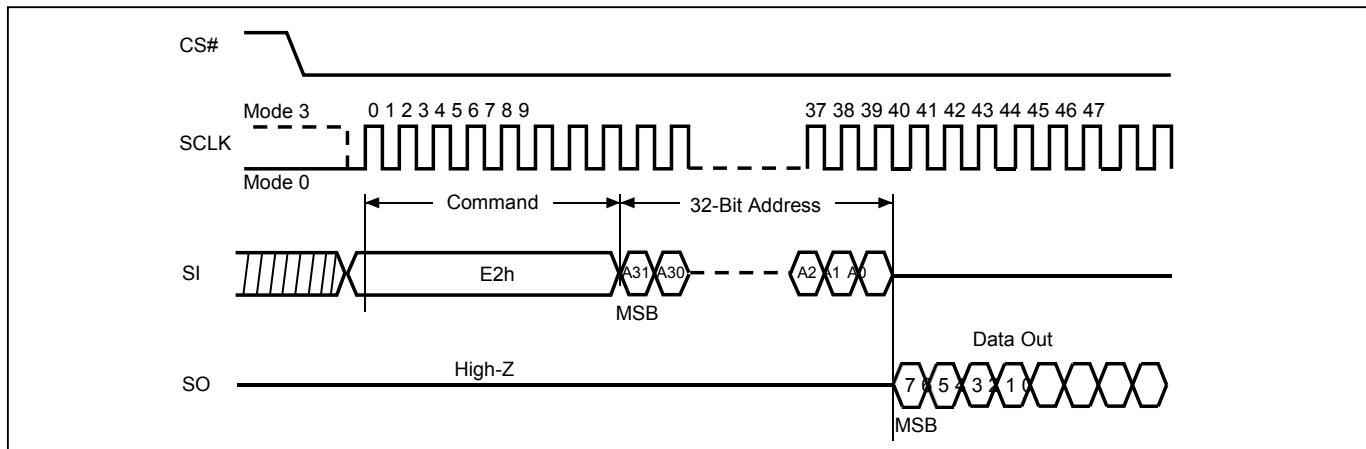

Figure 78. SPB Erase (ESSPB) Sequence

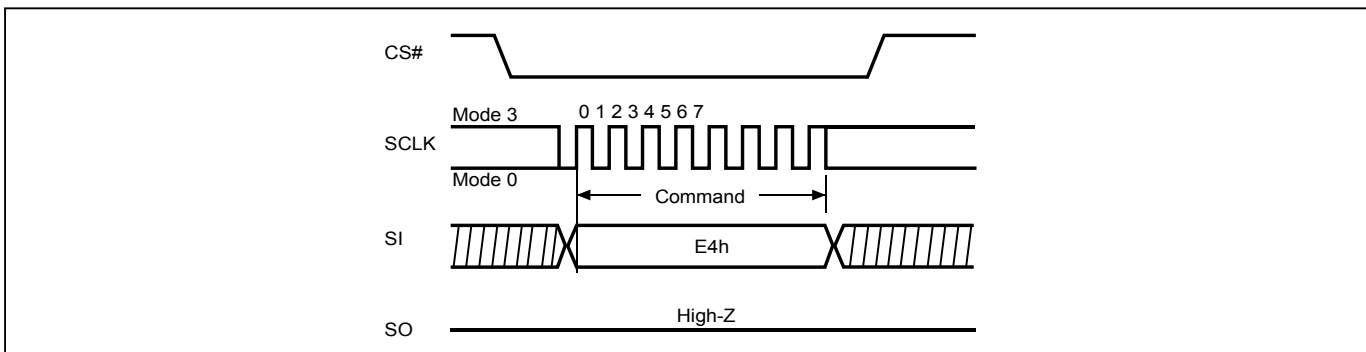
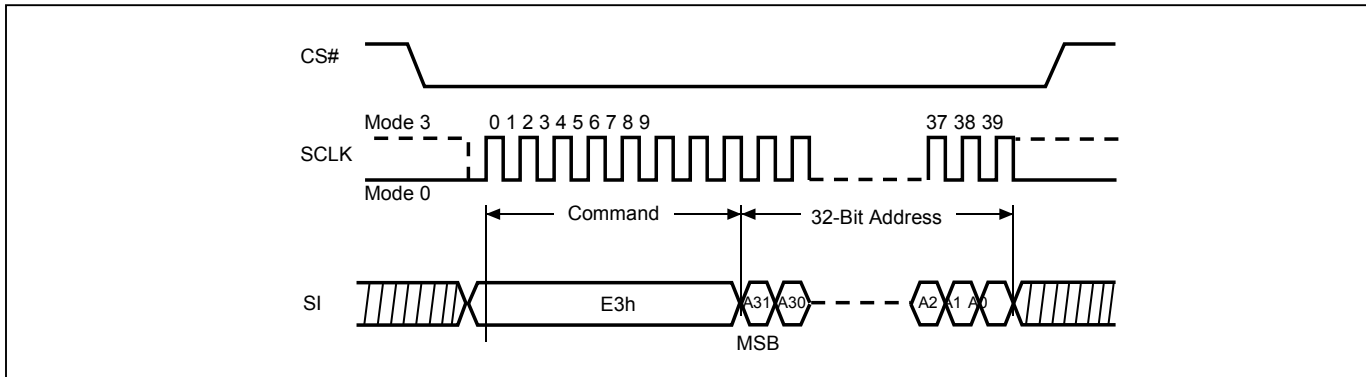

Figure 79. SPB Program (WRSPB) Sequence



9-36-3. Dynamic Protection Bits

The Dynamic Protection Bits (DPBs) are volatile bits for quickly and easily enabling or disabling write-protection to sectors and blocks. A DPB is assigned to each 4KB sector in the bottom and top 64KB of memory and to each 64KB block in the rest of the memory. The DBPs can enable write-protection on a sector or block regardless of the state of the corresponding SPB. However, the DPB bits can only unprotect sectors or blocks whose SPB bits are “0” (unprotected).

When a DPB is “1”, the associated sector or block will be write-protected, preventing any program or erase operation on the sector or block. All DPBs default to “1” after power-on or reset. When a DPB is cleared to “0”, the associated sector or block will be unprotected if the corresponding SPB is also “0”.

DPB bits can be individually set to “1” or “0” by the WRDPB command. The DBP bits can also be globally cleared to “0” with the GBULK command or globally set to “1” with the GBLK command. A WREN command must be executed to set the WEL bit before sending the WRDPB, GBULK, or GBLK command.

The RDDPB command reads the status of the DPB of a sector or block. The RDDPB command returns 00h if the DPB is “0”, indicating write-protection is disabled. The RDDPB command returns FFh if the DPB is “1”, indicating write-protection is enabled.

Table 15. DPB Register

Bit	Description	Bit Status	Default	Type
7 to 0	DPB (Dynamic Protection Bit)	00h = Unprotect Sector / Block FFh = Protect Sector / Block	FFh	Volatile

Figure 80. Read DPB Register (RDDPB) Sequence

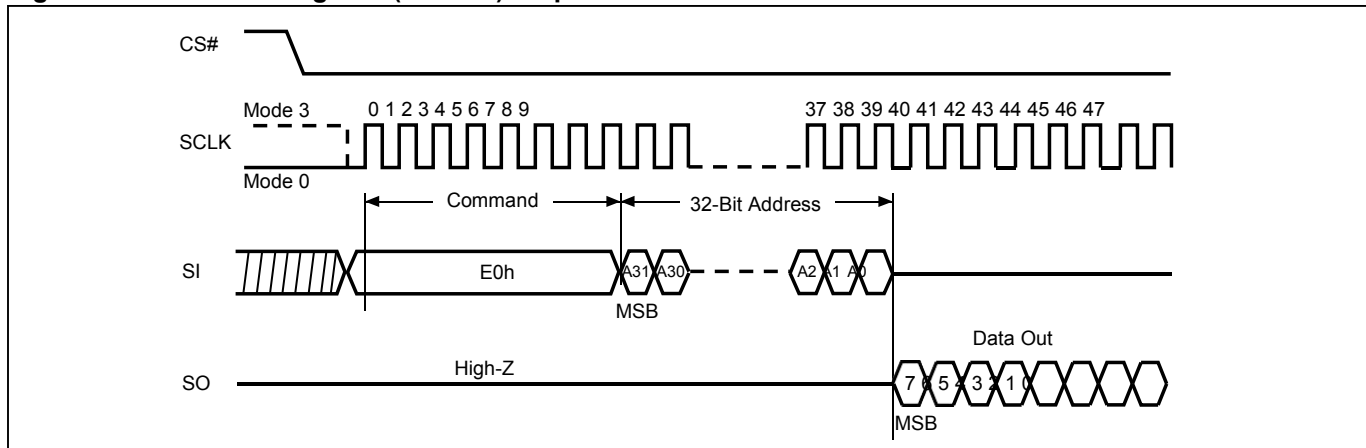
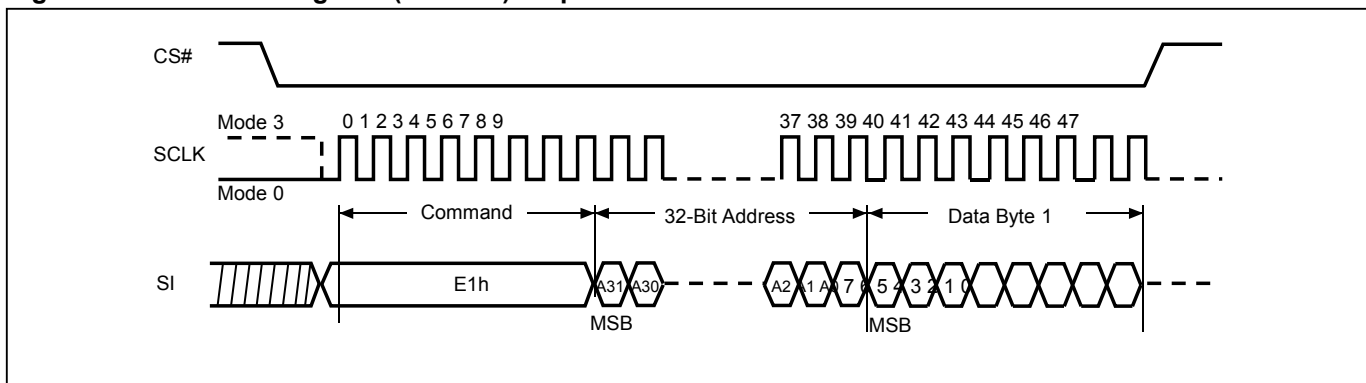

Figure 81. Write DPB Register (WRDPB) Sequence





9-36-4. Unprotect Solid Protect Bit (USPB)

The Unprotect Solid Protect Bit is a volatile bit that defaults to “1” after power-on or reset. When USPB=1, the SPBs have their normal function. When USPB=0 all SPBs are masked and their write-protected sectors and blocks are temporarily unprotected (as long as their corresponding DPBs are “0”). The USPB provides a means to temporarily override the SPBs without having to issue the ESSPB and WRSPB commands to clear and set the SPBs. The USPB can be set or cleared as often as needed.

Please refer to ["9-36-6. Sector Protection States Summary Table"](#) for the sector state with the protection status of DPB/SPB/USPB bits.

9-36-5. Gang Block Lock/Unlock (GBLK/GBULK)

These instructions are only effective if WPSEL=1. The GBLK and GBULK instructions provide a quick method to set or clear all DPB bits at once.

The WREN (Write Enable) instruction is required before issuing the GBLK/GBULK instruction. The sequence of issuing GBLK/GBULK instruction is: CS# goes low → send GBLK/GBULK (7Eh/98h) instruction → CS# goes high.

The CS# must go high exactly at the byte boundary, otherwise, the instruction will be rejected and not be executed.

9-36-6. Sector Protection States Summary Table

DPB	SPB	USPB	Sector/Block Protection State
0	0	0	Unprotected
0	0	1	Unprotected
0	1	0	Unprotected
0	1	1	Protected
1	0	0	Protected
1	0	1	Protected
1	1	0	Protected
1	1	1	Protected



9-37. Program/Erase Suspend/Resume

The device allow the interruption of Sector-Erase, Block-Erase or Page-Program operations and conduct other operations.

After issue suspend command, the system can determine if the device has entered the Erase-Suspended mode through Bit2 (PSB) and Bit3 (ESB) of security register. (please refer to "[Table 12. Security Register Definition](#)")

Both SPI (8 clocks) and QPI (2 clocks) command cycle can accept by this instruction. The SIO[3:1] are don't care when during SPI mode.

9-38. Erase Suspend

Erase suspend allow the interruption of all erase operations. After the device has entered Erase-Suspended mode, the system can read any sector(s) or Block(s) except those being erased by the suspended erase operation. Reading the sector or Block being erase suspended is invalid.

After erase suspend, WEL bit will be clear, only read related, resume and reset command can be accepted, including: 03h, 0Bh, 3Bh, 6Bh, BBh, EBh, 5Ah, C0h, 06h, 04h, 2Bh, 9Fh, AFh, 05h, ABh, 90h, B1h, C1h, B0h, 30h, 66h, 99h, 00h, 35h, F5h, 15h, 2Dh, E2h, E0h.

If the system issues an Erase Suspend command after the sector erase operation has already begun, the device will not enter Erase-Suspended mode until tESL time has elapsed.

Erase Suspend Bit (ESB) indicates the status of Erase Suspend operation. Users may use ESB to identify the state of flash memory. After the flash memory is suspended by Erase Suspend command, ESB is set to "1". ESB is cleared to "0" after erase operation resumes.

9-39. Program Suspend

Program suspend allows the interruption of all program operations. After the device has entered Program-Suspended mode, the system can read any sector(s) or Block(s) except those being programmed by the suspended program operation. Reading the sector or Block being program suspended is invalid.

After program suspend, WEL bit will be cleared, only read related, resume and reset command can be accepted, including: 03h, 0Bh, 3Bh, 6Bh, BBh, EBh, 5Ah, C0h, 06h, 04h, 2Bh, 9Fh, AFh, 05h, ABh, 90h, B1h, C1h, B0h, 30h, 66h, 99h, 00h, 35h, F5h, 15h, 2Dh, E2h, E0h.

Program Suspend Bit (PSB) indicates the status of Program Suspend operation. Users may use PSB to identify the state of flash memory. After the flash memory is suspended by Program Suspend command, PSB is set to "1". PSB is cleared to "0" after program operation resumes.

Figure 82. Suspend to Read Latency

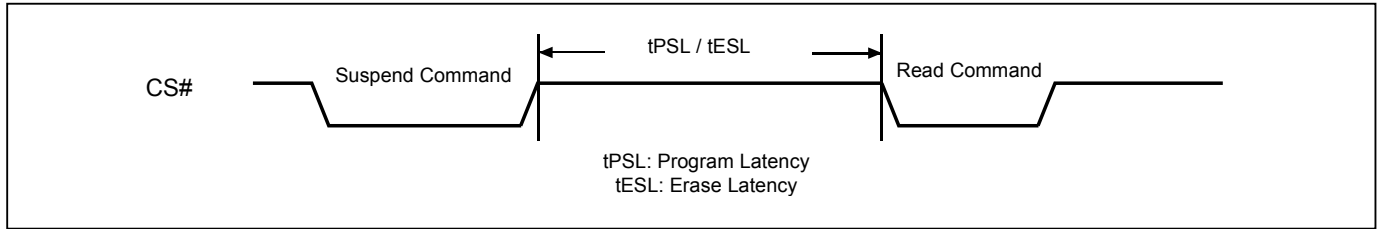

Figure 83. Resume to Read Latency

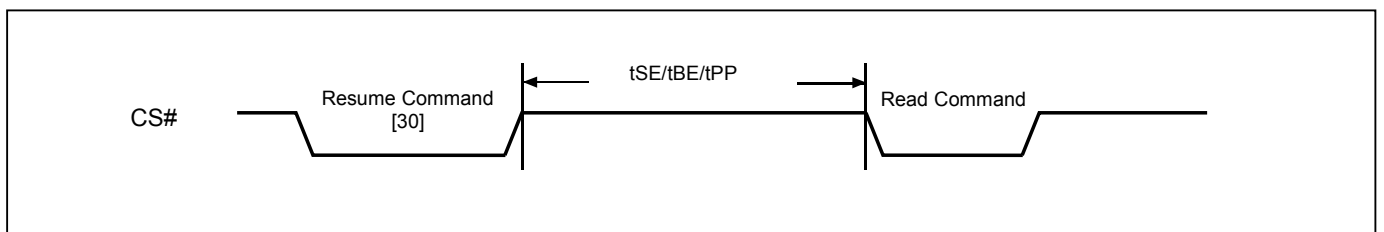
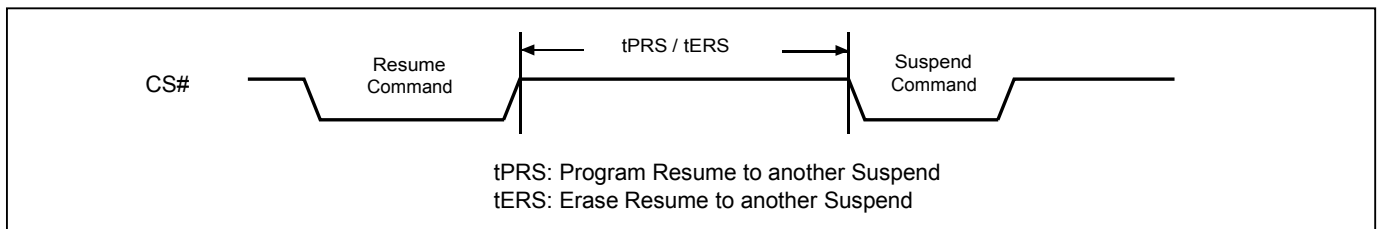

Figure 84. Resume to Suspend Latency





9-40. Write-Resume

The Write operation is being resumed when Write-Resume instruction issued. ESB or PSB (suspend status bit) in Status register will be changed back to “0”.

The operation of Write-Resume is as follows: CS# drives low → send write resume command cycle (30H) → drive CS# high. By polling Busy Bit in status register, the internal write operation status could be checked to be completed or not. The user may also wait the time lag of TSE, TBE, TPP for Sector-erase, Block-erase or Page-programming. WREN (command "06h") is not required to issue before resume. Resume to another suspend operation requires latency time of tPRS or tERS, as defined in "[Table 25. AC CHARACTERISTICS \(Temperature = -40°C to 85°C, VCC = 2.7V - 3.6V\)](#)".

Please note that, if "performance enhance mode" is executed during suspend operation, the device can not be resumed. To restart the write command, disable the "performance enhance mode" is required. After the "performance enhance mode" is disabled, the write-resume command is effective.

9-41. No Operation (NOP)

The “No Operation” command is only able to terminate the Reset Enable (RSTEN) command and will not affect any other command.

Both SPI (8 clocks) and QPI (2 clocks) command cycle can accept by this instruction. The SIO[3:1] are don't care during SPI mode.

9-42. Software Reset (Reset-Enable (RSTEN) and Reset (RST))

The Software Reset operation combines two instructions: Reset-Enable (RSTEN) command and Reset (RST) command. It returns the device to standby mode. All the volatile bits and settings will be cleared then, which makes the device return to the default status as power on.

To execute Reset command (RST), the Reset-Enable (RSTEN) command must be executed first to perform the Reset operation. If there is any other command to interrupt after the Reset-Enable command, the Reset-Enable will be invalid.

Both SPI (8 clocks) and QPI (2 clocks) command cycle can accept by this instruction. The SIO[3:1] are don't care when during SPI mode.

If the Reset command is executed during program or erase operation, the operation will be disabled, the data under processing could be damaged or lost.

The reset time is different depending on the last operation. For details, please refer to "[Table 21. Reset Timing-\(Other Operation\)](#)" for tREADY2.

Figure 85. Software Reset Recovery

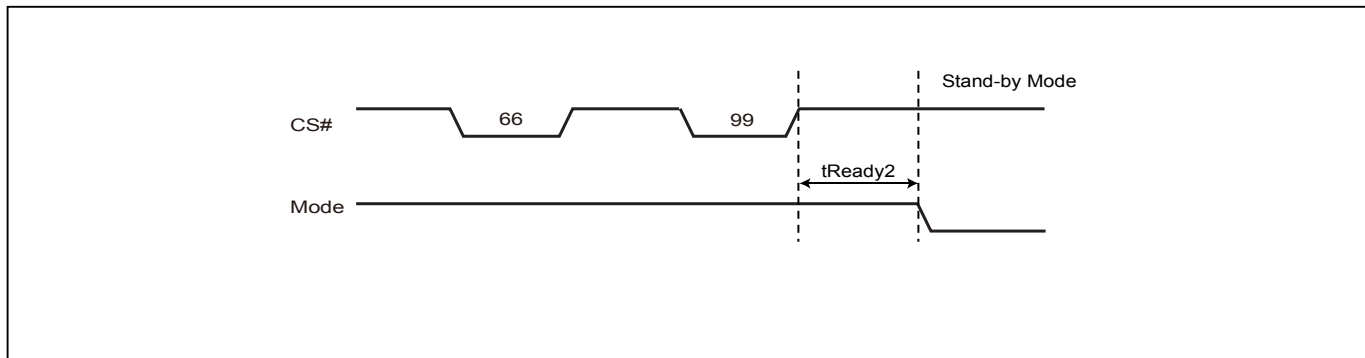

Note: Refer to "Table 21. Reset Timing-(Other Operation)" for t_{READY2} data.

Figure 86. Reset Sequence (SPI mode)

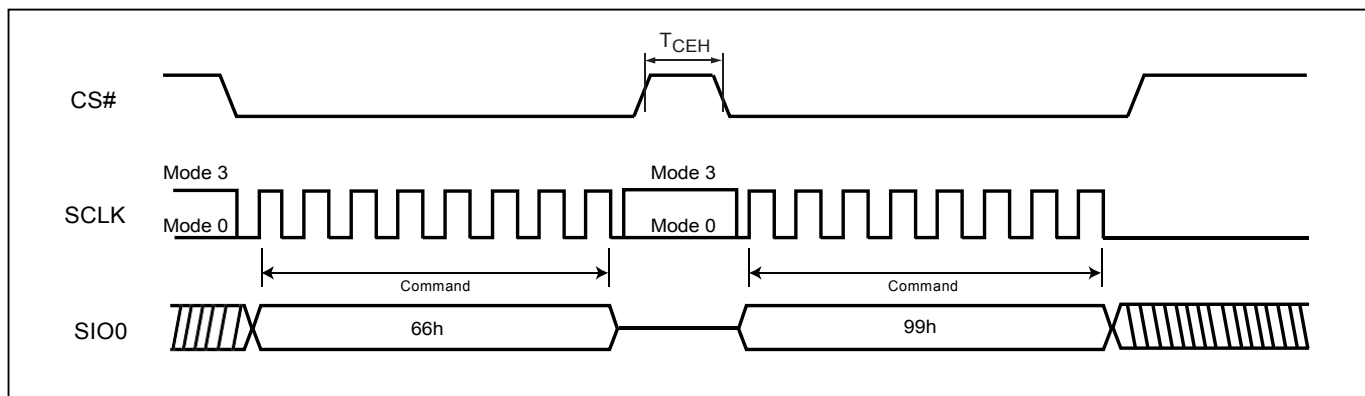
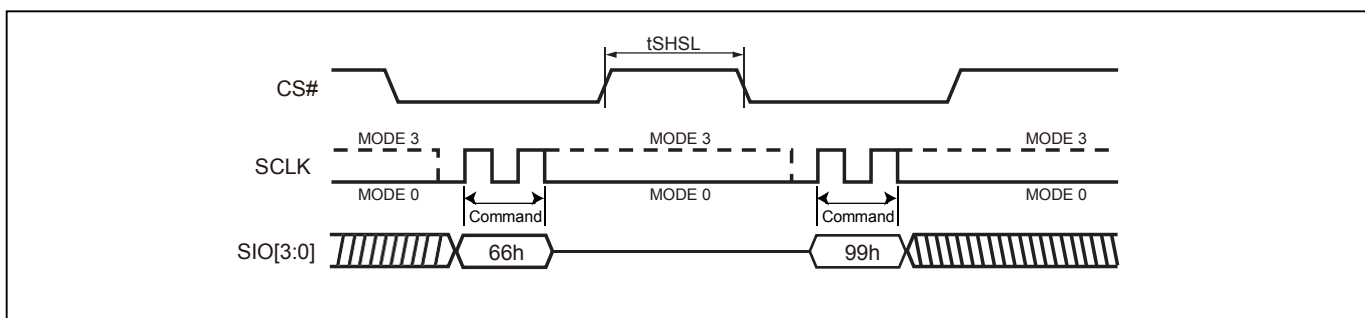

Figure 87. Reset Sequence (QPI mode)



9-43. Read SFDP Mode (RDSFDP)

The Serial Flash Discoverable Parameter (SFDP) standard provides a consistent method of describing the functional and feature capabilities of serial flash devices in a standard set of internal parameter tables. These parameter tables can be interrogated by host system software to enable adjustments needed to accommodate divergent features from multiple vendors. The concept is similar to the one found in the Introduction of JEDEC Standard, JESD68 on CFI.

The sequence of issuing RDSFDP instruction is CS# goes low→send RDSFDP instruction (5Ah)→send 3 address bytes on SI pin→send 1 dummy byte on SI pin→read SFDP code on SO→to end RDSFDP operation can use CS# to high at any time during data out.

SFDP is a JEDEC standard, JESD216B.

Figure 88. Read Serial Flash Discoverable Parameter (RDSFDP) Sequence

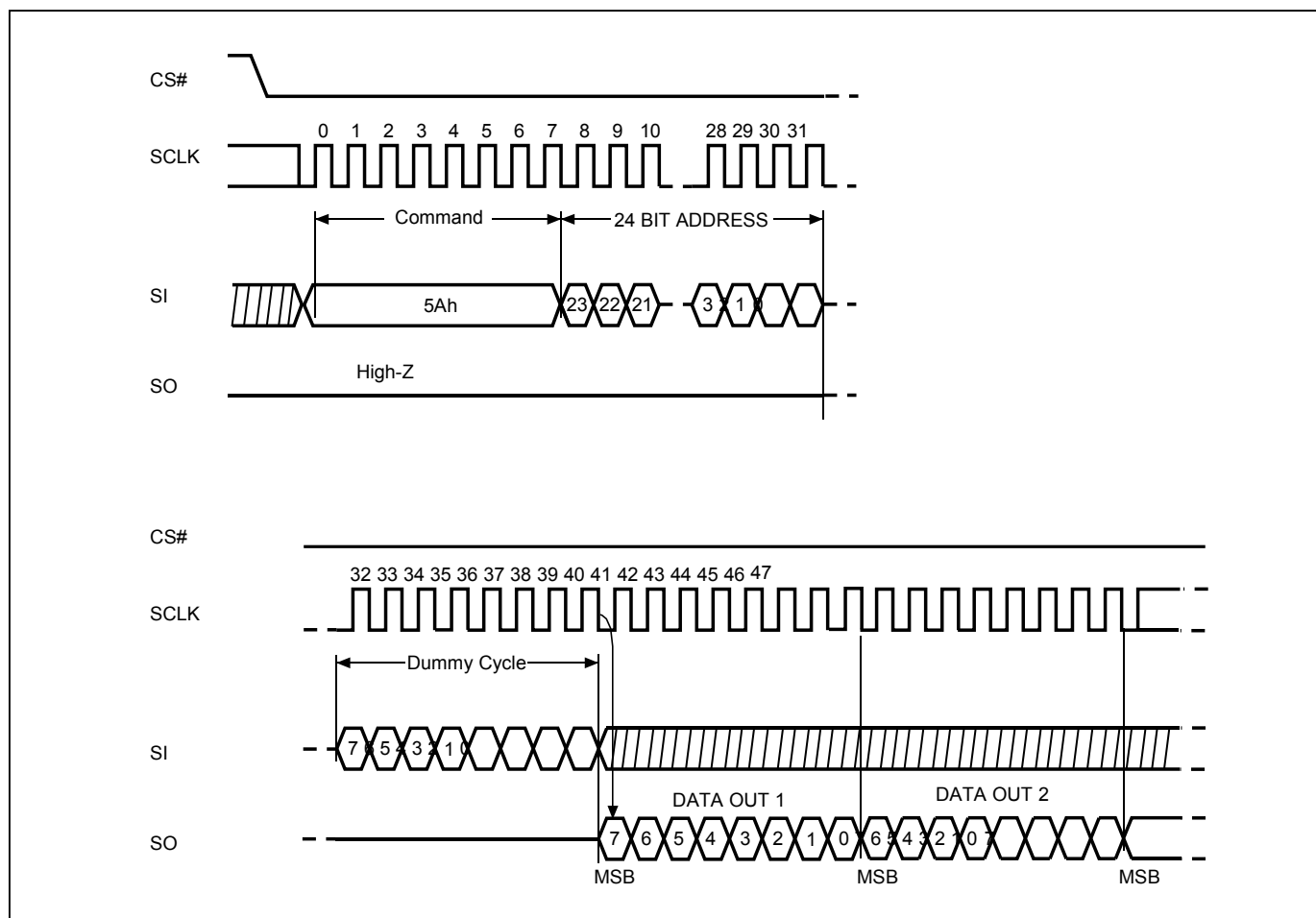



Table 16. Signature and Parameter Identification Data Values

SFDP Table (JESD216B) below is for MX25L25673GM2I-10G, MX25L25673GMI-10G, MX25L25673GM2I-08G, MX25L25673GMI-08G, MX25L25673GZNI-08G, MX25L25673GZ4I-08G and MX25L25673GZNI-10G

Description	Comment	Add (h) (Byte)	DW Add (Bit)	Data (h/b) (Note1)	Data (h)
SFDP Signature	Fixed: 50444653h	00h	07:00	53h	53h
		01h	15:08	46h	46h
		02h	23:16	44h	44h
		03h	31:24	50h	50h
SFDP Minor Revision Number	Start from 00h	04h	07:00	06h	06h
SFDP Major Revision Number	Start from 01h	05h	15:08	01h	01h
Number of Parameter Headers	This number is 0-based. Therefore, 0 indicates 1 parameter header.	06h	23:16	02h	02h
Unused		07h	31:24	FFh	FFh
ID number (JEDEC)	00h: it indicates a JEDEC specified header.	08h	07:00	00h	00h
Parameter Table Minor Revision Number	Start from 00h	09h	15:08	06h	06h
Parameter Table Major Revision Number	Start from 01h	0Ah	23:16	01h	01h
Parameter Table Length (in double word)	How many DWORDs in the Parameter table	0Bh	31:24	10h	10h
Parameter Table Pointer (PTP)	First address of JEDEC Flash Parameter table	0Ch	07:00	30h	30h
		0Dh	15:08	00h	00h
		0Eh	23:16	00h	00h
Unused		0Fh	31:24	FFh	FFh



MX25L25673G

SFDP Table below is for MX25L25673GM2I-10G, MX25L25673GMI-10G, MX25L25673GM2I-08G, MX25L25673GMI-08G, MX25L25673GZNI-08G, MX25L25673GZ4I-08G and MX25L25673GZNI-10G

Description	Comment	Add (h) (Byte)	DW Add (Bit)	Data (h/b) (Note1)	Data (h)
ID number (Macronix manufacturer ID)	it indicates Macronix manufacturer ID	10h	07:00	C2h	C2h
Parameter Table Minor Revision Number	Start from 00h	11h	15:08	00h	00h
Parameter Table Major Revision Number	Start from 01h	12h	23:16	01h	01h
Parameter Table Length (in double word)	How many DWORDs in the Parameter table	13h	31:24	04h	04h
Parameter Table Pointer (PTP)	First address of Macronix Flash Parameter table	14h	07:00	10h	10h
		15h	15:08	01h	01h
		16h	23:16	00h	00h
Unused		17h	31:24	FFh	FFh
ID number (4-byte Address Instruction)	4-byte Address Instruction parameter ID	18h	07:00	84h	84h
Parameter Table Minor Revision Number	Start from 00h	19h	15:08	00h	00h
Parameter Table Major Revision Number	Start from 01h	1Ah	23:16	01h	01h
Parameter Table Length (in double word)	How many DWORDs in the Parameter table	1Bh	31:24	02h	02h
Parameter Table Pointer (PTP)	First address of 4-byte Address Instruction table	1Ch	07:00	C0h	C0h
		1Dh	15:08	00h	00h
		1Eh	23:16	00h	00h
Unused		1Fh	31:24	FFh	FFh



Table 17. Parameter Table (0): JEDEC Flash Parameter Tables

SFDP Table below is for MX25L25673GM2I-10G, MX25L25673GMI-10G, MX25L25673GM2I-08G, MX25L25673GMI-08G, MX25L25673GZNI-08G, MX25L25673GZ4I-08G and MX25L25673GZNI-10G

Description	Comment	Add (h) (Byte)	DW Add (Bit)	Data (h/b) (Note1)	Data (h)
Block/Sector Erase sizes	00: Reserved, 01: 4KB erase, 10: Reserved, 11: not supported 4KB erase	30h	01:00	01b	E5h
Write Granularity	0: 1Byte, 1: 64Byte or larger		02	1b	
Write Enable Instruction Required for Writing to Volatile Status Registers	0: not required 1: required 00h to be written to the status register		03	0b	
Write Enable Instruction Select for Writing to Volatile Status Registers	0: use 50h instruction 1: use 06h instruction Note: If target flash status register is nonvolatile, then bits 3 and 4 must be set to 00b.		04	0b	
Unused	Contains 111b and can never be changed		07:05	111b	
4KB Erase Instruction		31h	15:08	20h	20h
(1-1-2) Fast Read (Note2)	0=not supported 1=supported	32h	16	1b	FBh
Address Bytes Number used in addressing flash array	00: 3Byte only, 01: 3 or 4Byte, 10: 4Byte only, 11: Reserved		18:17	01b	
Double Transfer Rate (DTR) Clocking	0=not supported 1=supported		19	1b	
(1-2-2) Fast Read	0=not supported 1=supported		20	1b	
(1-4-4) Fast Read	0=not supported 1=supported		21	1b	
(1-1-4) Fast Read	0=not supported 1=supported		22	1b	
Unused			23	1b	
Unused		33h	31:24	FFh	FFh
Flash Memory Density		37h:34h	31:00	0FFF FFFFh	
(1-4-4) Fast Read Number of Wait states (Note3)	0 0000b: Not supported; 0 0100b: 4 0 0110b: 6; 0 1000b: 8	38h	04:00	0 0100b	44h
(1-4-4) Fast Read Number of Mode Bits (Note4)	Mode Bits: 000b: Not supported; 010b: 2 bits		07:05	010b	
(1-4-4) Fast Read Instruction		39h	15:08	EBh	EBh
(1-1-4) Fast Read Number of Wait states	0 0000b: Not supported; 0 0100b: 4 0 0110b: 6; 0 1000b: 8	3Ah	20:16	0 1000b	08h
(1-1-4) Fast Read Number of Mode Bits	Mode Bits: 000b: Not supported; 010b: 2 bits		23:21	000b	
(1-1-4) Fast Read Instruction		3Bh	31:24	6Bh	6Bh



MX25L25673G

SFDP Table below is for MX25L25673GM2I-10G, MX25L25673GMI-10G, MX25L25673GM2I-08G, MX25L25673GMI-08G, MX25L25673GZNI-08G, MX25L25673GZ4I-08G and MX25L25673GZNI-10G

Description	Comment	Add (h) (Byte)	DW Add (Bit)	Data (h/b) (Note1)	Data (h)
(1-1-2) Fast Read Number of Wait states	0 0000b: Not supported; 0 0100b: 4 0 0110b: 6; 0 1000b: 8	3Ch	04:00	0 1000b	08h
(1-1-2) Fast Read Number of Mode Bits	Mode Bits: 000b: Not supported; 010b: 2 bits		07:05	000b	
(1-1-2) Fast Read Instruction		3Dh	15:08	3Bh	3Bh
(1-2-2) Fast Read Number of Wait states	0 0000b: Not supported; 0 0100b: 4 0 0110b: 6; 0 1000b: 8	3Eh	20:16	0 0100b	04h
(1-2-2) Fast Read Number of Mode Bits	Mode Bits: 000b: Not supported; 010b: 2 bits		23:21	000b	
(1-2-2) Fast Read Instruction		3Fh	31:24	BBh	BBh
(2-2-2) Fast Read	0=not supported 1=supported	40h	00	0b	FEh
Unused			03:01	111b	
(4-4-4) Fast Read	0=not supported 1=supported		04	1b	
Unused			07:05	111b	
Unused		43h:41h	31:08	FFh	FFh
Unused		45h:44h	15:00	FFh	FFh
(2-2-2) Fast Read Number of Wait states	0 0000b: Not supported; 0 0100b: 4 0 0110b: 6; 0 1000b: 8	46h	20:16	0 0000b	00h
(2-2-2) Fast Read Number of Mode Bits	Mode Bits: 000b: Not supported; 010b: 2 bits		23:21	000b	
(2-2-2) Fast Read Instruction		47h	31:24	FFh	FFh
Unused		49h:48h	15:00	FFh	FFh
(4-4-4) Fast Read Number of Wait states	0 0000b: Not supported; 0 0100b: 4 0 0110b: 6; 0 1000b: 8	4Ah	20:16	0 0100b	44h
(4-4-4) Fast Read Number of Mode Bits	Mode Bits: 000b: Not supported; 010b: 2 bits		23:21	010b	
(4-4-4) Fast Read Instruction		4Bh	31:24	EBh	EBh
Erase Type 1 Size	Sector/block size = 2 ^N bytes (Note5) 0Ch: 4KB; 0Fh: 32KB; 10h: 64KB	4Ch	07:00	0Ch	0Ch
Erase Type 1 Erase Instruction		4Dh	15:08	20h	20h
Erase Type 2 Size	Sector/block size = 2 ^N bytes 00h: N/A; 0Fh: 32KB; 10h: 64KB	4Eh	23:16	0Fh	0Fh
Erase Type 2 Erase Instruction		4Fh	31:24	52h	52h
Erase Type 3 Size	Sector/block size = 2 ^N bytes 00h: N/A; 0Fh: 32KB; 10h: 64KB	50h	07:00	10h	10h
Erase Type 3 Erase Instruction		51h	15:08	D8h	D8h
Erase Type 4 Size	00h: N/A, This sector type doesn't exist	52h	23:16	00h	00h
Erase Type 4 Erase Instruction		53h	31:24	FFh	FFh



MX25L25673G

SFDP Table below is for MX25L25673GM2I-10G, MX25L25673GMI-10G, MX25L25673GM2I-08G, MX25L25673GMI-08G, MX25L25673GZNI-08G, MX25L25673GZ4I-08G and MX25L25673GZNI-10G

Description	Comment	Add (h) (Byte)	DW Add (Bit)	Data (h/b) (Note1)	Data (h)
Multiplier from typical erase time to maximum erase time	Multiplier value: 0h~Fh (0~15) Max. time = 2 * (Multiplier + 1) * Typical Time	54h	03:00	0110b	D6h
Erase Type 1 Erase Time (Typical)	Count value: 00h~1Fh (0~31) Typical Time = (Count + 1) * Units	55h	07:04	1 1101b	59h
	Units 00: 1ms, 01: 16ms 10b: 128ms, 11b: 1s		08		
Erase Type 2 Erase Time (Typical)	Count value: 00h~1Fh (0~31) Typical Time = (Count + 1) * Units	56h	15:11	0 1011b	DDh
	Units 00: 1ms, 01: 16ms 10b: 128ms, 11b: 1s		17:16		
Erase Type 3 Erase Time (Typical)	Count value: 00h~1Fh (0~31) Typical Time = (Count + 1) * Units	57h	22:18	1 0111b	00h
	Units 00: 1 ms, 01: 16 ms 10b: 128ms, 11b: 1s		24:23		
Erase Type 4 Erase Time (Typical)	Count value: 00h~1Fh (0~31) Typical Time = (Count + 1) * Units	58h	29:25	0 0000b	82h
	Units 00: 1ms, 01: 16ms 10b: 128 ms, 11b: 1 s		31:30		
Multiplier from typical time to max time for Page or byte program	Multiplier value: 0h~Fh (0~15) Max. time = 2 * (Multiplier + 1) * Typical Time	58h	03:00	0010b	82h
Page Program Size	Page size = 2 ^N bytes 2 ⁸ = 256 bytes, 8h = 1000b		07:04		
Page Program Time (Typical)	Count value: 00h~1Fh (0~31) Typical Time = (Count + 1) * Units	59h	12:08	1 1111b	9Fh
	Units 0: 8us, 1: 64us		13		
Byte Program Time, First Byte (Typical)	Count value: 0h~Fh (0~15) Typical Time = (Count + 1) * Units	5Ah	15:14	1110b	03h
	Units 0: 1us, 1: 8us		17:16		
Byte Program Time, Additional Byte (Typical)	Count value: 0h~Fh (0~15) Typical Time = (Count + 1) * Units	5Ah	18	0000b	03h
	Units 0: 1us, 1: 8us		22:19		
			23		



MX25L25673G

SFDP Table below is for MX25L25673GM2I-10G, MX25L25673GMI-10G, MX25L25673GM2I-08G, MX25L25673GMI-08G, MX25L25673GZNI-08G, MX25L25673GZ4I-08G and MX25L25673GZNI-10G

Description	Comment	Add (h) (Byte)	DW Add (Bit)	Data (h/b) (Note1)	Data (h)
Chip Erase Time (Typical)	Count value: 00h~1Fh (0~31) Typical Time = (Count + 1) * Units	5Bh	27:24	1 1011b	DBh
	Units 00: 16ms, 01: 256ms 10: 4s, 11: 64s		28		
Reserved	Reserved: 1b		30:29	10b	
Reserved	Reserved: 1b		31	1b	
Prohibited Operations During Program Suspend	<ul style="list-style-type: none"> ◆ xxx0b: May not initiate a new erase anywhere ◆ xx0xb: May not initiate a new page program anywhere ◆ x1xxb: May not initiate a read in the program suspended page size ◆ 1xxxb: The erase and program restrictions in bits 1:0 are sufficient 		03:00	0100b	
Prohibited Operations During Erase Suspend	<ul style="list-style-type: none"> ◆ xxx0b: May not initiate a new erase anywhere ◆ xx1xb: May not initiate a page program in the erase suspended sector size ◆ xx0xb: May not initiate a page program anywhere ◆ x1xxb: May not initiate a read in the erase suspended sector size ◆ 1xxxb: The erase and program restrictions in bits 5:4 are sufficient 	5Ch	07:04	0100b	44h
Reserved	Reserved: 1b		08	1b	
Program Resume to Suspend Interval (Typical)	Count value: 0h~Fh (0~15) Typical Time = (Count + 1) * 64us	5Dh	12:09	0001b	03h
Program Suspend Latency (Max.)	Count value: 00h~1Fh (0~31) Maximum Time = (Count + 1) * Units	5Eh	15:13	1 1000b	67h
	Units 00: 128ns, 01: 1us 10: 8us, 11: 64us		17:16		
Erase Resume to Suspend Interval (Typical)	Count value: 0h~Fh (0~15) Typical Time = (Count + 1) * 64us		19:18	01b	
Erase Suspend Latency (Max.)	Count value: 00h~1Fh (0~31) Maximum Time = (Count + 1) * Units	5Fh	23:20	0110b	38h
	Units 00: 128ns, 01: 1us 10: 8us, 11: 64us		28:24	1 1000b	
Suspend / Resume supported	0= Support 1= Not supported		30:29	01b	
Program Resume Instruction	Instruction to Resume a Program	60h	31	0b	
Program Suspend Instruction	Instruction to Suspend a Program	61h	07:00	30h	30h
Erase Resume Instruction	Instruction to Resume Write/Erase	62h	15:08	B0h	B0h
Erase Suspend Instruction	Instruction to Suspend Write/Erase	63h	23:16	30h	30h
			31:24	B0h	B0h



MX25L25673G

SFDP Table below is for MX25L25673GM2I-10G, MX25L25673GMI-10G, MX25L25673GM2I-08G, MX25L25673GMI-08G, MX25L25673GZNI-08G, MX25L25673GZ4I-08G and MX25L25673GZNI-10G

Description	Comment	Add (h) (Byte)	DW Add (Bit)	Data (h/b) (Note1)	Data (h)
Reserved	Reserved: 11b		01:00	11b	
Status Register Polling Device Busy	<ul style="list-style-type: none"> ◆ Bit 2: Read WIP bit [0] by 05h Read instruction ◆ Bit 3: Read bit 7 of Status Register by 70h Read instruction (0=not supported 1=support) ◆ Bit 07:04, Reserved: 1111b 	64h	07:02	11 1101b	F7h
Release from Deep Power-down (RDP) Delay (Max.)	Count value: 00h~1Fh (0~31) Maximum Time = (Count + 1) * Units	65h	12:08	1 1101b	BDh
	Units 00: 128ns, 01: 1us 10: 8us, 11: 64us		14:13	01b	
Release from Deep Power-down (RDP) Instruction	Instruction to Exit Deep Power Down ◆ FFh: Don't need command	66h	15	1010 1011b	D5h
Enter Deep Power Down Instruction	Instruction to Enter Deep Power Down		22:16	(ABh)	
Deep Power Down Supported	0: Supported 1: Not supported	67h	23	1011 1001b	5Ch
			30:24	(B9h)	
4-4-4 Mode Disable Sequences	Methods to exit 4-4-4 mode ◆ xx1xb: issue F5h instruction	68h	31	0b	4Ah
			07:04	0 0100b	
4-4-4 Mode Enable Sequences	Methods to enter 4-4-4 mode ◆ x_x1xxb: issue instruction 35h	69h	08		9Eh
0-4-4 Mode Supported	Performance Enhance Mode, Continuous Read, Execute in Place 0: Not supported 1: Supported		09	1b	
0-4-4 Mode Exit Method	<ul style="list-style-type: none"> ◆ xx_xxx1b: Mode Bits[7:0] = 00h will terminate this mode at the end of the current read operation. ◆ xx_x1xb: If 3-Byte address active, input Fh on DQ0-DQ3 for 8 clocks. If 4-Byte address active, input Fh on DQ0-DQ3 for 10 clocks. ◆ xx_x1xxb: Reserved ◆ xx_1xxxb: Input Fh (mode bit reset) on DQ0-DQ3 for 8 clocks. ◆ x1_xxxxb: Mode Bit[7:0]≠Axh ◆ 1x_xxxxb: Reserved 		15:10	10 0111b	
0-4-4 Mode Entry Method	<ul style="list-style-type: none"> ◆ xxx1b: Mode Bits[7:0] = A5h Note: QE must be set prior to using this mode ◆ x1xxb: Mode Bit[7:0]=Axh ◆ 1xxxb: Reserved 		19:16	1001h	
Quad Enable (QE) bit Requirements	<ul style="list-style-type: none"> ◆ 000b: No QE bit. Detects 1-1-4/1-4-4 reads based on instruction ◆ 010b: QE is bit 6 of Status Register, where 1=Quad Enable or 0=not Quad Enable ◆ 111b: Not Supported 	6Ah	22:20	010b	29h
HOLD and RESET Disable by bit 4 of Ext. Configuration Register	0: Not supported		23	0b	



MX25L25673G

SFDP Table below is for MX25L25673GM2I-10G, MX25L25673GMI-10G, MX25L25673GM2I-08G, MX25L25673GMI-08G, MX25L25673GZNI-08G, MX25L25673GZ4I-08G and MX25L25673GZNI-10G

Description	Comment	Add (h) (Byte)	DW Add (Bit)	Data (h/b) (Note1)	Data (h)
Reserved		6Bh	31:24	FFh	FFh
Volatile or Non-Volatile Register and Write Enable Instruction for Status Register 1	<ul style="list-style-type: none"> ◆ xxx_xxx1b: Non-Volatile Status Register 1, powers-up to last written value, use instruction 06h to enable write ◆ x1x_xxxxb: Reserved ◆ 1xx_xxxxb: Reserved 	6Ch	06:00	111 0000b	F0h
			07	1b	
Soft Reset and Rescue Sequence Support	Return the device to its default power-on state <ul style="list-style-type: none"> ◆ x1_xxxxb: issue reset enable instruction 66h, then issue reset instruction 99h. 	6Dh	13:08	01 0000b	50h
Exit 4-Byte Addressing	<ul style="list-style-type: none"> ◆ xx_xxxx_xxx1b: issue instruction E9h to exit 4-Byte address mode (write enable instruction 06h is not required) ◆ xx_xxxx_x1xxb: 8-bit volatile extended address register used to define A[31:A24] bits. Read with instruction C8h. Write instruction is C5h, data length is 1 byte. Return to lowest memory segment by setting A[31:24] to 00h and use 3-Byte addressing. ◆ xx_xx1x_xxxxb: Hardware reset ◆ xx_x1xx_xxxxb: Software reset (see bits 13:8 in this DWORD) ◆ xx_1xxx_xxxxb: Power cycle ◆ x1_xxxx_xxxxb: Reserved ◆ 1x_xxxx_xxxxb: Reserved 		15:14	01b	
				6Eh	23:16



MX25L25673G

SFDP Table below is for MX25L25673GM2I-10G, MX25L25673GMI-10G, MX25L25673GM2I-08G, MX25L25673GMI-08G, MX25L25673GZNI-08G, MX25L25673GZ4I-08G and MX25L25673GZNI-10G

Description	Comment	Add (h) (Byte)	DW Add (Bit)	Data (h/b) (Note1)	Data (h)
Enter 4-Byte Addressing	<ul style="list-style-type: none"> ◆ xxxx_xxx1b: issue instruction B7h (preceding write enable not required) ◆ xxxx_x1xxb: 8-bit volatile extended address register used to define A[31:24] bits. Read with instruction C8h. Write instruction is C5h with 1 byte of data. Select the active 128 Mbit memory segment by setting the appropriate A[31:24] bits and use 3-Byte addressing. ◆ xx1x_xxxxb: Supports dedicated 4-Byte address instruction set. Consult vendor data sheet for the instruction set definition. ◆ 1xxx_xxxxb: Reserved 	6Fh	31:24	1000 0101b	85h



Table 18. Parameter Table (1): 4-Byte Instruction Tables

SFDP Table below is for MX25L25673GM2I-10G, MX25L25673GMI-10G, MX25L25673GM2I-08G, MX25L25673GMI-08G, MX25L25673GZNI-08G, MX25L25673GZ4I-08G and MX25L25673GZNI-10G

Description	Comment	Add (h) (Byte)	DW Add (Bit)	Data (h/b) (Note1)	Data (h)
Support for (1-1-1) READ Command, Instruction=13h	0=not supported 1=supported	C0h	00	1b	7Fh
Support for (1-1-1) FAST_READ Command, Instruction=0Ch	0=not supported 1=supported		01	1b	
Support for (1-1-2) FAST_READ Command, Instruction=3Ch	0=not supported 1=supported		02	1b	
Support for (1-2-2) FAST_READ Command, Instruction=BCh	0=not supported 1=supported		03	1b	
Support for (1-1-4) FAST_READ Command, Instruction=6Ch	0=not supported 1=supported		04	1b	
Support for (1-4-4) FAST_READ Command, Instruction=ECh	0=not supported 1=supported		05	1b	
Support for (1-1-1) Page Program Command, Instruction=12h	0=not supported 1=supported		06	1b	
Support for (1-1-4) Page Program Command, Instruction=34h	0=not supported 1=supported		07	0b	
Support for (1-4-4) Page Program Command, Instruction=3Eh	0=not supported 1=supported	C1h	08	1b	8Fh
Support for Erase Command – Type 1 size, Instruction lookup in next Dword	0=not supported 1=supported		09	1b	
Support for Erase Command – Type 2 size, Instruction lookup in next Dword	0=not supported 1=supported		10	1b	
Support for Erase Command – Type 3 size, Instruction lookup in next Dword	0=not supported 1=supported		11	1b	
Support for Erase Command – Type 4 size, Instruction lookup in next Dword	0=not supported 1=supported		12	0b	
Support for (1-1-1) DTR_Read Command, Instruction=0Eh	0=not supported 1=supported		13	0b	
Support for (1-2-2) DTR_Read Command, Instruction=BEh	0=not supported 1=supported		14	0b	
Support for (1-4-4) DTR_Read Command, Instruction=EEh	0=not supported 1=supported		15	1b	



MX25L25673G

SFDP Table below is for MX25L25673GM2I-10G, MX25L25673GMI-10G, MX25L25673GM2I-08G, MX25L25673GMI-08G, MX25L25673GZNI-08G, MX25L25673GZ4I-08G and MX25L25673GZNI-10G

Description	Comment	Add (h) (Byte)	DW Add (Bit)	Data (h/b) (Note1)	Data (h)
Support for volatile individual sector lock Read command, Instruction=E0h	0=not supported 1=supported	C2h	16	1b	FFh
Support for volatile individual sector lock Write command, Instruction=E1h	0=not supported 1=supported		17	1b	
Support for non-volatile individual sector lock read command, Instruction=E2h	0=not supported 1=supported		18	1b	
Support for non-volatile individual sector lock write command, Instruction=E3h	0=not supported 1=supported		19	1b	
Reserved	Reserved		23:20	1111b	
Reserved	Reserved	C3h	31:24	FFh	FFh
Instruction for Erase Type 1	FFh=not supported	C4h	07:00	21h	21h
Instruction for Erase Type 2	FFh=not supported	C5h	15:08	5Ch	5Ch
Instruction for Erase Type 3	FFh=not supported	C6h	23:16	DCh	DCh
Instruction for Erase Type 4	FFh=not supported	C7h	31:24	FFh	FFh



MX25L25673G

Table 19. Parameter Table (2): Macronix Flash Parameter Tables

SFDP Table below is for MX25L25673GM2I-10G, MX25L25673GMI-10G, MX25L25673GM2I-08G, MX25L25673GMI-08G, MX25L25673GZNI-08G, MX25L25673GZ4I-08G and MX25L25673GZNI-10G

Description	Comment	Add (h) (Byte)	DW Add (Bit)	Data (h/b) (Note1)	Data (h)
Vcc Supply Maximum Voltage	2000h=2.000V 2700h=2.700V 3600h=3.600V	111h:110h	07:00 15:08	00h 36h	00h 36h
Vcc Supply Minimum Voltage	1650h=1.650V, 1750h=1.750V 2250h=2.250V, 2300h=2.300V 2350h=2.350V, 2650h=2.650V 2700h=2.700V	113h: 112h	23:16 31:24	00h 27h	00h 27h
H/W Reset# pin	0=not supported 1=supported	115h: 114h	00	1b	F99Dh
H/W Hold# pin	0=not supported 1=supported		01	0b	
Deep Power Down Mode	0=not supported 1=supported		02	1b	
S/W Reset	0=not supported 1=supported		03	1b	
S/W Reset Instruction	Reset Enable (66h) should be issued before Reset Instruction		11:04	1001 1001b (99h)	
Program Suspend/Resume	0=not supported 1=supported		12	1b	
Erase Suspend/Resume	0=not supported 1=supported		13	1b	
Unused			14	1b	
Wrap-Around Read mode	0=not supported 1=supported		15	1b	
Wrap-Around Read mode Instruction		116h	23:16	C0h	C0h
Wrap-Around Read data length	08h:support 8B wrap-around read 16h:8B&16B 32h:8B&16B&32B 64h:8B&16B&32B&64B	117h	31:24	64h	64h
Individual block lock	0=not supported 1=supported	11Bh: 118h	00	1b	CB85h
Individual block lock bit (Volatile/Nonvolatile)	0=Volatile 1=Nonvolatile		01	0b	
Individual block lock Instruction			09:02	1110 0001b (E1h)	
Individual block lock Volatile protect bit default protect status	0=protect 1=unprotect		10	0b	
Secured OTP	0=not supported 1=supported		11	1b	
Read Lock	0=not supported 1=supported		12	0b	
Permanent Lock	0=not supported 1=supported		13	0b	
Unused			15:14	11b	
Unused			31:16	FFh	
Unused		11Fh: 11Ch	31:00	FFh	FFh



Note 1: h/b is hexadecimal or binary.

Note 2: **(x-y-z)** means I/O mode nomenclature used to indicate the number of active pins used for the opcode (x), address (y), and data (z). At the present time, the only valid Read SFDP instruction modes are: (1-1-1), (2-2-2), and (4-4-4)

Note 3: **Wait States** is required dummy clock cycles after the address bits or optional mode bits.

Note 4: **Mode Bits** is optional control bits that follow the address bits. These bits are driven by the system controller if they are specified. (eg, read performance enhance toggling bits)

Note 5: 4KB=2⁰Ch, 32KB=2⁰Fh, 64KB=2¹0h

Note 6: All unused and undefined area data is blank FFh for SFDP Tables that are defined in Parameter Identification Header. All other areas beyond defined SFDPTable are reserved by Macronix.

10. RESET

Driving the RESET# pin low for a period of tRLRH or longer will reset the device. After reset cycle, the device is at the following states:

- Standby mode
- All the volatile bits such as WEL/WIP/SRAM lock bit will return to the default status as power on.
- 3-byte address mode

If the device is under programming or erasing, driving the RESET# pin low will also terminate the operation and data could be lost. During the resetting cycle, the SO data becomes high impedance and the current will be reduced to minimum.

While Reset operation is during erase suspend, no matter what status the flash device is in, its Reset Recovery time should be referred to the Recovery time of the Erase activity in progress.

Figure 89. RESET Timing

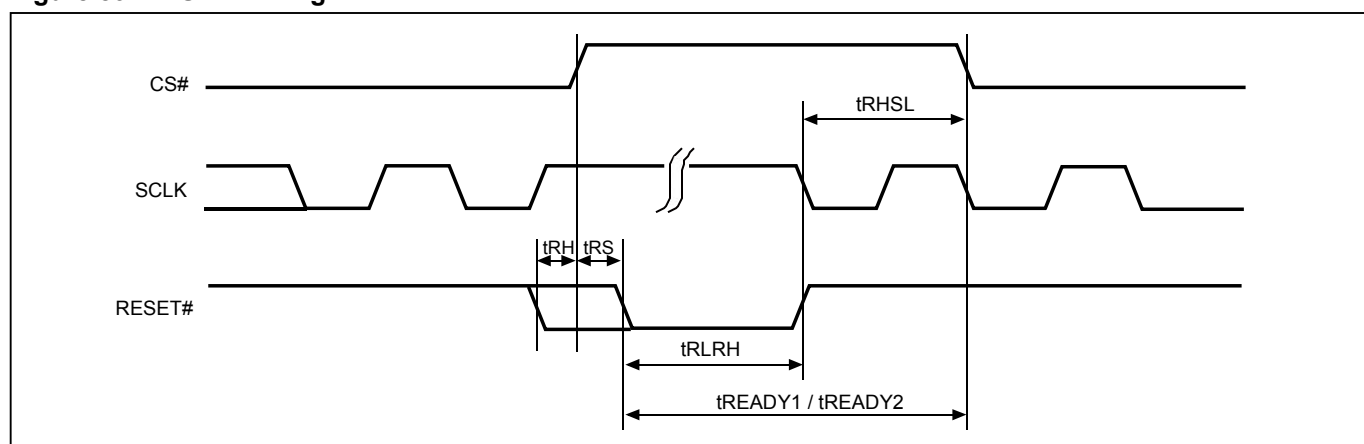

Table 20. Reset Timing-(Power On)

Symbol	Parameter	Min.	Typ.	Max.	Unit
tRHSL	Reset# high before CS# low	10			us
tRS	Reset# setup time	15			ns
tRH	Reset# hold time	15			ns
tRLRH	Reset# low pulse width	10			us
tREADY1	Reset Recovery time	35			us

Table 21. Reset Timing-(Other Operation)

Symbol	Parameter	Min.	Typ.	Max.	Unit
tRHSL	Reset# high before CS# low	10			us
tRS	Reset# setup time	15			ns
tRH	Reset# hold time	15			ns
tRLRH	Reset# low pulse width	10			us
tREADY2	Reset Recovery time (During instruction decoding)	40			us
	Reset Recovery time (for read operation)	35			us
	Reset Recovery time (for program operation)	310			us
	Reset Recovery time (for SE4KB operation)	12			ms
	Reset Recovery time (for BE64K/BE32KB operation)	25			ms
	Reset Recovery time (for Chip Erase operation)	100			ms
	Reset Recovery time (for WRSR operation)	40			ms

Note: For the Reset activity during Erase suspend, its tREADY2 timing should be referred to the Erase activity in progress.



11. POWER-ON STATE

The device is at below states when power-up:

- Standby mode (please note it is not deep power-down mode)
- Write Enable Latch (WEL) bit is reset

The device must not be selected during power-up and power-down stage unless the VCC achieves below correct level:

- VCC minimum at power-up stage and then after a delay of tVSL
- GND at power-down

Please note that a pull-up resistor on CS# may ensure a safe and proper power-up/down level.

An internal power-on reset (POR) circuit may protect the device from data corruption and inadvertent data change during power up state. When VCC is lower than VWI (POR threshold voltage value), the internal logic is reset and the flash device has no response to any command.

For further protection on the device, if the VCC does not reach the VCC minimum level, the correct operation is not guaranteed. The write, erase, and program command should be sent after the below time delay:

- tVSL after VCC reached VCC minimum level

The device can accept read command after VCC reached VCC minimum and a time delay of tVSL.

Please refer to the "[Figure 97. Power-up Timing](#)".

Note:

- To stabilize the VCC level, the VCC rail decoupled by a suitable capacitor close to package pins is recommended. (generally around 0.1uF)
- At power-down stage, the VCC drops below VWI level, all operations are disable and device has no response to any command. The data corruption might occur during the stage while a write, program, erase cycle is in progress.

12. ELECTRICAL SPECIFICATIONS

Table 22. ABSOLUTE MAXIMUM RATINGS

RATING		VALUE
Ambient Operating Temperature	Industrial grade	-40°C to 85°C
Storage Temperature		-65°C to 150°C
Applied Input Voltage		-0.5V to VCC+0.5V
Applied Output Voltage		-0.5V to VCC+0.5V
VCC to Ground Potential		-0.5V to 4.0V

NOTICE:

1. Stresses greater than those listed under ABSOLUTE MAXIMUM RATINGS may cause permanent damage to the device. This is stress rating only and functional operational sections of this specification is not implied. Exposure to absolute maximum rating conditions for extended period may affect reliability.
2. Specifications contained within the following tables are subject to change.
3. During voltage transitions, all pins may overshoot Vss to -2.0V and Vcc to +2.0V for periods up to 20ns, see "[Figure 90. Maximum Negative Overshoot Waveform](#)" and "[Figure 91. Maximum Positive Overshoot Waveform](#)".

Figure 90. Maximum Negative Overshoot Waveform

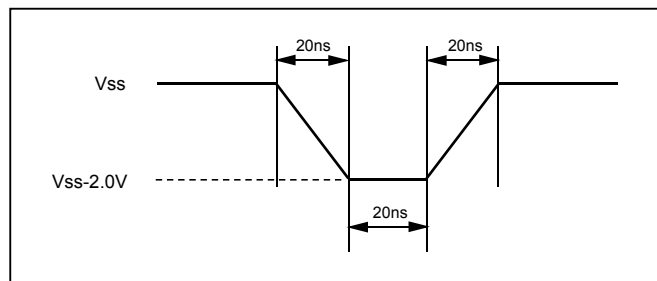

Figure 91. Maximum Positive Overshoot Waveform

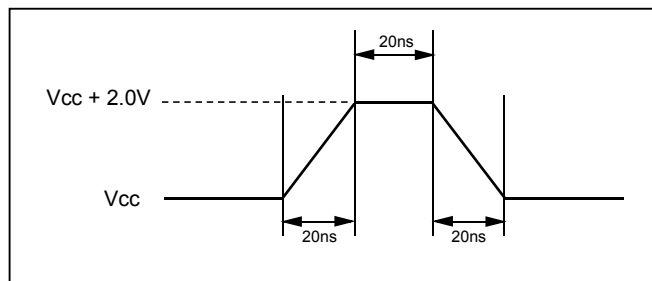

Table 23. CAPACITANCE TA = 25°C, f = 1.0 MHz

Symbol	Parameter	Min.	Typ.	Max.	Unit	Conditions
CIN	Input Capacitance			8	pF	VIN = 0V
COUT	Output Capacitance			10	pF	VOUT = 0V

Figure 92. DATA INPUT TEST WAVEFORMS AND MEASUREMENT LEVEL

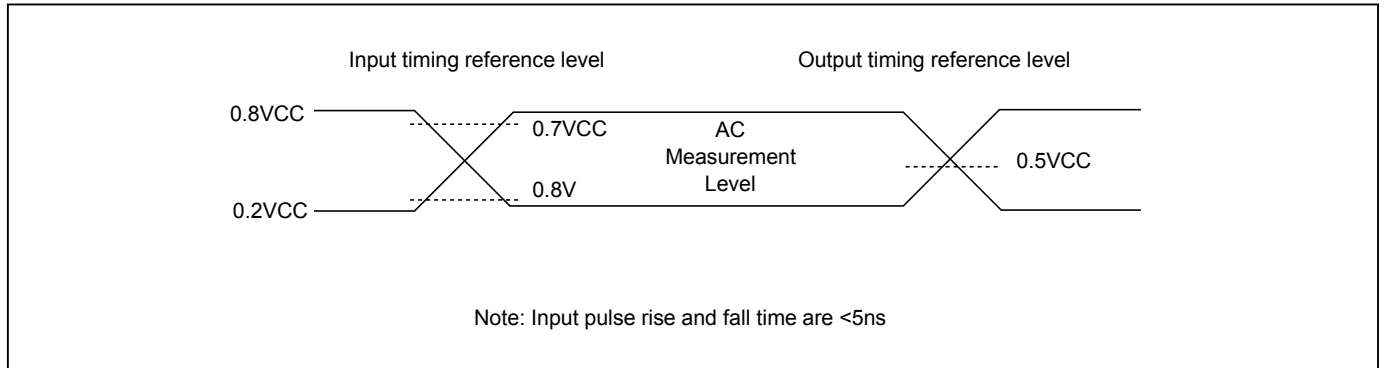

Figure 93. OUTPUT LOADING

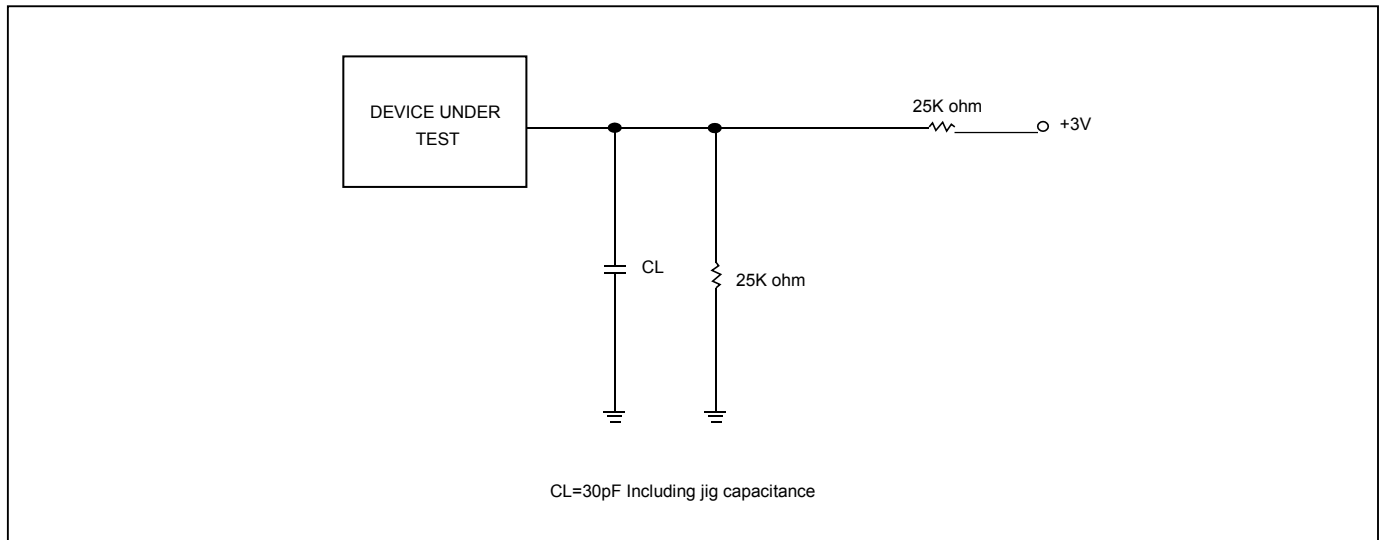

Figure 94. SCLK TIMING DEFINITION

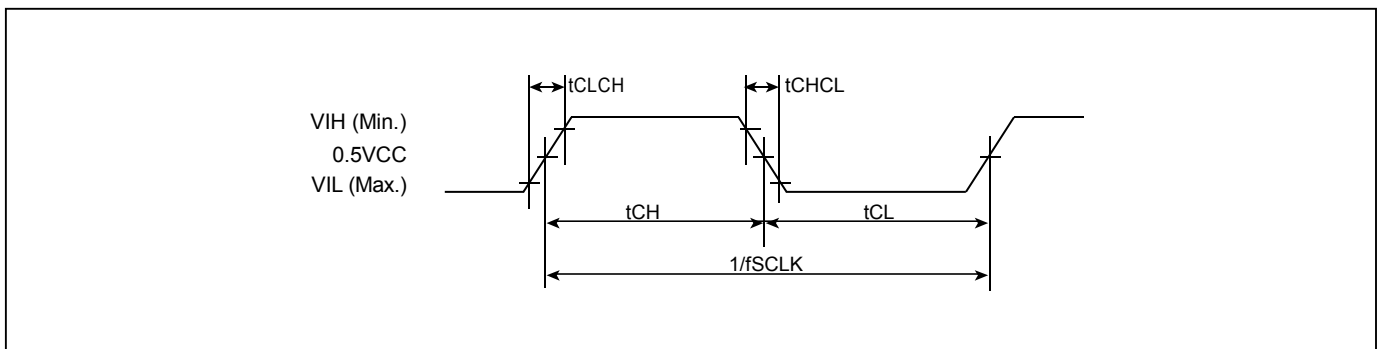

Table 24. DC CHARACTERISTICS (Temperature = -40°C to 85°C, VCC = 2.7V - 3.6V)

Symbol	Parameter	Notes	Min.	Typ.	Max.	Units	Test Conditions
ILI	Input Load Current	1			±2	uA	VCC = VCC Max, VIN = VCC or GND
ILO	Output Leakage Current	1			±2	uA	VCC = VCC Max, VOUT = VCC or GND
ISB1	VCC Standby Current	1		15	100	uA	VIN = VCC or GND, CS# = VCC
ISB2	Deep Power-down Current			3	20	uA	VIN = VCC or GND, CS# = VCC
ICC1	VCC Read	1		16	30	mA	f=133MHz, (4 x I/O read) SCLK=0.1VCC/0.9VCC, SO=Open
				12	25	mA	f=104MHz, (4 x I/O read) SCLK=0.1VCC/0.9VCC, SO=Open
				12	20	mA	f=84MHz, (4 x I/O read) SCLK=0.1VCC/0.9VCC, SO=Open
ICC2	VCC Program Current (PP)	1		12	20	mA	Program in Progress, CS# = VCC
ICC3	VCC Write Status Register (WRSR) Current			10	12	mA	Program status register in progress, CS#=VCC
ICC4	VCC Sector/Block (32K, 64K) Erase Current (SE/BE/BE32K)	1		10	25	mA	Erase in Progress, CS#=VCC
ICC5	VCC Chip Erase Current (CE)	1		14	25	mA	Erase in Progress, CS#=VCC
VIL	Input Low Voltage		-0.5		0.8	V	
VIH	Input High Voltage		0.7VCC		VCC+0.4	V	
VOL	Output Low Voltage				0.2	V	IOL = 100uA
VOH	Output High Voltage		VCC-0.2			V	IOH = -100uA

Notes :

1. Typical values at VCC = 3.3V, T = 25°C. These currents are valid for all product versions (package and speeds).
2. Typical value is calculated by simulation.



Table 25. AC CHARACTERISTICS (Temperature = -40°C to 85°C, VCC = 2.7V - 3.6V)

Symbol	Alt.	Parameter	Min.	Typ.	Max.	Unit
fSCLK	fC	Clock Frequency for all commands (except Read)	D.C.		120	MHz
fRSCLK	fR	Clock Frequency for READ instructions			50	MHz
fTSCLK	fT	Clock Frequency for 2READ/DREAD instructions			80 ⁽⁴⁾	MHz
	fQ	Clock Frequency for 4READ/QREAD instructions			80 ⁽⁴⁾	MHz
tCH ⁽¹⁾	tCLH	Clock High Time	Others (fSCLK)	> 66MHz	45% x (1/fSCLK)	ns
				≤ 66MHz	7	ns
			Normal Read (fRSCLK)	7	ns	
tCL ⁽¹⁾	tCLL	Clock Low Time	Others (fSCLK)	> 66MHz	45% x (1/fSCLK)	ns
				≤ 66MHz	7	ns
			Normal Read (fRSCLK)	7	ns	
tCLCH ⁽⁹⁾		Clock Rise Time (peak to peak)	0.1			V/ns
tCHCL ⁽⁹⁾		Clock Fall Time (peak to peak)	0.1			V/ns
tSLCH	tCSS	CS# Active Setup Time (relative to SCLK)	3			ns
tCHSL		CS# Not Active Hold Time (relative to SCLK)	3			ns
tDVCH/ tDVCL	tDSU	Data In Setup Time	2			ns
tCHDX/ tCLDX	tDH	Data In Hold Time	2			ns
tCHSH		CS# Active Hold Time (relative to SCLK)	3			ns
tSHCH		CS# Not Active Setup Time (relative to SCLK)	3			ns
tSHSL	tCSH	CS# Deselect Time	From Read to next Read	7		ns
			From Write/Erase/Program to Read Status Register	30		ns
tSHQZ ⁽⁹⁾	tDIS	Output Disable Time			8	ns
tCLQV	tV	Clock Low to Output Valid	Loading: 30pF		8	ns
			Loading: 15pF		6	ns
tCLQX	tHO	Output Hold Time	0			ns
tDP ⁽⁹⁾		CS# High to Deep Power-down Mode			10	us
tRES1 ⁽⁹⁾		CS# High to Standby Mode without Electronic Signature Read			30	us
tRES2 ⁽⁹⁾		CS# High to Standby Mode with Electronic Signature Read			30	us
tW		Write Status/Configuration Register Cycle Time			40	ms
tWREAW		Write Extended Address Register		40		ns
tBP		Byte-Program		15	30	us
tPP		Page Program Cycle Time		0.25	0.75	ms
tSE		Sector Erase Cycle Time		30	400	ms
tBE32		Block Erase (32KB) Cycle Time		180	1000	ms
tBE		Block Erase (64KB) Cycle Time		380	2000	ms
tCE		Chip Erase Cycle Time		110	210	s
tESL ⁽⁵⁾		Erase Suspend Latency			25	us
tPSL ⁽⁵⁾		Program Suspend Latency			25	us
tPRS ⁽⁶⁾		Latency between Program Resume and next Suspend	0.3	100		us
tERS ⁽⁷⁾		Latency between Erase Resume and next Suspend	0.3	400		us
tQVD ⁽⁸⁾		Data Output Valid Time Difference among all SIO pins			600	ps

**Notes:**

1. $t_{CH} + t_{CL}$ must be greater than or equal to $1/\text{Frequency}$.
2. Typical values given for $T_A=25^\circ\text{C}$. Not 100% tested.
3. Test condition is shown as "[Figure 92. DATA INPUT TEST WAVEFORMS AND MEASUREMENT LEVEL](#)" and "[Figure 93. OUTPUT LOADING](#)".
4. Please refer to the "[Table 1. Read performance Comparison](#)".
5. Latency time is required to complete Erase/Program Suspend operation until WIP bit is "0".
6. For t_{PRS} , minimum timing must be observed before issuing the next program suspend command. However, a period equal to or longer than the typical timing is required in order for the program operation to make progress.
7. For t_{ERS} , minimum timing must be observed before issuing the next erase suspend command. However, a period equal to or longer than the typical timing is required in order for the erase operation to make progress.
8. Not 100% tested.
9. The value guaranteed by characterization, not 100% tested in production.

13. OPERATING CONDITIONS

At Device Power-Up and Power-Down

AC timing illustrated in [Figure 95](#) and [Figure 96](#) are for the supply voltages and the control signals at device power-up and power-down. If the timing in the figures is ignored, the device will not operate correctly.

During power-up and power-down, CS# needs to follow the voltage applied on VCC to keep the device not to be selected. The CS# can be driven low when VCC reach $V_{CC(min)}$ and wait a period of t_{VSL} .

Figure 95. AC Timing at Device Power-Up

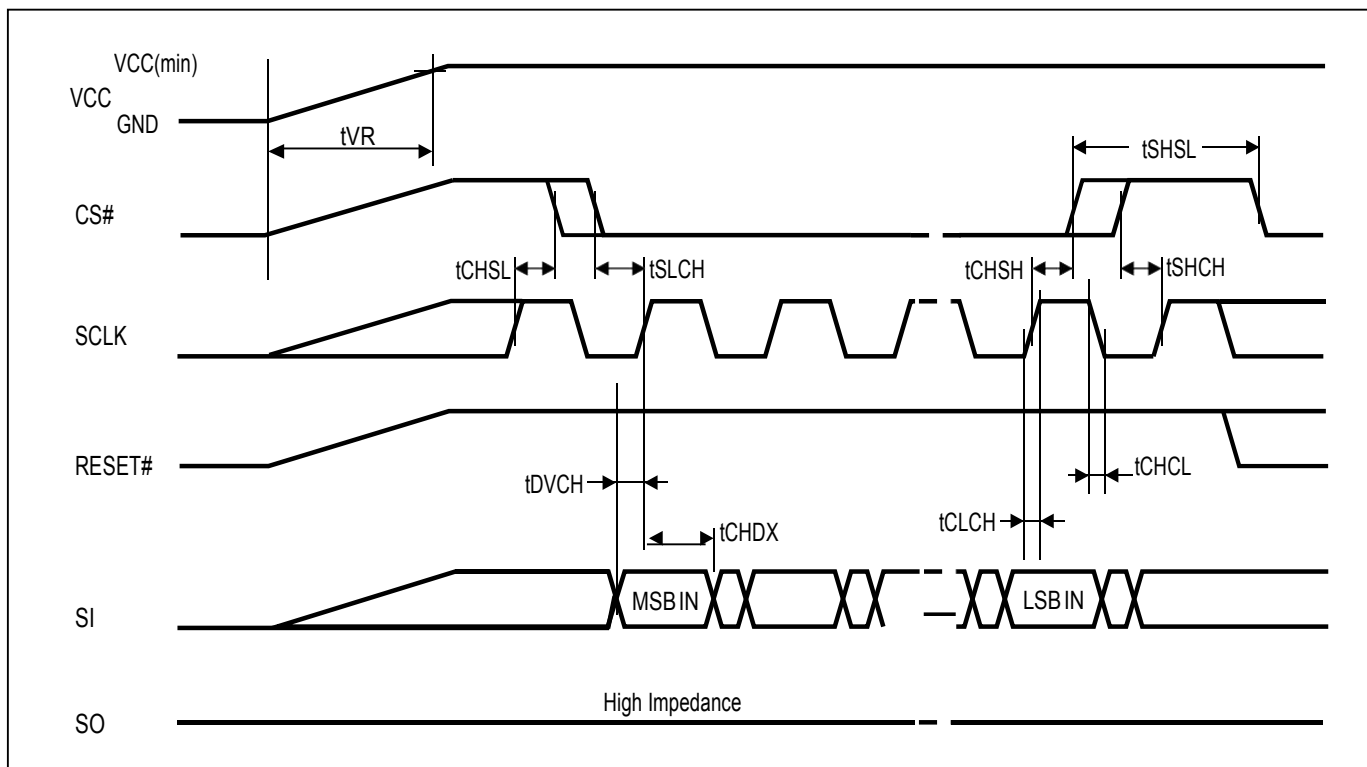

Symbol	Parameter	Notes	Min.	Max.	Unit
tVR	VCC Rise Time	1		500000	us/V

Notes :

1. Sampled, not 100% tested.
2. For AC spec tCHSL, tSLCH, tDVCH, tCHDX, tSHSL, tCHSH, tSHCH, tCHCL, tCLCH in the figure, please refer to [Table 25. AC CHARACTERISTICS](#).

Figure 96. Power-Down Sequence

During power-down, CS# needs to follow the voltage drop on VCC to avoid mis-operation.

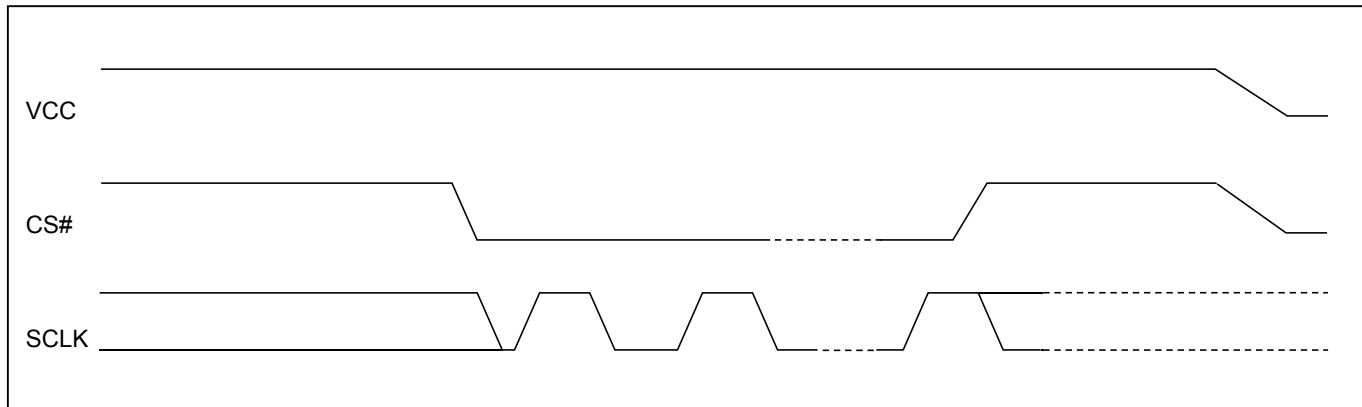

Figure 97. Power-up Timing

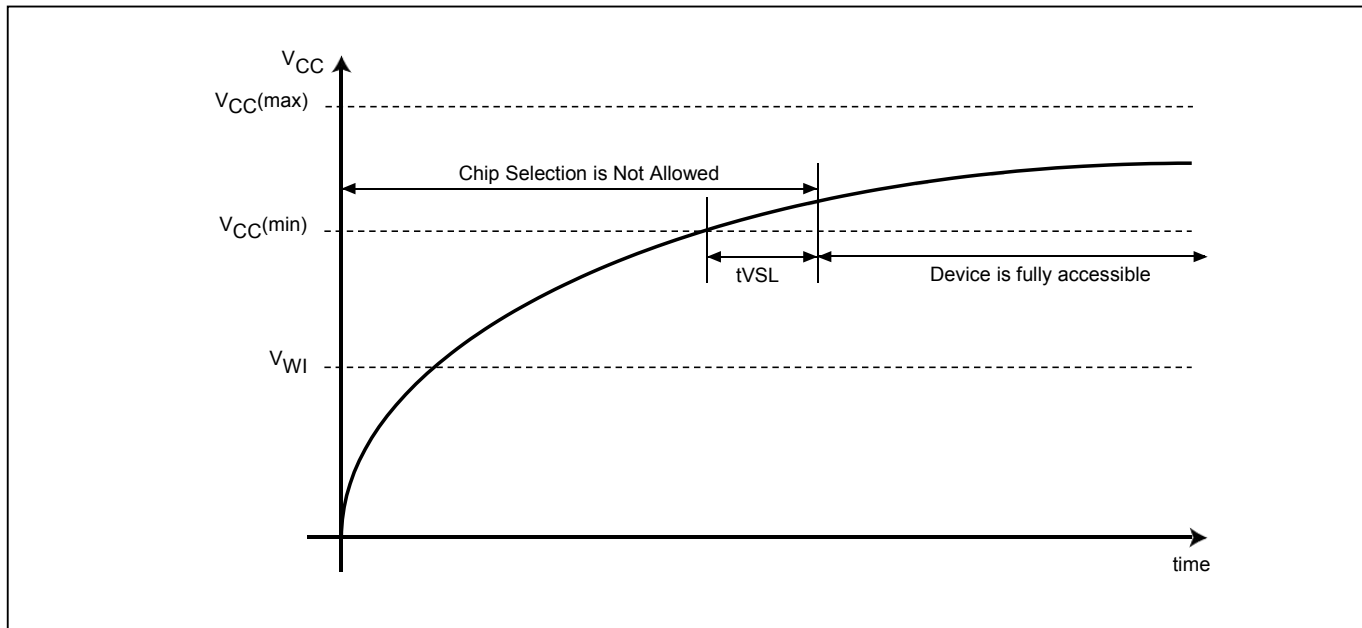

Figure 98. Power Up/Down and Voltage Drop

When powering down the device, VCC must drop below V_{PVD} for at least t_{PVD} to ensure the device will initialize correctly during power up. Please refer to "Figure 98. Power Up/Down and Voltage Drop" and "Table 26. Power-Up/Down Voltage and Timing" below for more details.

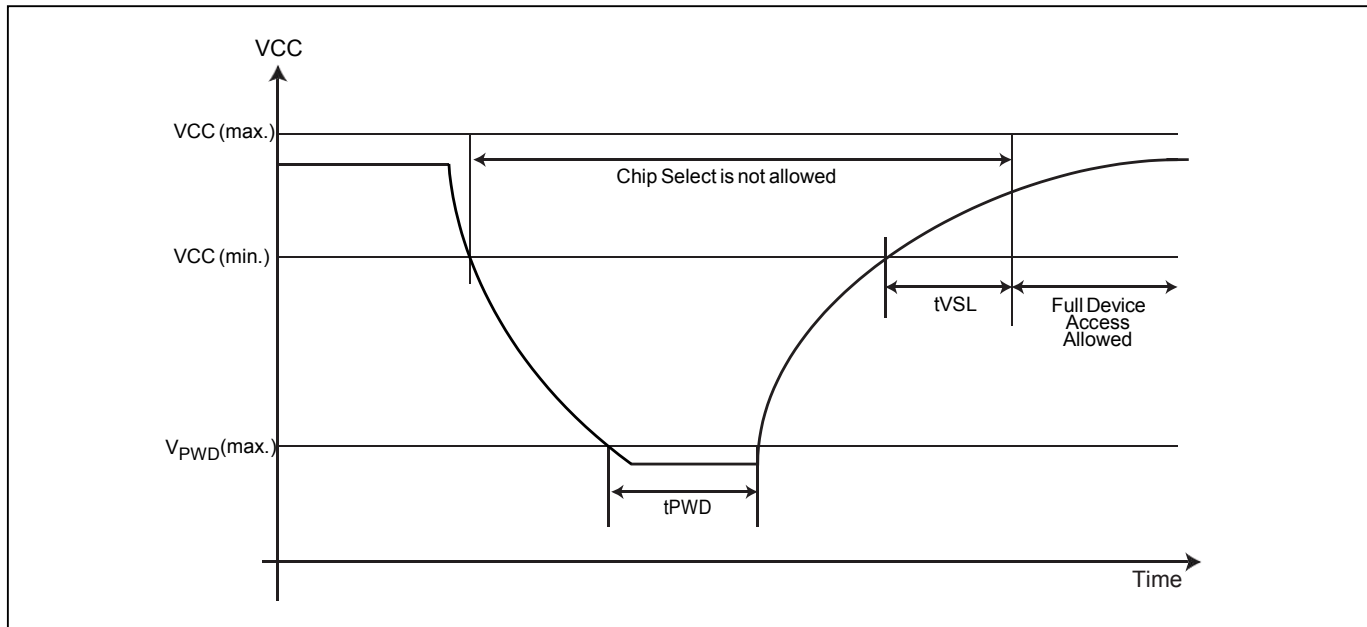

Table 26. Power-Up/Down Voltage and Timing

Symbol	Parameter	Min.	Max.	Unit
tVSL	VCC(min.) to device operation	3000		us
VWI	Write Inhibit Voltage	1.5	2.5	V
V_{PVD}	VCC voltage needed to below V_{PVD} for ensuring initialization will occur		0.9	V
tPVD	The minimum duration for ensuring initialization will occur	300		us
VCC	VCC Power Supply	2.7	3.6	V

Note: These parameters are characterized only.

13-1. INITIAL DELIVERY STATE

The device is delivered with the memory array erased: all bits are set to 1 (each byte contains FFh). The Status Register contains 40h (all Status Register bits are 0 except QE bit: QE=1).

14. ERASE AND PROGRAMMING PERFORMANCE

Parameter	Min.	Typ. ⁽¹⁾	Max. ⁽²⁾	Unit
Write Status Register Cycle Time			40	ms
Sector Erase Cycle Time (4KB)		30	400	ms
Block Erase Cycle Time (32KB)		0.18	1	s
Block Erase Cycle Time (64KB)		0.38	2	s
Chip Erase Cycle Time		110	210	s
Byte Program Time (via page program command)		15	30	us
Page Program Time		0.25	0.75	ms
Erase/Program Cycle		100,000		cycles

Notice:

1. Typical program and erase time assumes the following conditions: 25°C, 3.3V, and all zero pattern.
2. Under worst conditions of 2.7V, highest operation temperature, post program/erase cycling.
3. System-level overhead is the time required to execute the first-bus-cycle sequence for the programming command.

15. ERASE AND PROGRAMMING PERFORMANCE (Factory Mode)

Parameter	Min.	Typ.	Max.	Unit
Sector Erase Cycle Time (4KB)		18		ms
Block Erase Cycle Time (32KB)		100		ms
Block Erase Cycle Time (64KB)		200		ms
Chip Erase Cycle Time		80		s
Page Program Time		0.16		ms
Erase/Program Cycle			50	cycles

Notice:

1. Factory Mode must be operated in 20°C to 45°C and VCC 3.0V-3.6V.
2. In Factory mode, the Erase/Program operation should not exceed 50 cycles, and "ERASE AND PROGRAMMING PERFORMANCE" 100k cycles will not be affected.
3. During factory mode, Suspend command (B0) cannot be executed.



16. DATA RETENTION

Parameter	Condition	Min.	Max.	Unit
Data retention	55°C	20		years

17. LATCH-UP CHARACTERISTICS

	Min.	Max.
Input Voltage with respect to GND on all power pins		1.5 VCCmax
Input Current on all non-power pins	-100mA	+100mA
Test conditions: VCC = VCCmax, one pin at a time (compliant to JEDEC JDESD78 standard).		



18. ORDERING INFORMATION

Please contact Macronix regional sales for the latest product selection and available form factors.

PART NO.	TEMPERATURE	PACKAGE	Remark
MX25L25673GMI-10G	-40°C to 85°C	16-SOP (300mil)	
MX25L25673GM2I-10G	-40°C to 85°C	8-SOP(200mil)	
MX25L25673GMI-08G	-40°C to 85°C	16-SOP (300mil)	Support Factory Mode
MX25L25673GM2I-08G	-40°C to 85°C	8-SOP(200mil)	Support Factory Mode
MX25L25673GZNI-08G	-40°C to 85°C	8-WSON (6x5mm)	Support Factory Mode
MX25L25673GZ4I-08G	-40°C to 85°C	8-WSON (8x6mm 3.4 x 4.3 EP)	Support Factory Mode
MX25L25673GZNI-10G	-40°C to 85°C	8-WSON (6x5mm)	

19. PART NAME DESCRIPTION

MX 25 L 25673G M2 I - 10 G

OPTION:

G: RoHS Compliant and Halogen-free

Factory Mode:

10: Notsupport

08: Support

TEMPERATURE RANGE:

I: Industrial (-40°C to 85°C)

PACKAGE:

M: 16-SOP (300mil)

M2: 8-SOP(200mil)

ZN: 8-WSON (6x5mm)

Z4: 8-WSON (8x6mm, 3.4 x 4.3 EP)

DENSITY & MODE:

25673G: 256Mb, default Quad I/O enable, and can not be change

TYPE:

L: 3V

DEVICE:

25: Serial NOR Flash

20. PACKAGE INFORMATION

20-1. 16-pin SOP (300mil)

Doc. Title: Package Outline for SOP 16L (300MIL)

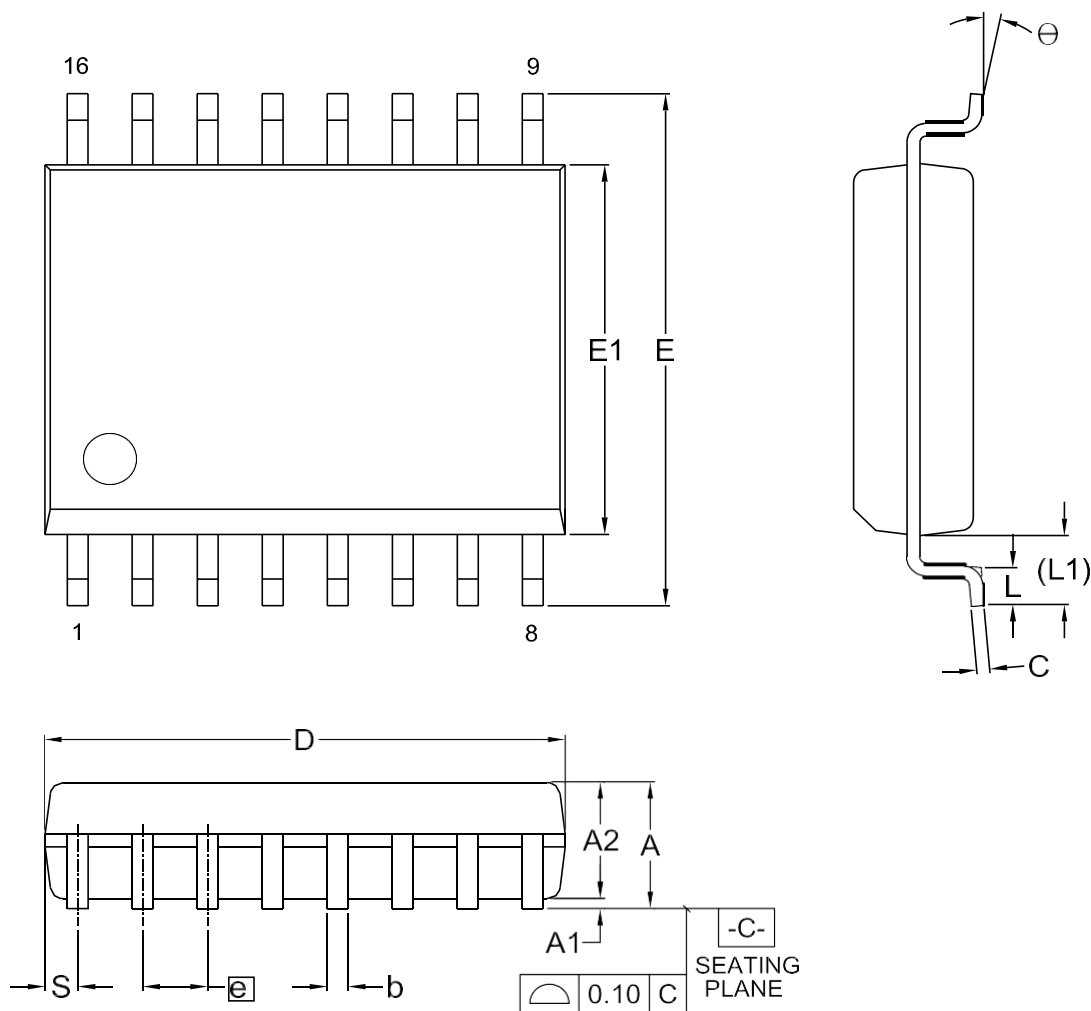

Dimensions (inch dimensions are derived from the original mm dimensions)

SYMBOL		A	A1	A2	b	C	D	E	E1	e	L	L1	S	θ
UNIT	Mir.	---	0.10	2.25	0.31	0.20	10.10	10.10	7.42	---	0.40	1.31	0.51	0°
	Nor.	---	0.20	2.35	0.41	0.25	10.30	10.30	7.52	1.27	0.84	1.44	0.64	5°
	Max	2.65	0.30	2.45	0.51	0.30	10.50	10.50	7.60	---	1.27	1.57	0.77	8°
Inch	Mir.	---	0.004	0.089	0.012	0.008	0.397	0.397	0.292	---	0.016	0.052	0.020	0°
	Nor.	---	0.008	0.093	0.016	0.010	0.405	0.405	0.296	0.050	0.033	0.057	0.025	5°
	Max	0.104	0.012	0.096	0.020	0.012	0.413	0.413	0.299	---	0.050	0.062	0.030	8°

20-2. 8-pins SOP (200mil)

Doc. Title: Package Outline for SOP 8L 200MIL (official name - 209MIL)

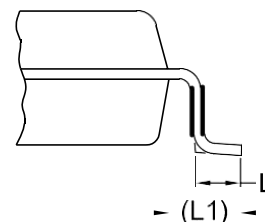
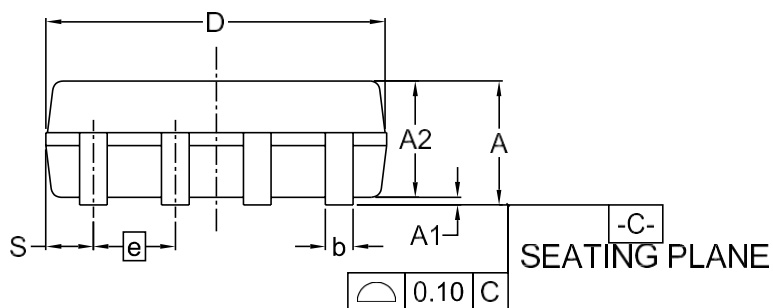
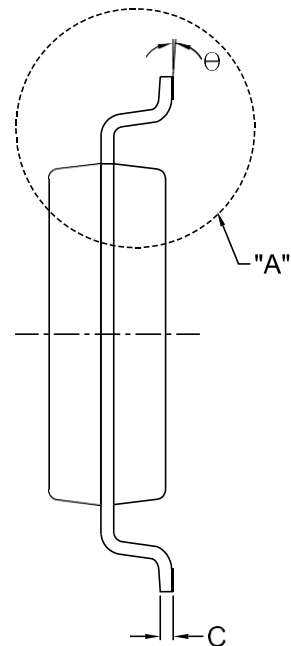
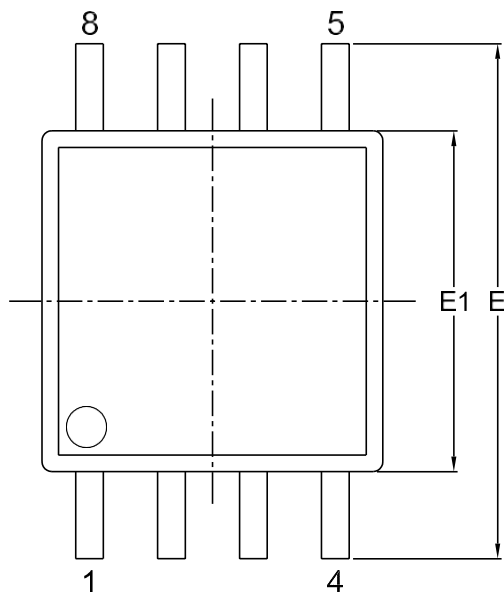

DETAIL "A"

Dimensions (inch dimensions are derived from the original mm dimensions)

SYMBOL		A	A1	A2	b	C	D	E	E1	e	L	L1	S	θ
UNIT														
mm	Min.	1.75	0.05	1.70	0.36	0.19	5.13	7.70	5.18	--	0.50	1.21	0.62	0°
	Nom.	1.95	0.15	1.80	0.41	0.20	5.23	7.90	5.28	1.27	0.65	1.31	0.74	5°
	Max.	2.16	0.20	1.91	0.51	0.25	5.33	8.10	5.38	--	0.80	1.41	0.88	8°
Inch	Min.	0.069	0.002	0.067	0.014	0.007	0.202	0.303	0.204	--	0.020	0.048	0.024	0°
	Nom.	0.077	0.006	0.071	0.016	0.008	0.206	0.311	0.208	0.050	0.026	0.052	0.029	5°
	Max.	0.085	0.008	0.075	0.020	0.010	0.210	0.319	0.212	--	0.031	0.056	0.035	8°

20-3. 8-land WSON (6x5mm)

Doc. Title: Package Outline for WSON 8L (6x5x0.8MM, LEAD PITCH 1.27MM)

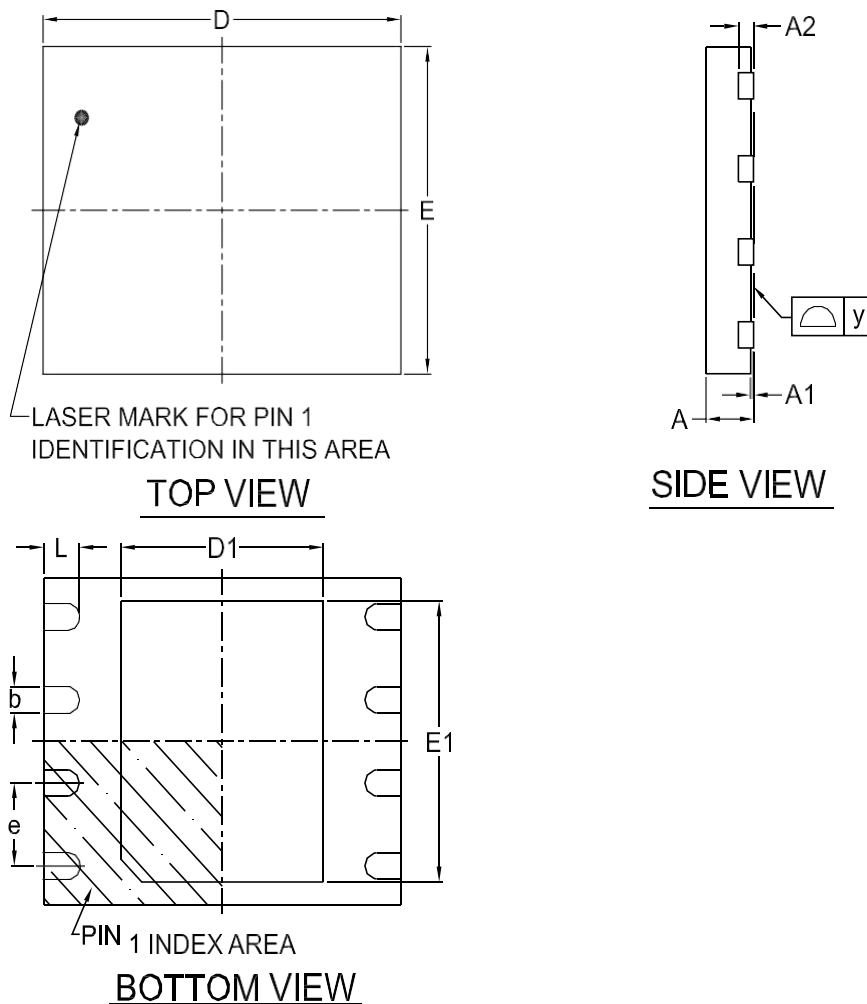

Note:

This package has an exposed metal pad underneath the package. It is recommended to leave the metal pad floating or to connect it to the same ground as the GND pin of the package. Do not connect the metal pad to any other voltage or signal line on the PCB. Avoid placing vias or traces underneath the metal pad. Connection of this metal pad to any other voltage or signal line can result in shorts and/or electrical malfunction of the device.

Dimensions (inch dimensions are derived from the original mm dimensions)

SYMBOL	A	A1	A2	b	D	D1	E	E1	L	e	y	
UNIT	Min.	0.70	--	--	0.35	5.90	3.35	4.90	3.95	0.55	--	0.00
	Norm.	--	--	0.20	0.40	6.00	3.40	5.00	4.00	0.60	1.27	--
	Max.	0.80	0.05	--	0.48	6.10	3.45	5.10	4.05	0.65	--	0.05
Inch	Min.	0.028	--	--	0.014	0.232	0.132	0.193	0.156	0.022	--	0.00
	Norm.	--	--	0.008	0.016	0.236	0.134	0.197	0.157	0.024	0.05	--
	Max.	0.032	0.002	--	0.019	0.240	0.136	0.201	0.159	0.026	--	0.002

20-4. 8-land WSON (8x6mm 3.4 x 4.3EP)

Doc. Title: Package Outline for WSON 8L (8x6x0.8MM, LEAD PITCH 1.27MM, E.P. 3.4x4.3MM)

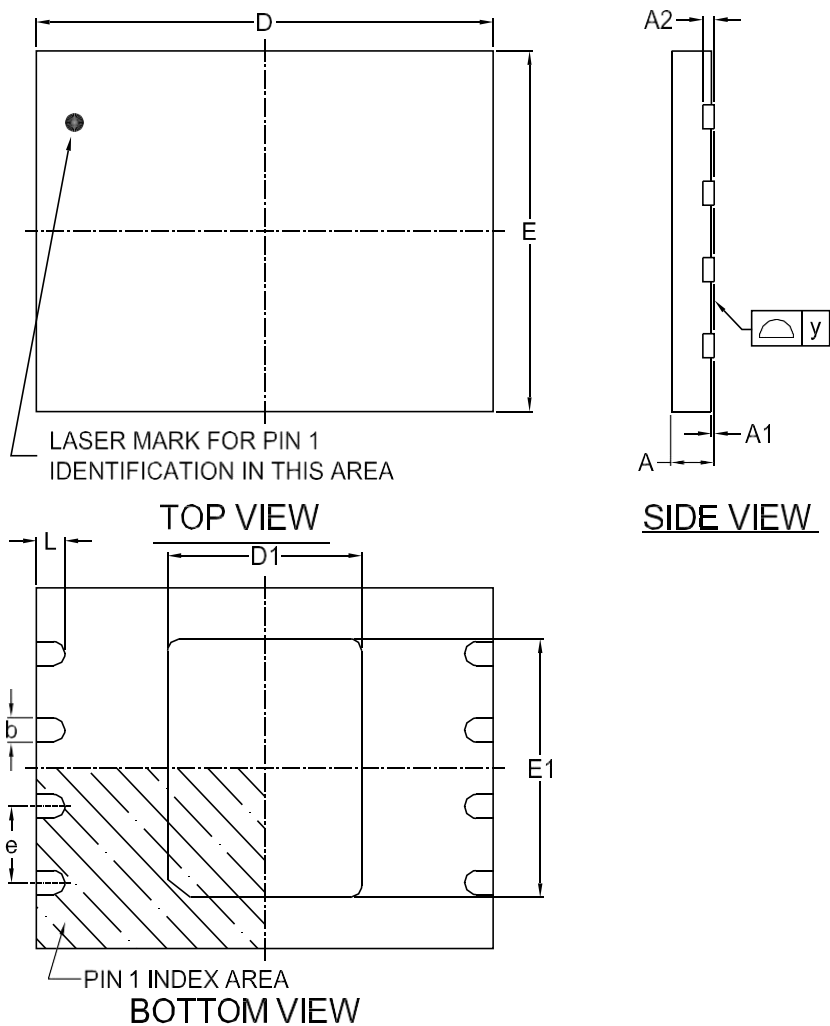

Note:

This package has an exposed metal pad underneath the package. It is recommended to leave the metal pad floating or to connect it to the same ground as the GND pin of the package. Do not connect the metal pad to any other voltage or signal line on the PCB. Avoid placing vias or traces underneath the metal pad. Connection of this metal pad to any other voltage or signal line can result in shorts and/or electrical malfunction of the device.

Dimensions (inch dimensions are derived from the original mm dimensions)

SYMBOL	A	A1	A2	b	D	D1	E	E1	L	e	y
UNIT	0.70	—	—	0.35	7.90	3.35	5.90	4.25	0.45	—	0.00
mm	Min.	—	—	0.20	8.00	3.40	6.00	4.30	0.50	1.27	—
	Norm.	0.80	0.05	—	0.48	3.45	6.10	4.35	0.55	—	0.05
	Max.	0.028	—	—	0.014	0.311	0.132	0.232	0.167	0.018	—
Inch	Min.	—	—	0.008	0.315	0.134	0.236	0.169	0.020	0.05	—
	Norm.	0.032	0.002	—	0.019	0.136	0.240	0.171	0.022	—	0.002
	Max.	—	—	—	—	—	—	—	—	—	—



21. REVISION HISTORY

Revision No.	Description	Page	Date
1.0	1. Removed "Advanced Information" to align with the product status 2. Added MX25L25673GMI-08G & MX25L25673GM2I-08G Part No. 3. Added Factory Mode information 4. Added a statement for product ordering information 5. Modified ICC1/ICC2/ICC3 value	All P109,110 P18,23,24,107 P109 P101	FEB/18/2016
1.1	1. Updated tCH/tCL/tCE/tPP values 2. Revised the descriptions of erase/program cycle in Factory Mode 3. Updated tVR descriptions 4. Added 8-WSON (6x5mm) package 5. Content modification	P102,107 P107 P104,106 P4,6,109,110,113 P50-53,59	SEP/02/2016
1.2	1. Removed the QPI support for WPSEL/GBLK/GBULK commands as a typo correction. 2. Added " Figure 94. SCLK TIMING DEFINITION " 3. Updated the note for the internal pull up status of RESET# 4. Content correction	P18,19,78 P100 P6 P53	MAY/09/2017
1.3	1. Added Key Features on the cover page. 2. Added Resistance values in " Table 9. Output Driver Strength Table ". 3. Modified SRWD bit (Status Register Bit 7) to Reserved and modified INITIAL DELIVERY STATE descriptions 4. Updated Min. tVSL to 3000us. 5. Four I/O read mode description correction modification. 6. Secured OTP indicator bit description modification 7. EN4B instruction description correction 8. Power Up/Down and Voltage Drop description modification 9. Added a new package: 8-land WSON (8x6mm 3.4 x 4.3EP) 10. Added two part numbers: MXL25L25673GZ4I-08G & MX25L25673GZNI-10G 11. Modified " 19. PART NAME DESCRIPTION ". 12. Format modification.	P1 P35 P31-33, 37-38 P106 P106 P5, 46-47, 58 P10, 70 P39 P106 P4, 6, 110, 114 P109 P110 P111-114	JUN/27/2017
1.4	1. Updated " 20-4. 8-land WSON (8x6mm 3.4 x 4.3EP) " in Min./Max. D1, E1 and L values. 2. Updated " 20-3. 8-land WSON (6x5mm) " in Min./Max. D1, E1 and L values. 3. Corrected RDP (Release from Deep Power-down) descriptions 4. Revised " 9-22. Burst Read " descriptions. 5. Updated " 9-28. Page Program (PP) " descriptions. 6. Updated " 9-30. Deep Power-down (DP) " descriptions. 7. Added WRSCUR and RDSCUR command figures. 8. Revised the E_FAIL and P_FAIL bits descriptions. 9. Modified the notes descriptions of AC Table. 10. Content modification.	P116 P115 P25 P57 P65 P68 P69-70 P72 P104-105 P15, 35, 104	AUG/24/2017



Revision No.	Description	Page	Date
1.5	1. Added "Macronix Proprietary" footnote.	All	DEC/20/2019
	2. 4READ Action description modification.	P17	
	3. Revised the descriptions of Performance Enhance Mode and wrap around feature.	P48, 59	
	4. Figure 91 title modification.	P103	
	5. Revised the Max. Erase/Program note descriptions of ERASE AND PROGRAMMING PERFORMANCE Table.	P110	
	6. Modified Serial Input Timing (STR mode/DTR mode).	P13	
	7. Added tDVCL and tCLDX values.	P13, 105	
	8. Content correction.	P1, 4, 9, 37,	
	9. Revised Max. Chip erase time.	P105, 110	
	10. Added RESET# in <i>"Figure 95. AC Timing at Device Power-Up"</i> .	P107	
	11. Modified the descriptions of <i>"17. LATCH-UP CHARACTERISTICS"</i>	P111	



MX25L25673G

Except for customized products which has been expressly identified in the applicable agreement, Macronix's products are designed, developed, and/or manufactured for ordinary business, industrial, personal, and/or household applications only, and not for use in any applications which may, directly or indirectly, cause death, personal injury, or severe property damages. In the event Macronix products are used in contradicted to their target usage above, the buyer shall take any and all actions to ensure said Macronix's product qualified for its actual use in accordance with the applicable laws and regulations; and Macronix as well as it's suppliers and/or distributors shall be released from any and all liability arisen therefrom.

Copyright© Macronix International Co., Ltd. 2015-2019. All rights reserved, including the trademarks and tradename thereof, such as Macronix, MXIC, MXIC Logo, MX Logo, Integrated Solutions Provider, Nbit, Macronix NBit, HybridNVM, HybridFlash, HybridXFlash, XtraROM, KH Logo, BE-SONOS, KSMC, Kingtech, MXSMIO, Macronix vEE, RichBook, Rich TV, OctaBus, FitCAM, ArmorFlash. The names and brands of third party referred thereto (if any) are for identification purposes only.

For the contact and order information, please visit Macronix's Web site at: <http://www.macronix.com>

MACRONIX INTERNATIONAL CO., LTD. reserves the right to change product and specifications without notice.