



*3V, 1G-bit NAND Flash Memory*  
**MX30LF1G18AC**

# Contents

<b>1. FEATURES.....</b>	<b>5</b>
<b>2. GENERAL DESCRIPTIONS.....</b>	<b>6</b>
Figure 1. Logic Diagram.....	6
<b>2-1. ORDERING INFORMATION.....</b>	<b>7</b>
<b>3. PIN CONFIGURATIONS.....</b>	<b>8</b>
<b>3-1. PIN DESCRIPTIONS.....</b>	<b>10</b>
<b>4. BLOCK DIAGRAM.....</b>	<b>12</b>
<b>5. SCHEMATIC CELL LAYOUT AND ADDRESS ASSIGNMENT.....</b>	<b>13</b>
Table 1. Address Allocation.....	13
<b>6. DEVICE OPERATIONS.....</b>	<b>14</b>
<b>6-1. Address Input/Command Input/Data Input.....</b>	<b>14</b>
Figure 2. AC Waveforms for Command / Address / Data Latch Timing.....	14
Figure 3. AC Waveforms for Address Input Cycle.....	14
Figure 4. AC Waveforms for Command Input Cycle.....	15
Figure 5. AC Waveforms for Data Input Cycle.....	15
<b>6-2. Page Read.....</b>	<b>16</b>
Figure 6. AC Waveforms for Read Cycle.....	16
Figure 7. AC Waveforms for Read Operation (Intercepted by CE#).....	17
Figure 8. AC Waveforms for Read Operation (with CE# Don't Care).....	18
Figure 9-1. AC Waveforms for Sequential Data Out Cycle (After Read).....	18
Figure 9-2. AC Waveforms for Sequential Data Out Cycle (After Read) -EDO Mode.....	19
Figure 10. AC Waveforms for Random Data Output.....	20
<b>6-3. Cache Read Sequential.....</b>	<b>21</b>
Figure 11-1. AC Waveforms for Cache Read Sequential.....	22
<b>6-4. Cache Read Random.....</b>	<b>23</b>
Figure 11-2. AC Waveforms for Cache Read Random.....	24
<b>6-5. Page Program.....</b>	<b>25</b>
Figure 12. AC Waveforms for Program Operation after Command 80H.....	25
Figure 13. AC Waveforms for Random Data In (For Page Program).....	26
Figure 14. AC Waveforms for Program Operation with CE# Don't Care.....	27
<b>6-6. Cache Program.....</b>	<b>28</b>
Figure 15-1. AC Waveforms for Cache Program.....	29
Figure 15-2. AC Waveforms for Sequence of Cache Program.....	30



**6-7. Block Erase..... 31**  
Figure 16. AC Waveforms for Erase Operation..... 31

**6-8. ID Read..... 32**  
Table 2. ID Codes Read Out by ID Read Command 90H..... 32  
Table 3. The Definition of Byte2-Byte4 of ID Table..... 33  
Figure 17-1. AC Waveforms for ID Read Operation..... 34  
Figure 17-2. AC Waveforms for ID Read (ONFI Identifier) Operation..... 34

**6-9. Status Read..... 35**  
Table 4. Status Output..... 35  
Figure 18. Bit Assignment (HEX Data)..... 36  
Figure 19. AC Waveforms for Status Read Operation..... 36

**6-10. Block Protection Status Read..... 37**  
Table 5. Block-Protection Status Output..... 37  
Table 6. Address Cycle Definition of Block..... 37  
Figure 20. AC Waveforms for Block Protection Status Read..... 38

**6-11. Reset..... 39**  
Figure 21. AC waveforms for Reset Operation..... 39

**6-12. Parameter Page Read (ONFI)..... 40**  
Figure 22. AC waveforms for Parameter Page Read (ONFI) Operation..... 40  
Figure 23. AC Waveforms for Parameter Page Read (ONFI) Random Operation(For 05h-E0h)..... 41  
Table 7. Parameter Page (ONFI)..... 42

**6-13. Unique ID Read (ONFI)..... 44**  
Figure 24. AC waveforms for Unique ID Read Operation..... 44  
Figure 25. AC waveforms for Unique ID Read Operation (For 05h-E0h)..... 45

**6-14. Feature Set Operation (ONFI)..... 46**  
Table 8-1. Definition of Feature Address..... 46  
Table 8-2. Sub-Feature Parameter Table of Feature Address - 90h (Array Operation Mode)..... 46  
Table 8-3. Sub-Feature Parameter Table of Feature Address-A0h (Block Protection Operation) (note 1)..... 46

**6-14-1. Set Feature (ONFI)..... 47**  
Figure 26. AC Waveforms for Set Feature (ONFI) Operation..... 47

**6-14-2. Get Feature (ONFI)..... 48**  
Figure 27. AC Waveforms for Get Feature (ONFI) Operation..... 48

**6-14-3. Secure OTP (One-Time-Programmable) Feature..... 49**  
Figure 28. AC Waveforms for OTP Data Read..... 49  
Figure 29. AC Waveforms for OTP Data Read with Random Data Output..... 50  
Figure 30. AC Waveforms for OTP Data Program..... 51  
Figure 31. AC Waveforms for OTP Data Program with Random Data Input..... 52  
Figure 32. AC Waveforms for OTP Protection Operation..... 53

**6-14-4. Block Protection..... 54**  
Table 9. Definition of Protection Bits..... 54  
Figure 33. PT Pin and Block Protection Mode Operation..... 55



宇翔达 .....56

**7-1. ABSOLUTE MAXIMUM RATINGS.....56**

Figure 34. Maximum Negative Overshoot Waveform..... 56

Figure 35. Maximum Positive Overshoot Waveform..... 56

Table 10. Operating Range.....57

Table 11. DC Characteristics..... 57

Table 12. Capacitance.....58

Table 13. AC Testing Conditions..... 58

Table 14. Program and Erase Characteristics..... 58

Table 15. AC Characteristics..... 59

**8. OPERATION MODES: LOGIC AND COMMAND TABLES.....60**

Table 16. Logic Table.....60

Table 17. HEX Command Table.....61

**8-1. R/B#: Termination for The Ready/Busy# Pin (R/B#)..... 62**

Figure 36. R/B# Pin Timing Information..... 63

**8-2. Power On/Off Sequence..... 64**

Figure 37. Power On/Off Sequence.....64

**8-2-1.WP# Signal..... 65**

Figure 38-1. Enable Programming of WP# Signal.....65

Figure 38-2. Disable Programming of WP# Signal.....65

Figure 38-3. Enable Erasing of WP# Signal.....65

Figure 38-4. Disable Erasing of WP# Signal.....65

**9. SOFTWARE ALGORITHM..... 66**

**9-1. Invalid Blocks (Bad Blocks)..... 66**

Figure 39. Bad Blocks.....66

Table 18. Valid Blocks.....66

**9-2. Bad Block Test Flow..... 67**

Figure 40. Bad Block Test Flow.....67

**9-3. Failure Phenomena for Read/Program/Erase Operations..... 67**

Table 19. Failure Modes.....67

**9-4. Program..... 68**

Figure 41. Failure Modes.....68

Figure 42. Program Flow Chart.....68

**9-5. Erase..... 68**

Figure 43. Erase Flow Chart.....69

Figure 44. Read Flow Chart.....69

**10. PACKAGE INFORMATION..... 70**

**11. REVISION HISTORY..... 72**

## 1. FEATURES

- 1G-bit SLC NAND Flash
    - Bus: x8
    - Page size: (2048+64) byte,
    - Block size: (128K+4K) byte,
  - **ONFI 1.0 compliant**
  - **Multiplexed Command/Address/Data**
  - **User Redundancy**
    - 64-byte attached to each page
  - **Fast Read Access**
    - Latency of array to register: 25us
    - Sequential read: 20ns
  - **Cache Read Support**
  - **Page Program Operation**
    - Page program time: 300us( typ.)
  - **Cache Program Support**
  - **Block Erase Operation**
    - Block erase time: 1ms (typ.)
  - **Single Voltage Operation:**
    - VCC: 2.7 - 3.6V
  - **Low Power Dissipation**
    - Max. 30mA
    - Active current (Read/Program/Erase)
  - **Sleep Mode**
    - 50uA (Max) standby current
  - **Hardware Data Protection: WP# pin**
  - **Block Protection**
    - PT (Protection) pin: active high at power-on, which protects the entire chip. The pin has an internal weak pull down.
    - Temporary protection/un-protection function (enabling by PT pin)
    - Solid protection (enabling by PT pin)
  - **Device Status Indicators**
    - Ready/Busy (R/B#) pin
    - Status Register
  - **Chip Enable Don't Care**
    - Simplify System Interface
  - **Unique ID Read support (ONFI)**
  - **Secure OTP support**
  - **High Reliability**
    - Endurance: typical 100K cycles (with 4-bit ECC per (512+16) Byte)
    - Data Retention: 10 years
  - **Wide Temperature Operating Range**
    - 40°C to +85°C
  - **Package:**
    - 1) 48-TSOP(I) (12mm x20mm)
    - 2) 63-ball 9mmx11mm VFBGA
- All packaged devices are RoHS Compliant and Halogen-free.

## 2. GENERAL DESCRIPTIONS

The MX30LF1G18AC is a 1Gb SLC NAND Flash memory device. Its standard NAND Flash features and reliable quality of typical P/E cycles 100K (with ECC), which makes it most suitable for embedded system code and data storage.

The product family requires 4-bit ECC per (512+16)B.

The MX30LF1G18AC is typically accessed in pages of 2,112 bytes for read and program operations.

The MX30LF1G18AC array is organized as thousands of blocks, which is composed by 64 pages of (2,048+64) byte in two NAND strings structure with 32 serial connected cells in each string. Each page has an additional 64 bytes for ECC and other purposes. The device has an on-chip buffer of 2,112 bytes for data load and access.

The Cache Read Operation of the MX30LF1G18AC enables first-byte read-access latency of 25us and sequential read of 20ns and the latency time of next sequential page will be shorten from tR to tRCBSY.

The MX30LF1G18AC power consumption is 30mA during all modes of operations (Read/Program/Erase), and 50uA in standby mode.

**Figure 1. Logic Diagram**

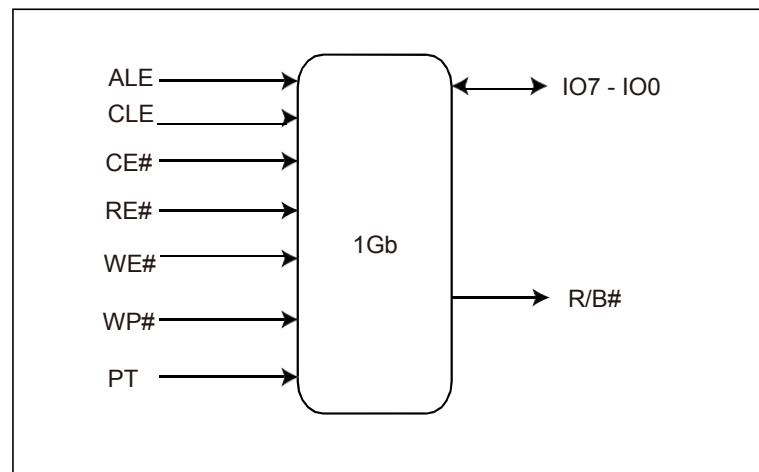

**2-1. ORDERING INFORMATION**

**Part Name Description**

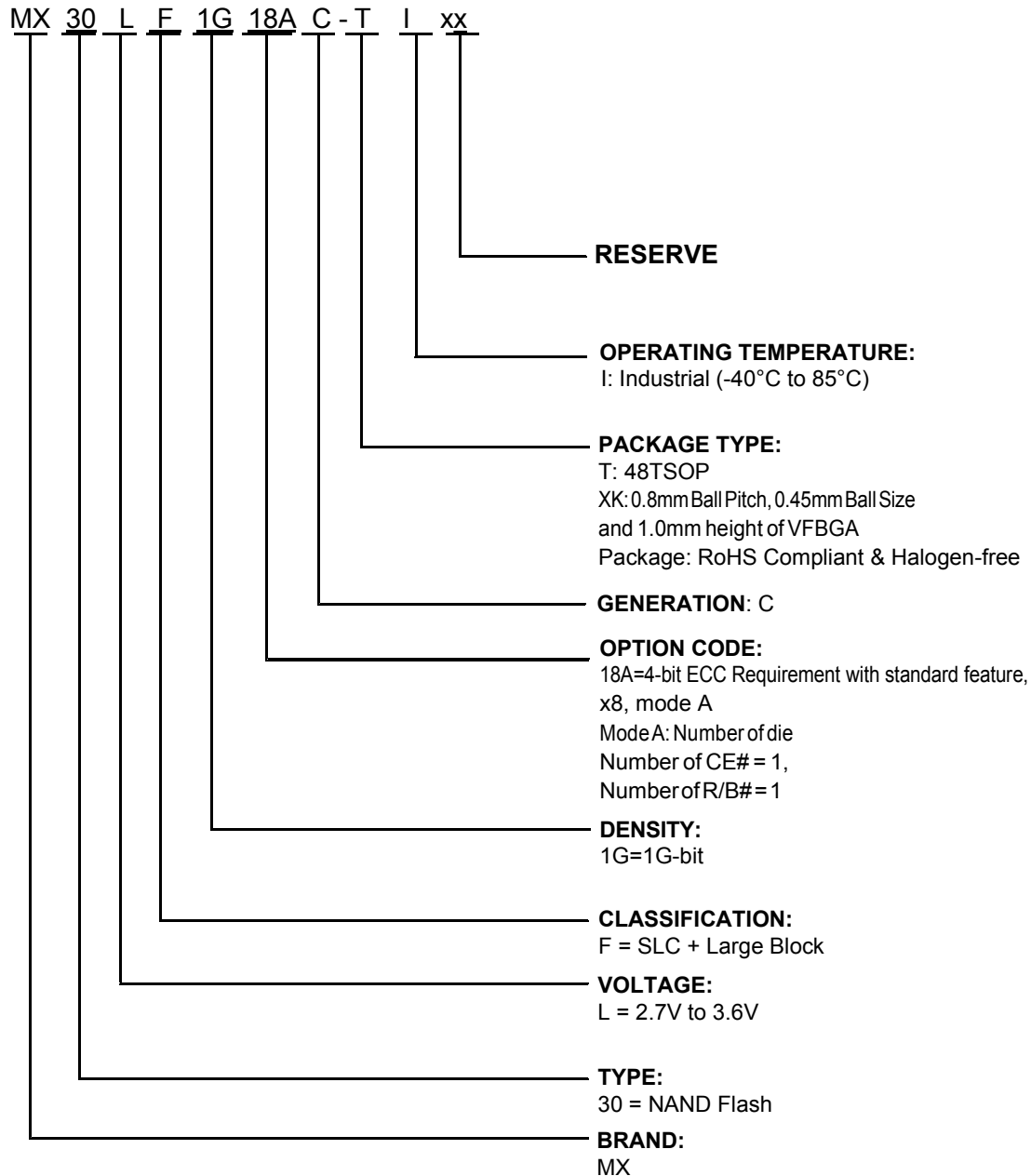

Part Number	Density	Organization	VCC Range	Package	Temperature Grade
MX30LF1G18AC-TI	1Gb	x8	3V	48-TSOP	Industrial
MX30LF1G18AC-XKI	1Gb	x8	3V	63-VFBGA	Industrial

### 3. PIN CONFIGURATIONS

#### 48-TSOP

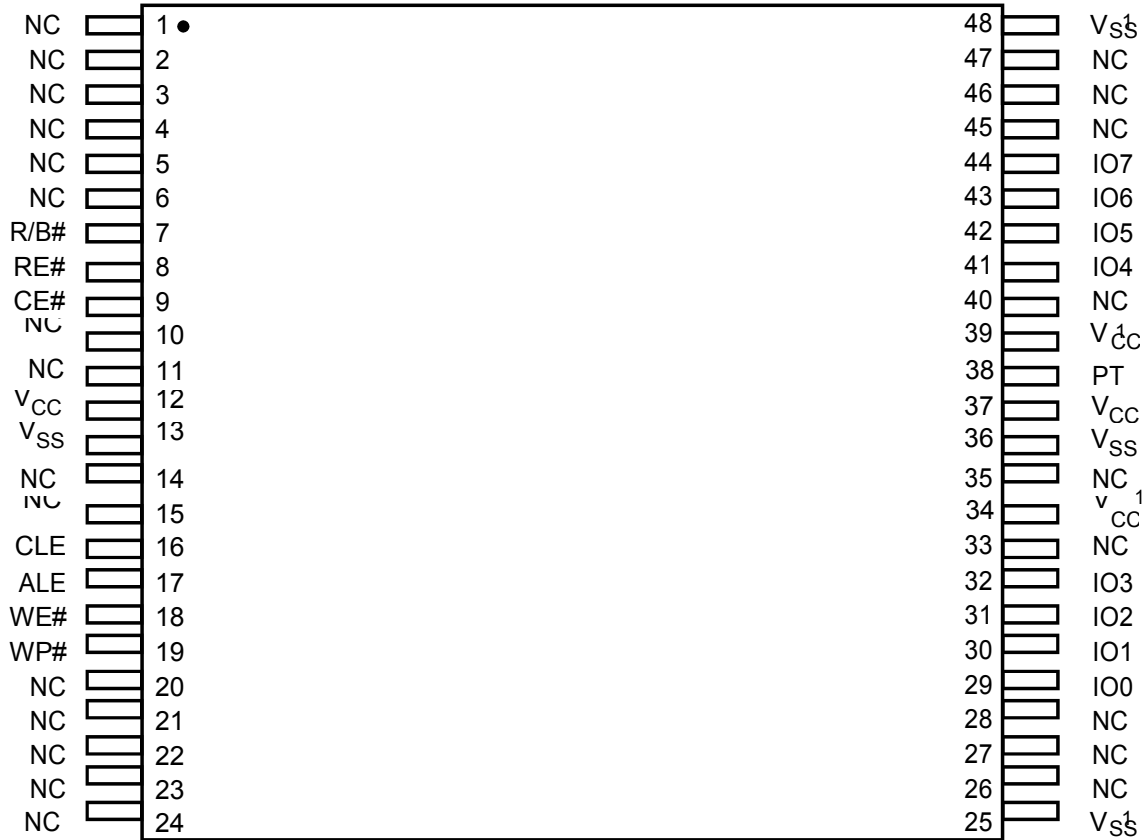

**Note 1.** *These pins might not be connected internally. However, it is recommended to connect these pins to power(or ground) as designated for ONFI compatibility.*



63-ball 9mmx11mm VFBGA

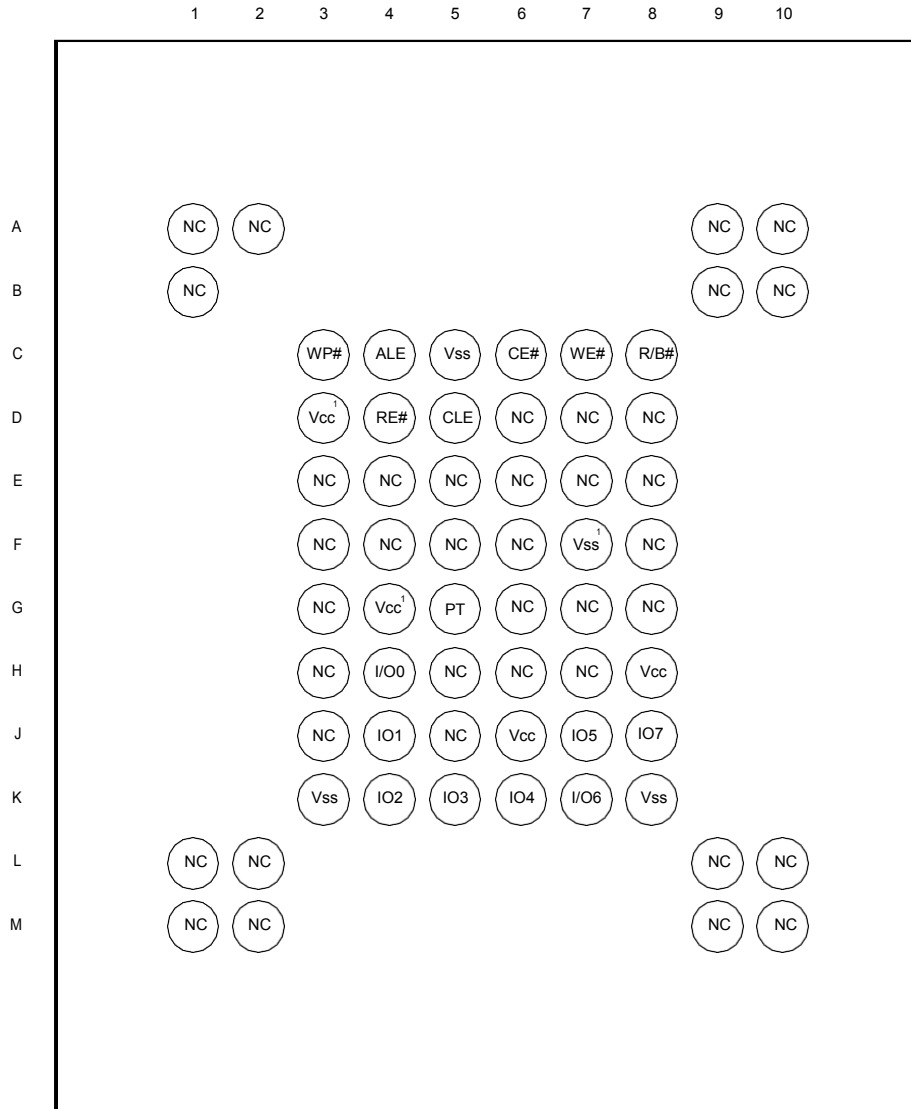

**Note 1.** These pins might not be connected internally; however, it is recommended to connect these pins to power (or ground) as designated for ONFI compatibility.

### 3-1. PIN DESCRIPTIONS

<b>SYMBOL</b>	<b>PIN NAME</b>
<b>I07 - I00</b>	Data I/O port
<b>CE#</b>	Chip Enable (Active Low)
<b>RE#</b>	Read Enable (Active Low)
<b>WE#</b>	Write Enable (Active Low)
<b>CLE</b>	Command Latch Enable
<b>ALE</b>	Address Latch Enable
<b>WP#</b>	Write Protect (Active Low)
<b>PT</b>	PT (Protection) pin connecting to high for entire chip protected and enabling the Block Protection. A weak pull-down internally.
<b>R/B#</b>	Ready/Busy (Open Drain)
<b>VSS</b>	Ground
<b>VCC</b>	Power Supply for Device Operation
<b>NC</b>	Not Connected Internally

**PIN FUNCTIONS**

The MX30LF1G18AC device is a sequential access memory that utilizes multiplexing input of Command/Address/Data.

**I/O PORT: IO7 - IO0**

The IO7 to IO0 pins are for address/command input and data output to/from the device.

**CHIP ENABLE: CE#**

The device goes into low-power Standby Mode when CE# goes high during a read operation and not at busy stage.

The CE# goes low to enable the device to be ready for standard operation. When the CE# goes high, the device is deselected. However, when the device is at busy stage, the device will not go to standby mode when CE# pin goes high.

**READ ENABLE: RE#**

The RE# (Read Enable) allows the data to be output by a tREA time after the falling edge of RE#. The internal address counter is automatically increased by one at the falling edge of RE#.

**WRITE ENABLE: WE#**

When the WE# goes low, the address/data/command are latched at the rising edge of WE#.

**COMMAND LATCH ENABLE: CLE**

The CLE controls the command input. When the CLE goes high, the command data is latched at the rising edge of the WE#.

**ADDRESS LATCH ENABLE: ALE**

The ALE controls the address input. When the ALE goes high, the address is latched at the rising edge of WE#.

**WRITE PROTECT: WP#**

The WP# signal keeps low and then the memory will not accept the program/erase operation. It is recommended to keep WP# pin low during power on/off sequence. Please refer to **Figure 37. Power On/Off Sequence**.

**READY/Busy: R/B#**

The R/B# is an open-drain output pin. The R/B# outputs the ready/busy status of read/program/erase operation of the device. When the R/B# is at low, the device is busy for read or program or erase operation. When the R/B# is at high, the read/program/erase operation is finished.

Please refer to **8-1. R/B#: Termination for The Ready/Busy# Pin (R/B#)** for details.

**PT: Protection**

When the PT pin is high at power on, the whole chip is protected even the WP# is at high; the un-protection procedure (through BP bits setting) is necessary before any program/erase operation. When the PT pin is connected to low or floating, the function of block protection is disabled.

#### 4. BLOCK DIAGRAM

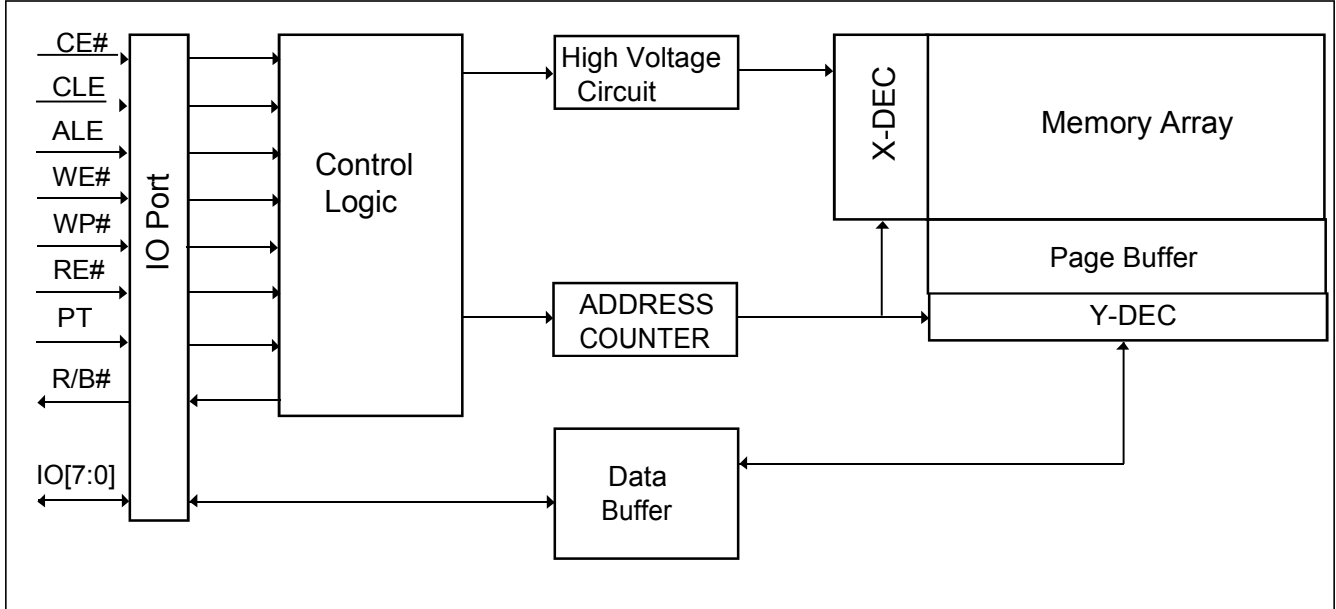

## 5. SCHEMATIC CELL LAYOUT AND ADDRESS ASSIGNMENT

MX30LF1G18AC is composed by 64 pages of (2,048+64)-byte in two NAND strings structure with 32 serial connected cells in each string. Each page has an additional 64 bytes for ECC and other purposes. The device has an on-chip buffer of 2,112 bytes for data load and access. Each 2K-Byte page has the two area, one is the main area which is 2048-bytes and the other is spare area which is 64-byte.

There are four address cycles for the address allocation, please refer to the table below.

**Table 1. Address Allocation**

Addresses	IO7	IO6	IO5	IO4	IO3	IO2	IO1	IO0
<b>Column address - 1st cycle</b>	A7	A6	A5	A4	A3	A2	A1	A0
<b>Column address - 2nd cycle</b>	L	L	L	L	A11	A10	A9	A8
<b>Row address - 3rd cycle</b>	A19	A18	A17	A16	A15	A14	A13	A12
<b>Row address - 4th cycle</b>	A27	A26	A25	A24	A23	A22	A21	A20

## 6. DEVICE OPERATIONS

### 6-1. Address Input/Command Input/Data Input

Address input bus operation is for address input to select the memory address. The command input bus operation is for giving command to the memory. The data input bus is for data input to the memory device.

Figure 2. AC Waveforms for Command / Address / Data Latch Timing

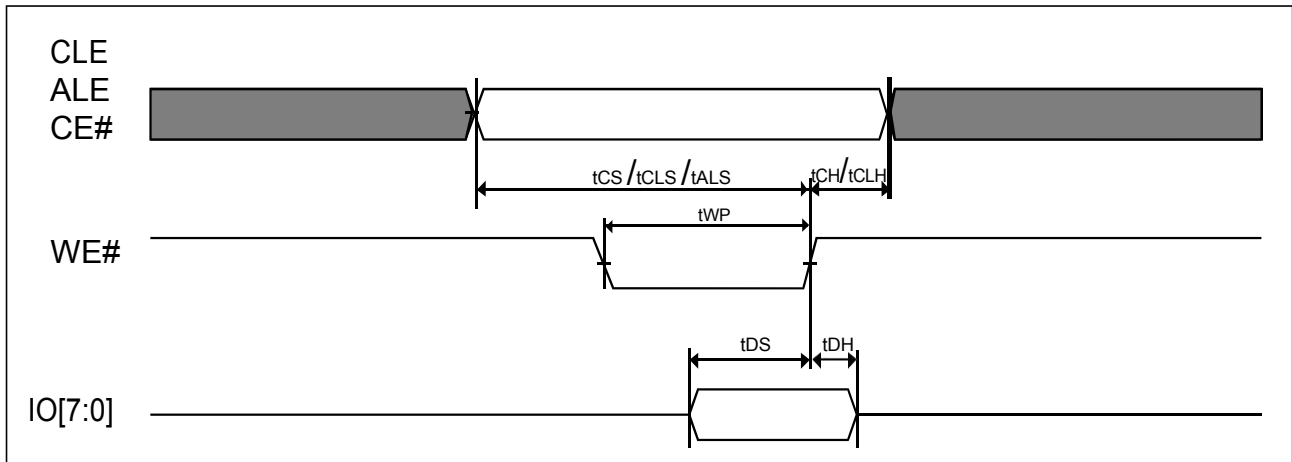

Figure 3. AC Waveforms for Address Input Cycle

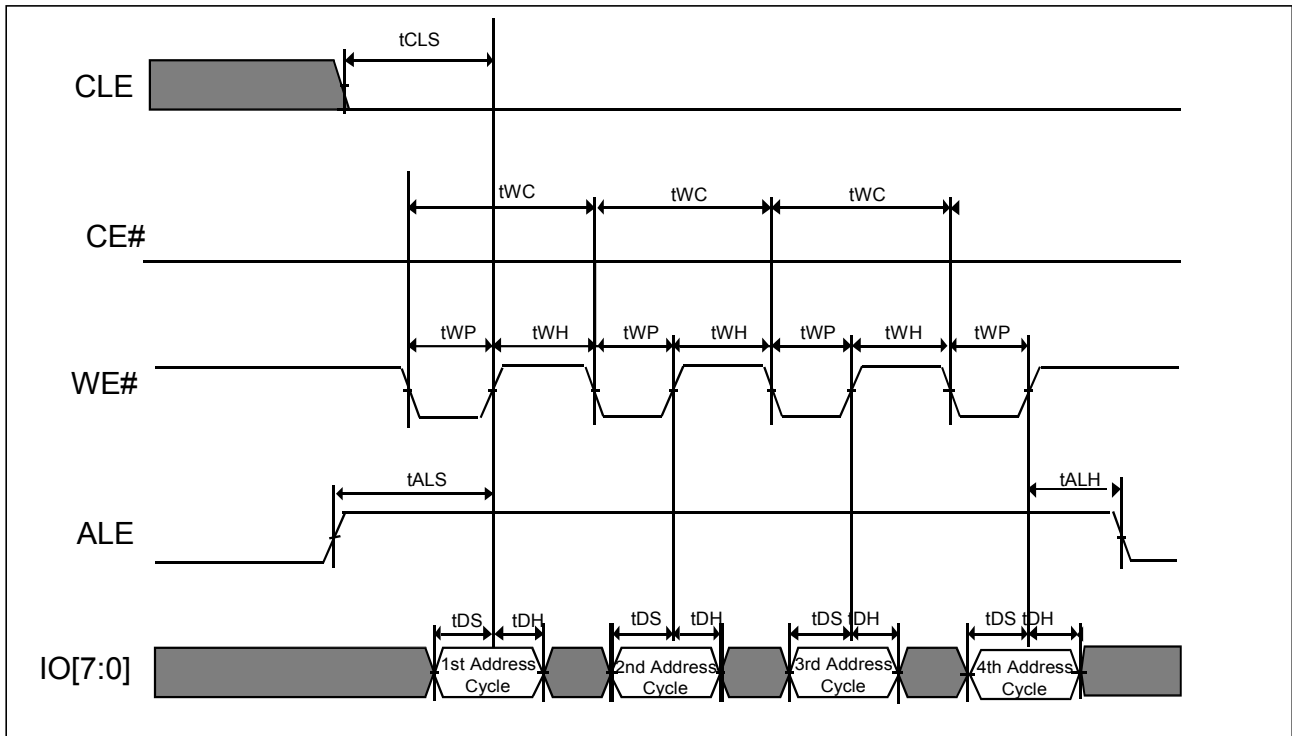

Figure 4. AC Waveforms for Command Input Cycle

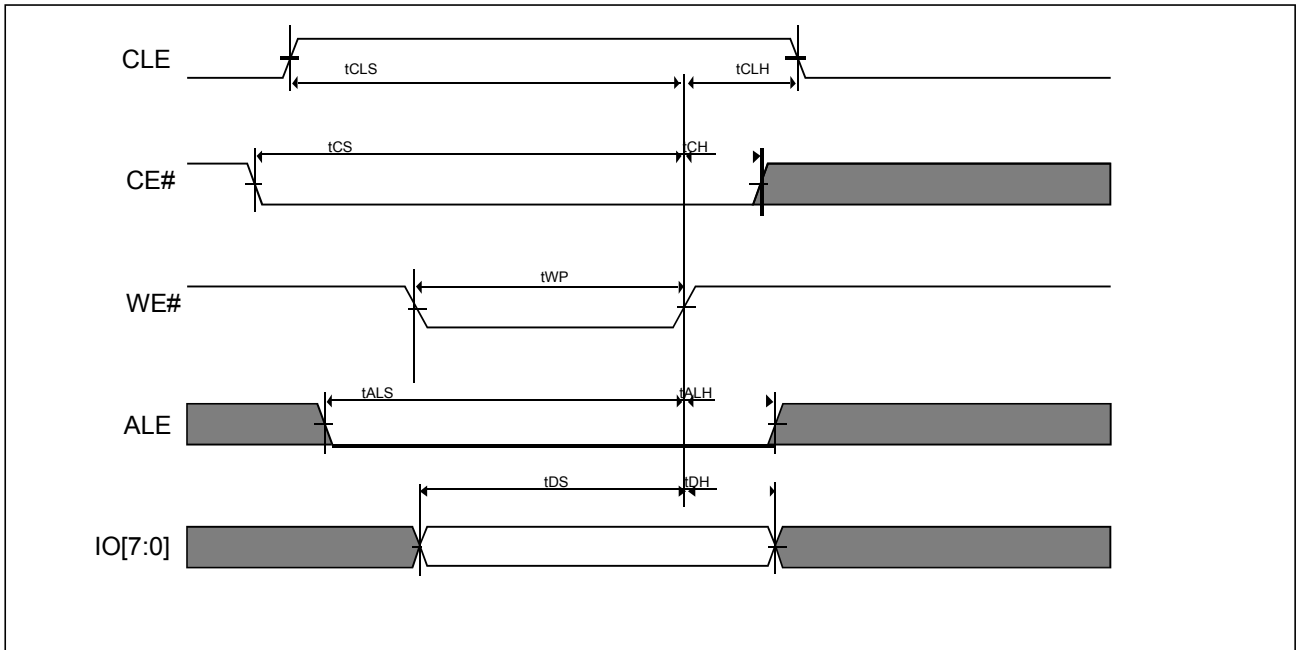
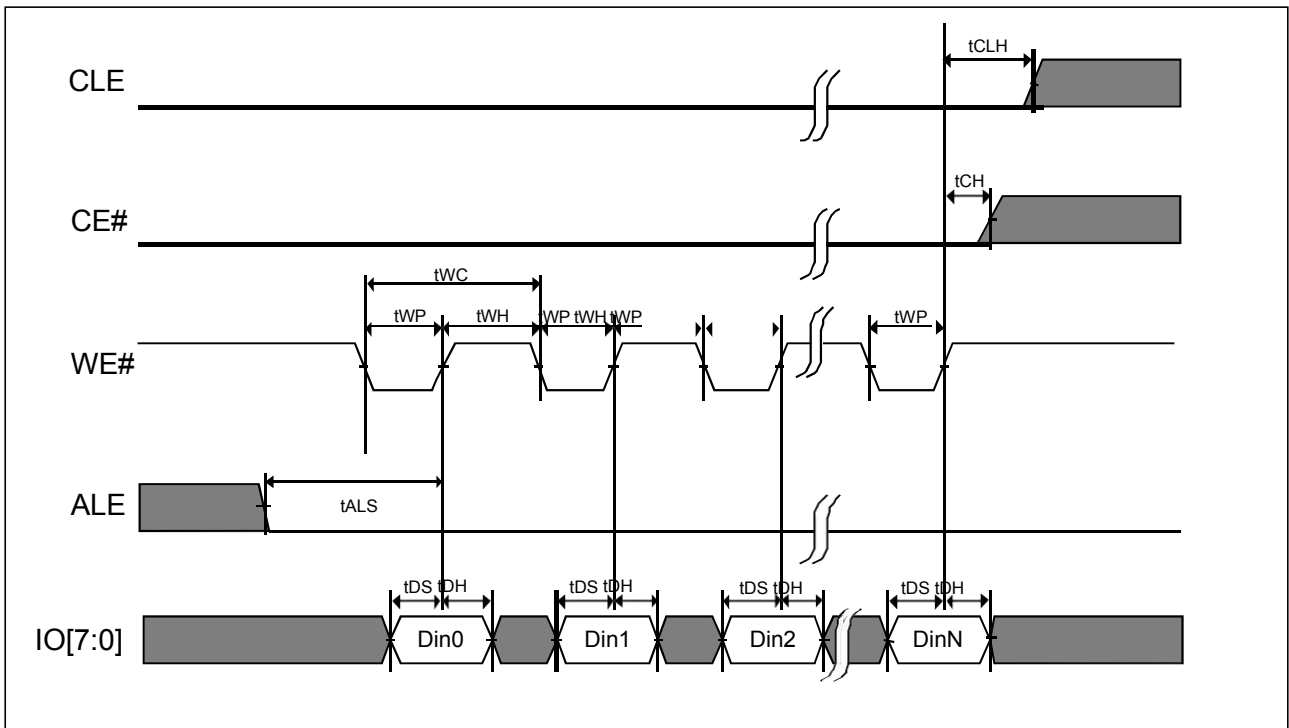

Figure 5. AC Waveforms for Data Input Cycle



## 6-2. Page Read

The MX30LF1G18AC array is accessed in Page of 2,112 bytes. External reads begins after the R/B# pin goes to READY.

The Read operation may also be initiated by writing the 00h command and giving the address (column and row address) and being confirmed by the 30h command, the MX30LF1G18AC begins the internal read operation and the chip enters busy state. The data can be read out in sequence after the chip is ready. Refer to **Figure 6. AC Waveforms for Read Cycle**.

If the host side uses a sequential access time ( $t_{RC}$ ) of less than 30ns, the data can be latched on the next falling edge of RE# as the waveform of EDO mode (**Figure 9-2. AC Waveforms for Sequential Data Out Cycle (After Read) - EDO Mode**).

To access the data in the same page randomly, a command of 05h may be written and only column address following and then confirmed by E0h command.

**Figure 6. AC Waveforms for Read Cycle**

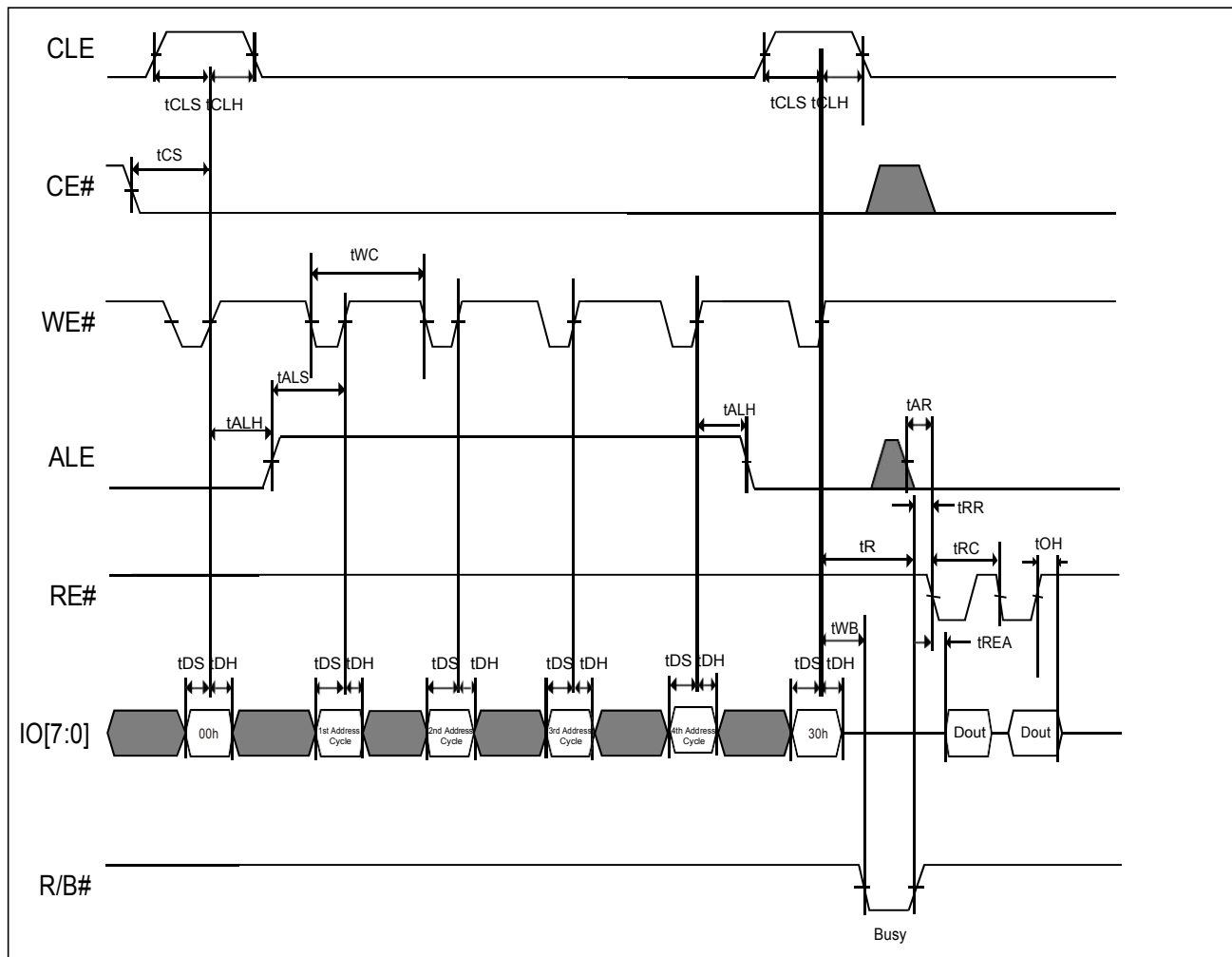



Figure 7. AC Waveforms for Read Operation (Intercepted by CE#)

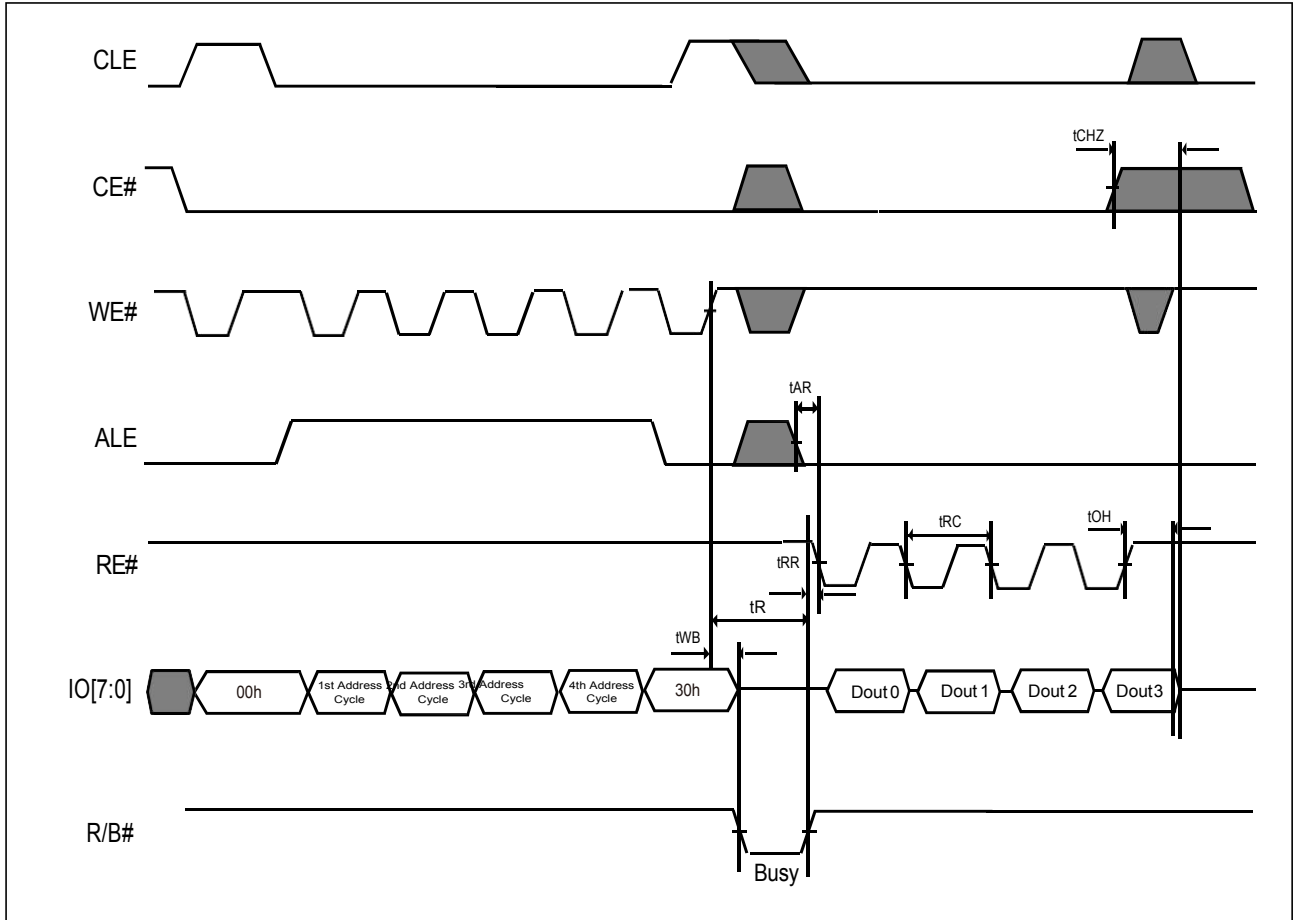
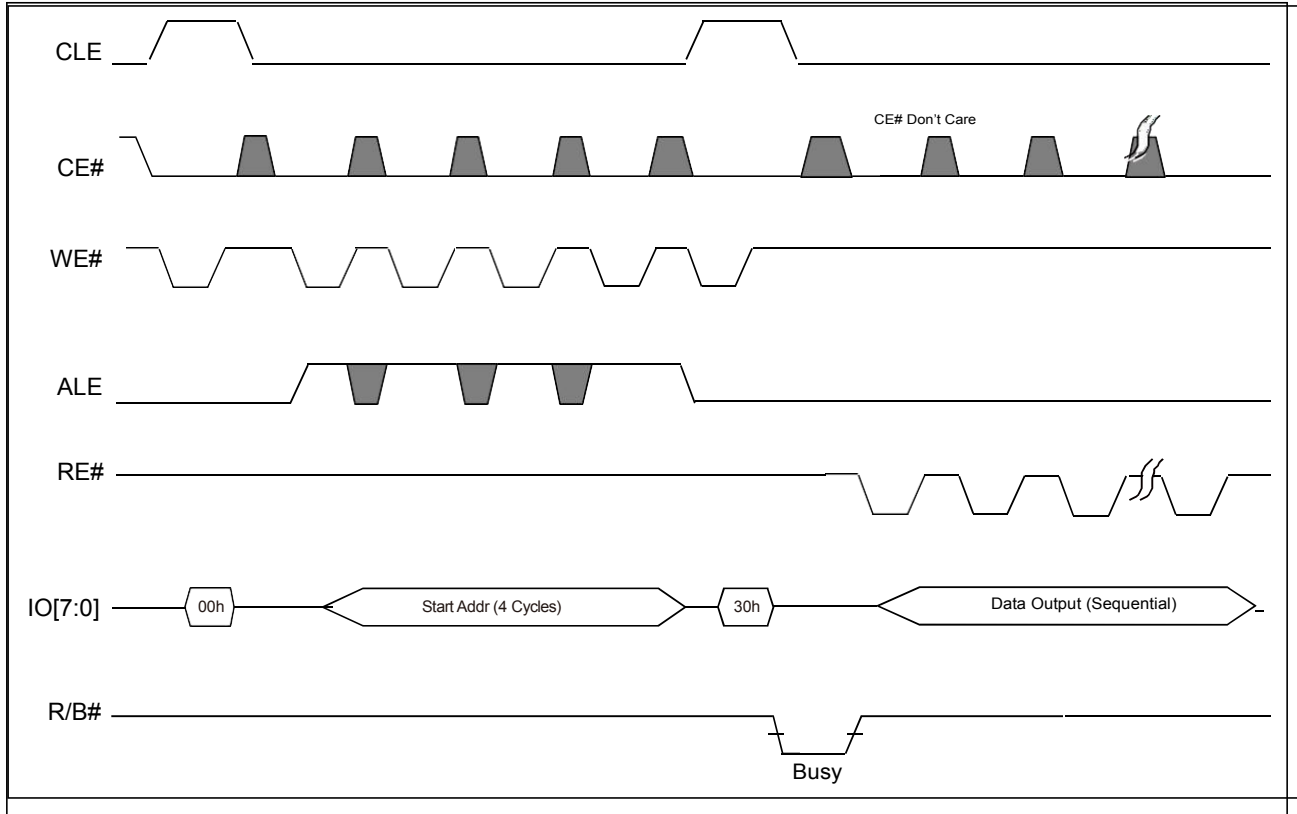

Figure 8. AC Waveforms for Read Operation (with CE# Don't Care)



**Note:** The CE# "Don't Care" feature may simplify the system interface, which allows controller to directly download the code from flash device, and the CE# transitions will not stop the read operation during the latency time.

Figure 9-1. AC Waveforms for Sequential Data Out Cycle (After Read)

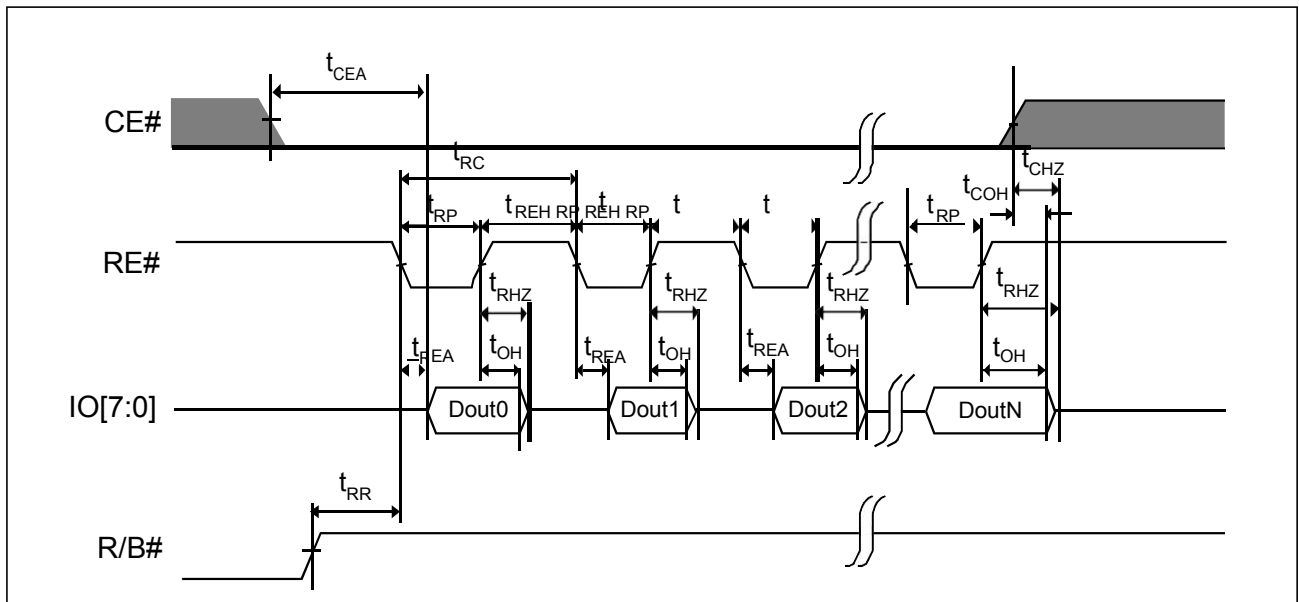
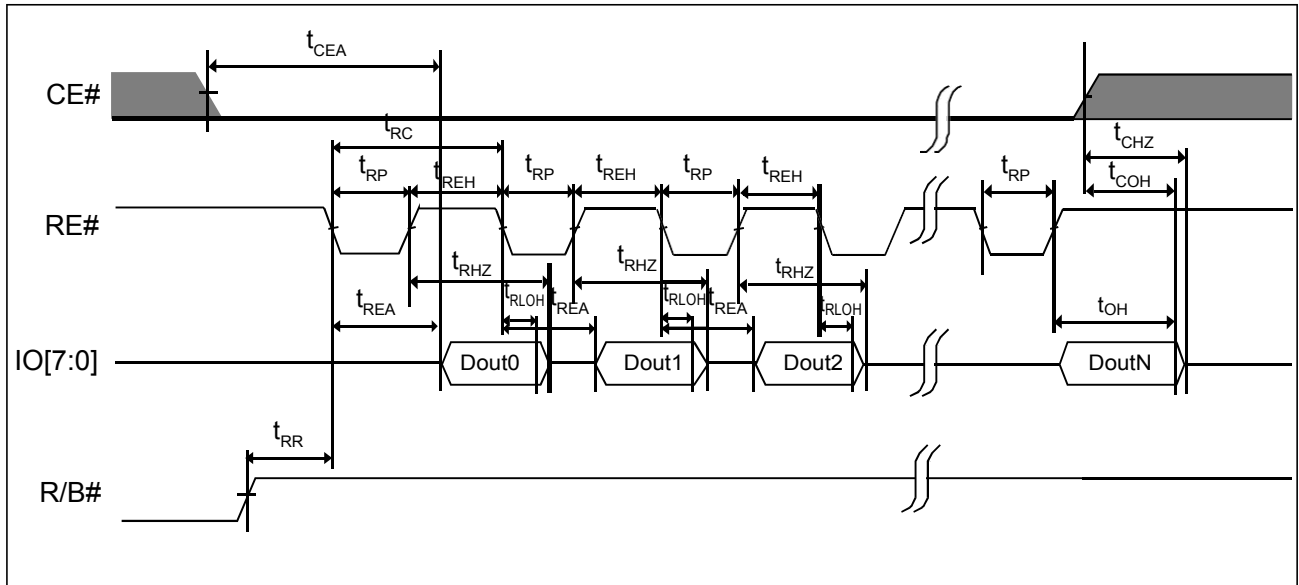
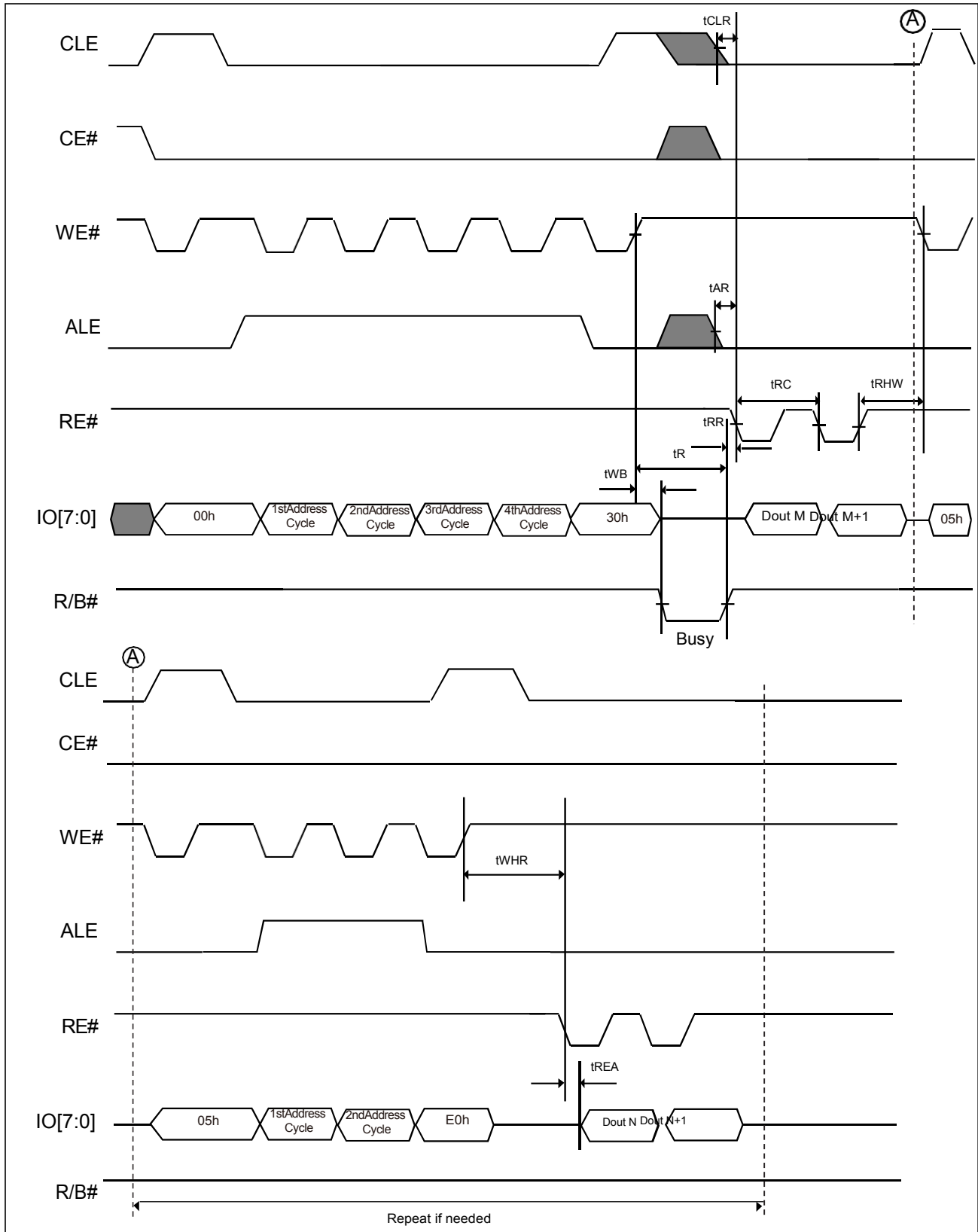

Figure 9-2. AC Waveforms for Sequential Data Out Cycle (After Read) - EDO Mode



**Figure 10. AC Waveforms for Random Data Output**



### 6-3. Cache Read Sequential

The cache read sequential operation is for throughput enhancement by using the internal cache buffer. It allows the consecutive pages to be read-out without giving next page address, which reduces the latency time from  $t_R$  to  $t_{RCBSY}$  between pages or blocks. While the data is read out on one page, the data of next page can be read into the cache buffer.

After writing the 00h command, the column and row address should be given for the start page selection, and followed by the 30h command for address confirmation. After that, the CACHE READ operation starts after a latency time  $t_R$  and following a 31h command with the latency time of  $t_{RCBSY}$ , the data can be read-out sequentially from 1<sup>st</sup> column address (A[11:0]=000h) without giving next page address input. The 31h command is necessary to confirm the next cache read sequential operation and followed by a  $t_{RCBSY}$  latency time before next page data is necessary. The CACHE READ SEQUENTIAL command is also valid for the consecutive page cross block.

The random data out (05h-E0h) command set is available to change the column address of the current page data in the cache register.

The user can check the chip status by the following method:

- R/B# pin ("0" means the data is not ready, "1" means the user can read the data)
- Status Register (SR[6] functions the same as R/B# pin, SR[5] indicates the internal chip operation, "0" means the chip is in internal operation and "1" means the chip is idle.) Status Register can be checked after the Read Status command (70h) is issued. Command 00h should be given to return to the cache read sequential operation.

To confirm the last page to be read-out during the cache read sequential operation, a 3Fh command is needed to replace the 31h command prior to the last data-out.

Figure 11-1. AC Waveforms for Cache Read Sequential

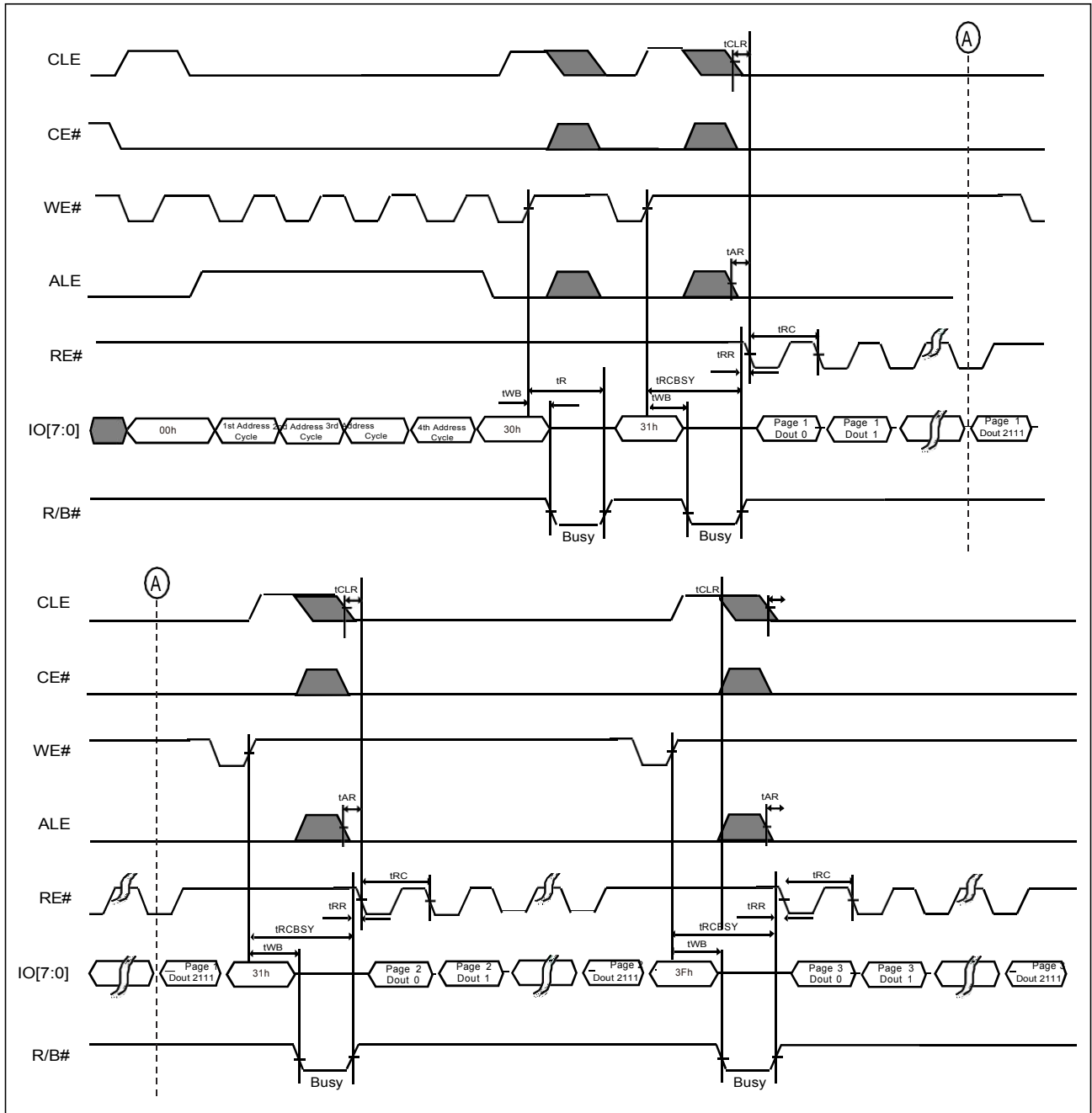

## 6-4. Cache Read Random

The main difference from the Cache Read Sequential operation is the Cache Read Random operation may allow the random page to be read-out with cache operation not just for the consecutive page only.

After writing the 00h command, the column and row address should be given for the start page selection, and followed by the 30h command for address confirmation. The column address is ignored in the cache read random operation. And then, the CACHE READ RANDOM operation starts after a latency time  $t_R$  and following a 00h command with the selected page address and following a 31h command, the data can be read-out sequentially from the 1<sup>st</sup> column address ( $A[11:0] = 000h$ ) after the latency time of  $t_{RCBSY}$ . After the previous selected page data out, a new selected page address can be given by writing the 00h-31h command set again. The CACHE READ RANDOM command is also valid for the consecutive page cross block.

The random data out (05h-E0h) command set is available to change the column address of the current page data in the cache register.

The user can check the chip status by the following method:

- R/B# pin ("0" means the data is not ready, "1" means the user can read the data)
- Status Register can be checked after the Read Status command (70h) is issued. (SR[6] behaves the same as R/B# pin, SR[5] indicates the internal chip operation, "0" means the chip is in internal operation and "1" means the chip is idle.) Command 00h should be given to return to the cache read operation.

To confirm the last page to be read-out during the cache read operation, a 3Fh command is needed to replace the 31h command prior to the last data-out.

Figure 11-2. AC Waveforms for Cache Read Random

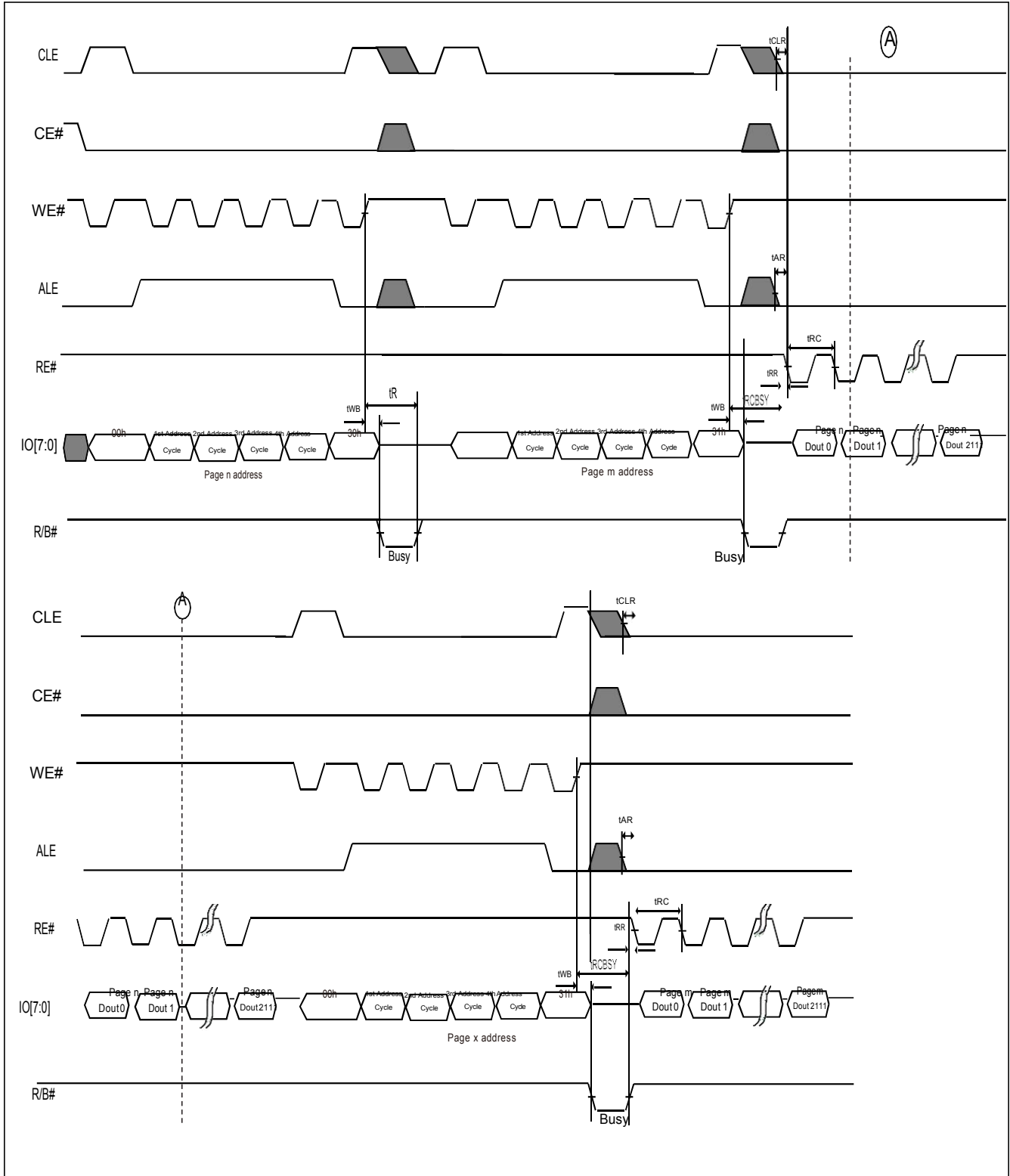



## 6-5. Page Program

The memory is programmed by page, which is 2,112 bytes. After Program load command (80h) is issued and the row and column address is given, the data will be loaded into the chip sequentially. Random Data Input command (85h) allows multi-data load in non-sequential address. After data load is complete, program confirm command (10h) is issued to start the page program operation. The page program operation in a block should start from the low address to high address. Partial program in a page is allowed up to 4 times. However, the random data input mode for programming a page is allowed and number of times is not limited.

The status of the program completion can be detected by R/B# pin or Status register bit SR[6].

The program result is shown in the chip status bit (SR[0]). SR[0] = 1 indicates the Page Program is not successful and SR[0] = 0 means the program operation is successful.

During the Page Program progressing, only the read status register command and reset command are accepted, others are ignored.

**Figure 12. AC Waveforms for Program Operation after Command 80H**

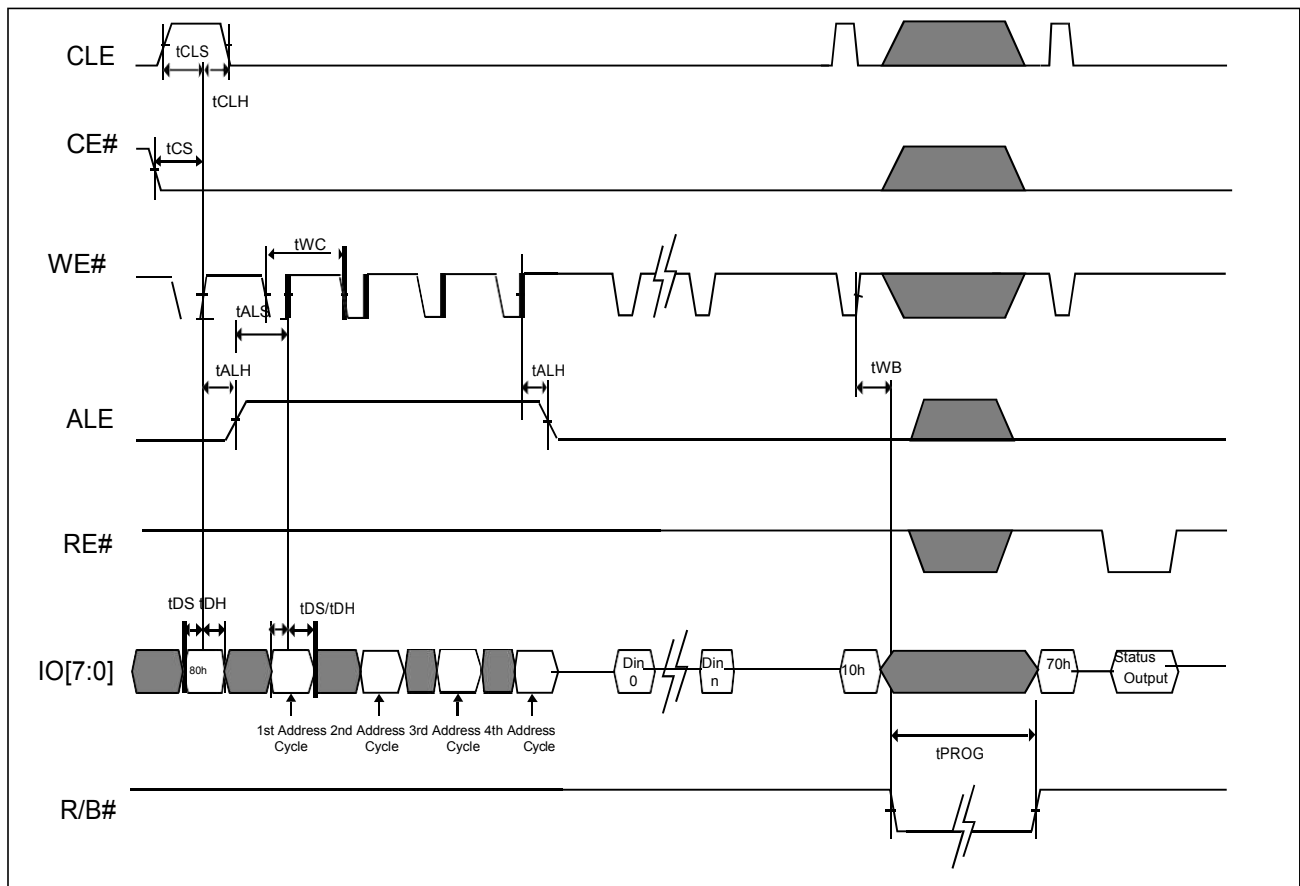
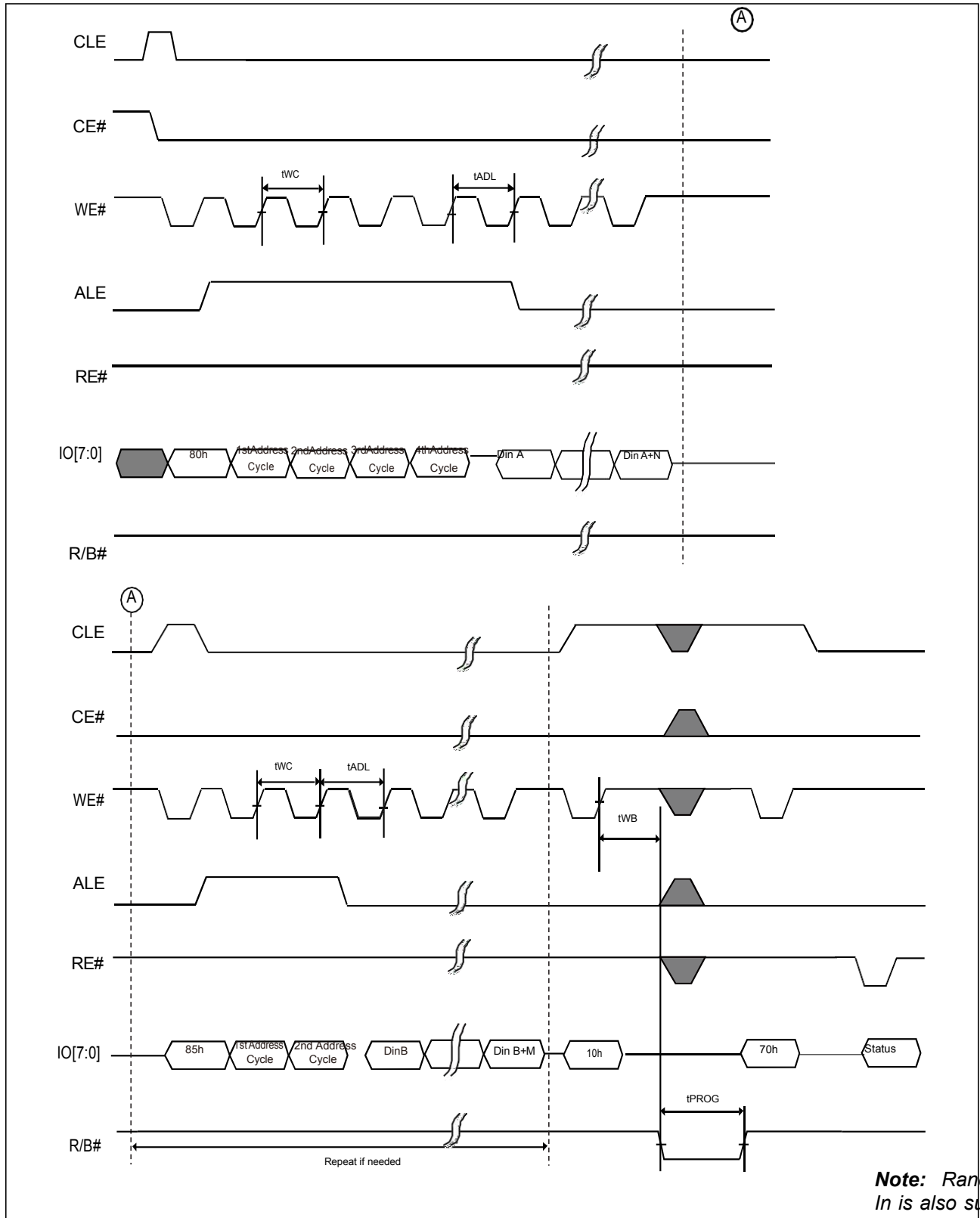

Figure 13. AC Waveforms for Random Data In (For Page Program)





IO0 = 0; Pass IO0 = 1; Fail

**MX30LF1G18AC**

---

Figure 14. AC Waveforms for Program Operation with CE# Don't Care

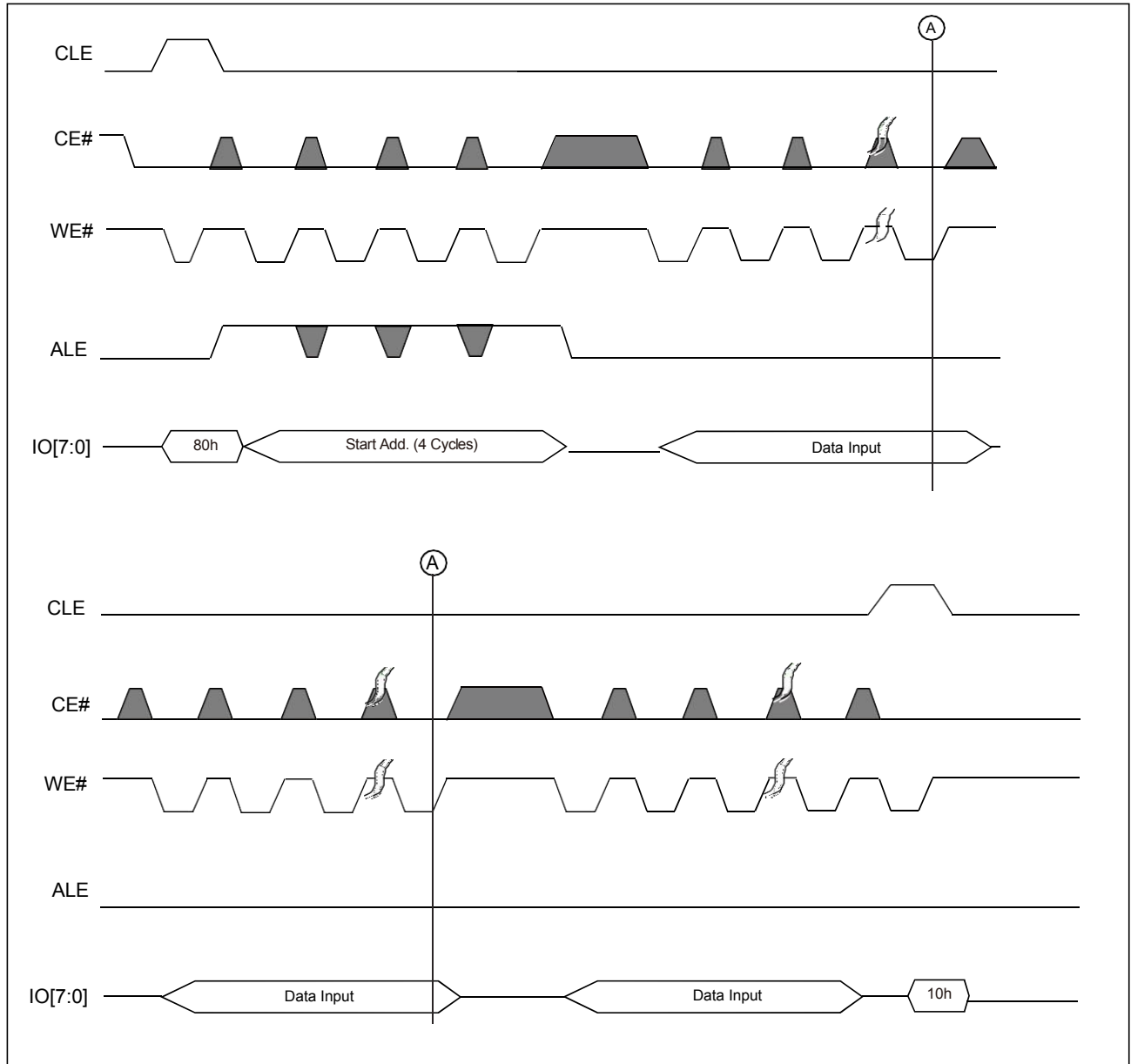

**Note:** The CE# "Don't Care" feature may simplify the system interface, which allows the controller to directly write data into flash device, and the CE# transitions will not stop the program operation during the latency time.

## 6-6. Cache Program

The cache program feature enhances the program performance by using the cache buffer of 2,112-byte. The serial data can be input to the cache buffer while the previous data stored in the buffer are programming into the memory cell. Cache Program command sequence is almost the same as page program command sequence. Only the Program Confirm command (10h) is replaced by cache Program command (15h).

After the Cache Program command (15h) is issued. The user can check the status by the following methods.

- R/B# pin
- Cache Status Bit (SR[6] = 0 indicates the cache is busy; SR[6] = 1 means the cache is ready).

The user can issue another Cache Program Command Sequence after the Cache is ready. The user can always monitor the chip state by Ready/Busy Status Bit (SR[5]). The user can issues either program confirm command (10h) or cache program command (15h) for the last page if the user monitor the chip status by issuing Read Status Command (70h).

However, if the user only monitors the R/B# pin, the user needs to issue the program confirm command (10h) for the last page.

The user can check the Pass/Fail Status through P/F Status Bit (SR[0]) and Cache P/F Status Bit (SR[1]). SR[1] represents Pass/Fail Status of the previous page. SR[1] is updated when SR[6] change from 0 to 1 or Chip is ready. SR[0] shows the Pass/Fail status of the current page. It is updated when SR[5] change from "0" to "1" or the end of the internal programming. For more details, please refer to the related waveforms.

Figure 15-1. AC Waveforms for Cache Program

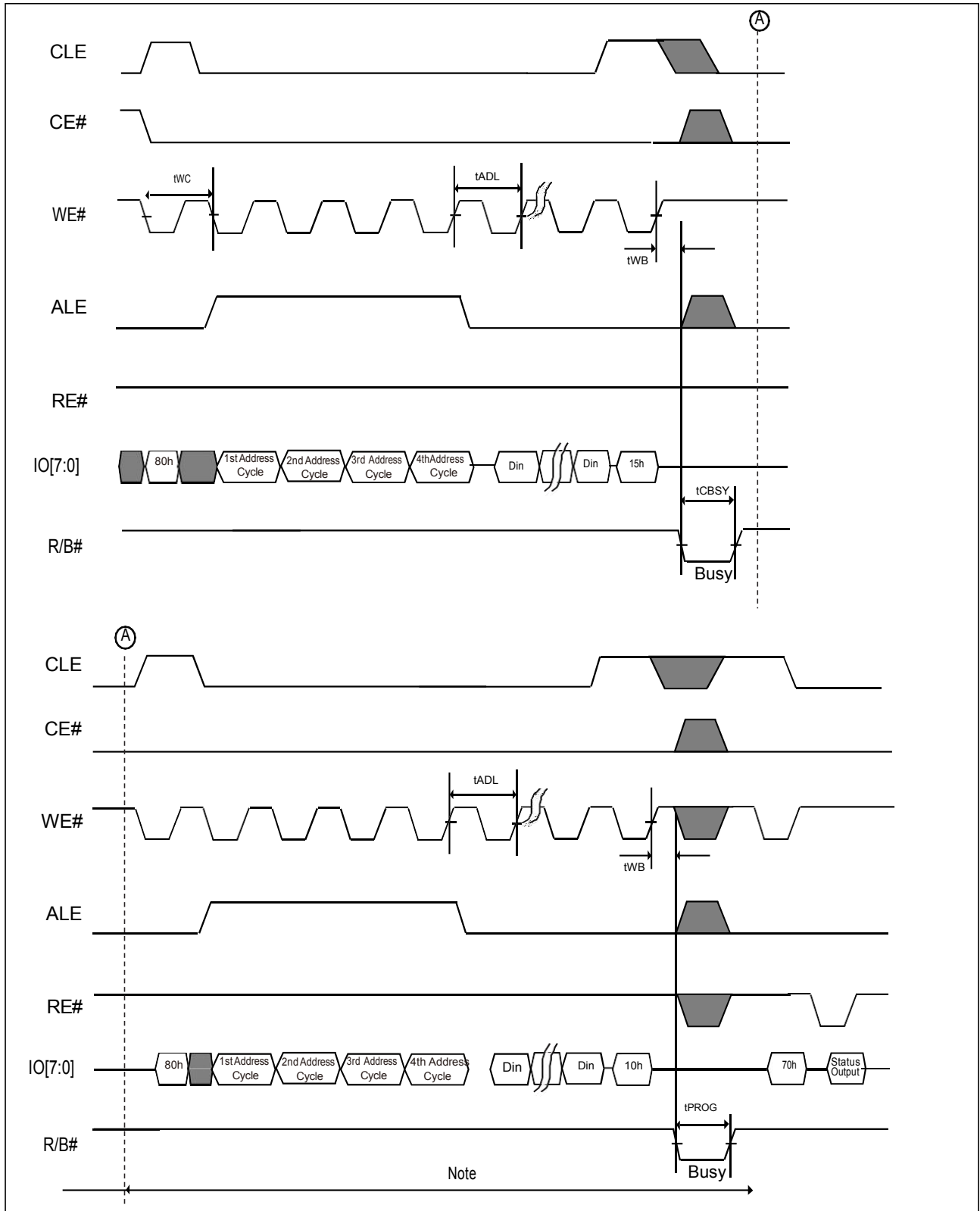



*Note: It indicates the last page Input & Program.*

Figure 15-2. AC Waveforms for Sequence of Cache Program

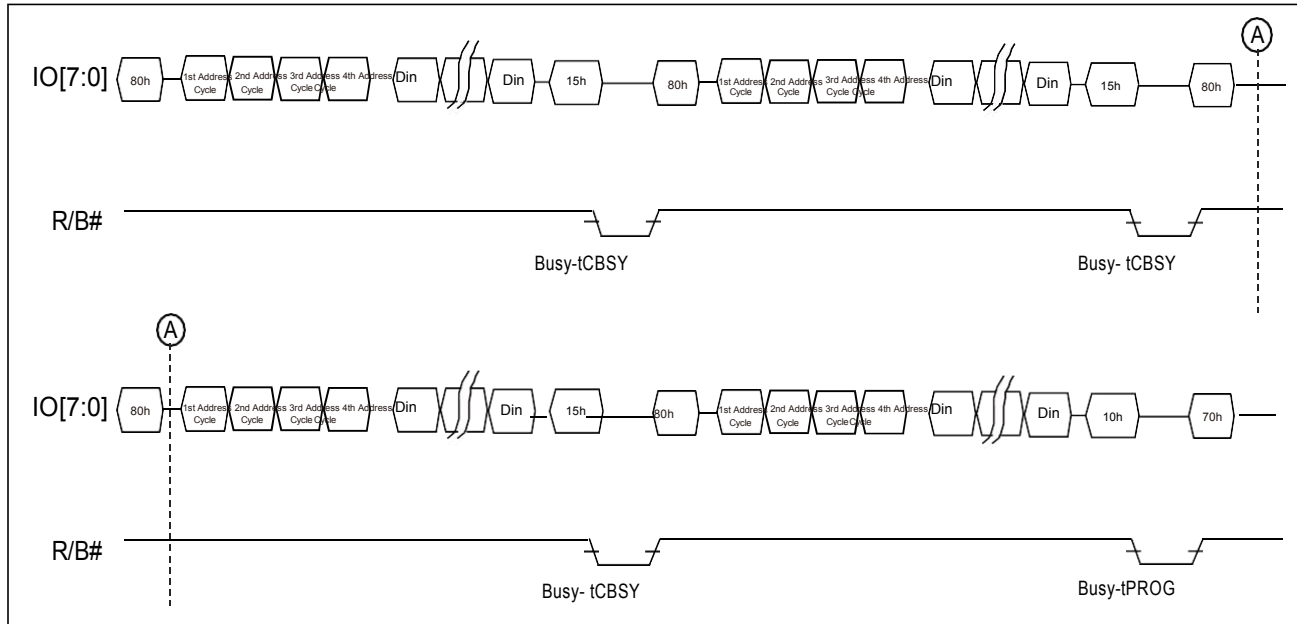

**Note:**  $t_{PROG} = Page_{(Last)} \text{ programming time} + Page_{(Last-1)} \text{ programming time} - \text{Input cycle time of command \& address} - \text{Data loading time of page}_{(Last)}$ .



### 6-7. Block Erase

The MX30LF1G18AC supports a block erase command. This command will erase a block of 64 pages associated with the most significant address bits.

The completion of the erase operation can be detected by R/B# pin or Status register bit (IO6). Recommend to check the status register bit IO0 after the erase operation completes.

During the erasing process, only the read status register command and reset command can be accepted, others are ignored.

**Figure 16. AC Waveforms for Erase Operation**

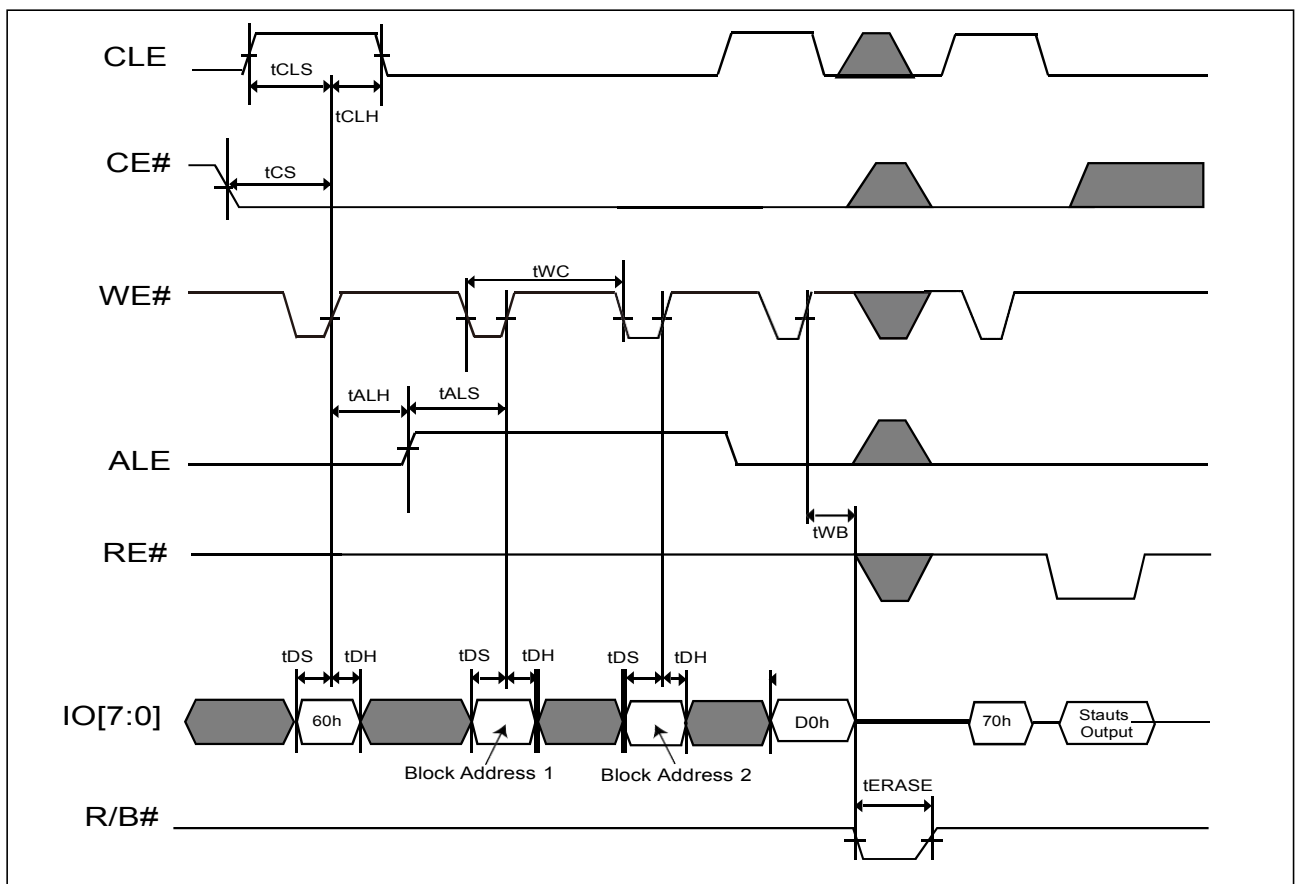

## 6-8. ID Read

The device contains ID codes that identify the device type and the manufacturer. The ID READ command sequence includes one command Byte (90h), one address byte (00h). The Read ID command 90h may provide the manufacturer ID (C2h) of one-byte and device ID (F1h) of one-byte, also Byte2, Byte3, and Byte4 ID code are followed.

The device support ONFI Parameter Page Read, by sending the ID Read (90h) command and following one byte address (20h), the four-byte data returns the value of 4Fh-4Eh-46h-49h for the ASCII code of "O"- "N"- "F"- "I" to identify the ONFI parameter page.

**Table 2. ID Codes Read Out by ID Read Command 90H**

ID Codes	1Gb, x8, 3V
Byte0-Manufacturer	C2h
Byte1: Device ID	F1h
Byte2	80h
Byte3	95h
Byte4	02h

**Table 3. The Definition of Byte2-Byte4 of ID Table**

Terms	Description	IO7	IO6	IO5	IO4	IO3	IO2	IO1	IO0
<b>Byte 2</b>									
<b>Die Number</b>	1							0	0
	2							0	1
<b>Cell Structure</b>	SLC					0	0		
<b># of Concurrently Programmed page</b>	1			0	0				
	2			0	1				
<b>Interleaved operations between Multiple die</b>	Not supported		0						
<b>Cache Program</b>	Supported	1							
<b>Byte 3</b>									
<b>Page size (Exclude spare)</b>	2KB							0	1
<b>Spare area size (Per 512B)</b>	16B						1		
<b>Block size (Exclude spare)</b>	128KB			0	1				
<b>Organization</b>	x8		0						
<b>Sequential Read Cycle Time</b>	25ns	0				0			
	20ns	1				0			
<b>Byte 4</b>									
<b>ECC level requirement</b>	4-bit ECC/528B							1	0
<b>#Plane per CE</b>	1					0	0		
	2					0	1		
	4					1	0		
<b>Plane size</b>	1Gb		0	0	0				
	2Gb		1	0	1				
<b>Reserved</b>		0							



## 6-9. Status Read

The MX30LF1G18AC provides a status register that outputs the device status by writing a command code 70h, and then the IO pins output the status at the falling edge of CE# or RE# which occurs last. Even though when multiple flash devices are connecting in system and the R/B#pins are common-wired, the two lines of CE# and RE# may be checked for individual devices status separately.

The status read command 70h will keep the device at the status read mode unless next valid command is issued. The resulting information is outlined in **Table 4** as below.

**Table 4. Status Output**

Pin	Status	Related Mode	Value	
SR[0]	Chip Status	Page Program, Cache Program (Page N), Block Erase	0: Passed	1: Failed
SR[1]	Cache Program Result	Cache Program (Page N-1)	0: Passed	1: Failed
SR[2-4]	Not Used			
SR[5]	Ready / Busy (For P/E/R Controller)	Cache Program/Cache Read operation, other Page Program/Block Erase/Read are same as IO6 ( <b>Note 1</b> )	0: Busy	1: Ready
SR[6]	Ready / Busy	Page Program, Block Erase, Cache Program, Read, Cache Read ( <b>Note 2</b> )	0: Busy	1: Ready
SR[7]	Write Protect	Page Program, Block Erase, Cache Program, Read	0: Protected	1: Unprotected

**Notes:**

1. During the actual programming operation, the SR[5] is "0" value; however, when the internal operation is completed during the cache mode, the SR[5] returns to "1".
2. The SR[6] returns to "1" when the internal cache is available to receive new data. The SR[6] value is consistent with the R/B#.

The following is an example of a HEX data bit assignment:

**Figure 18. Bit Assignment (HEX Data)**

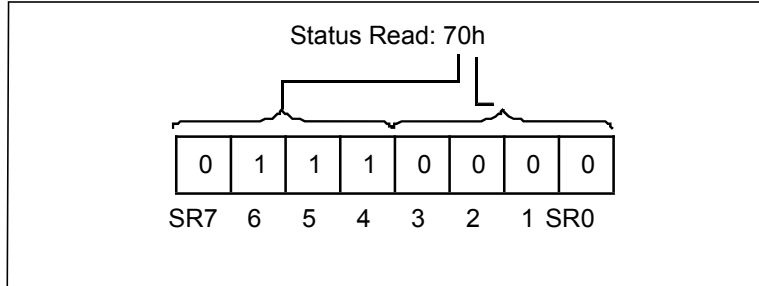

**Figure 19. AC Waveforms for Status Read Operation**

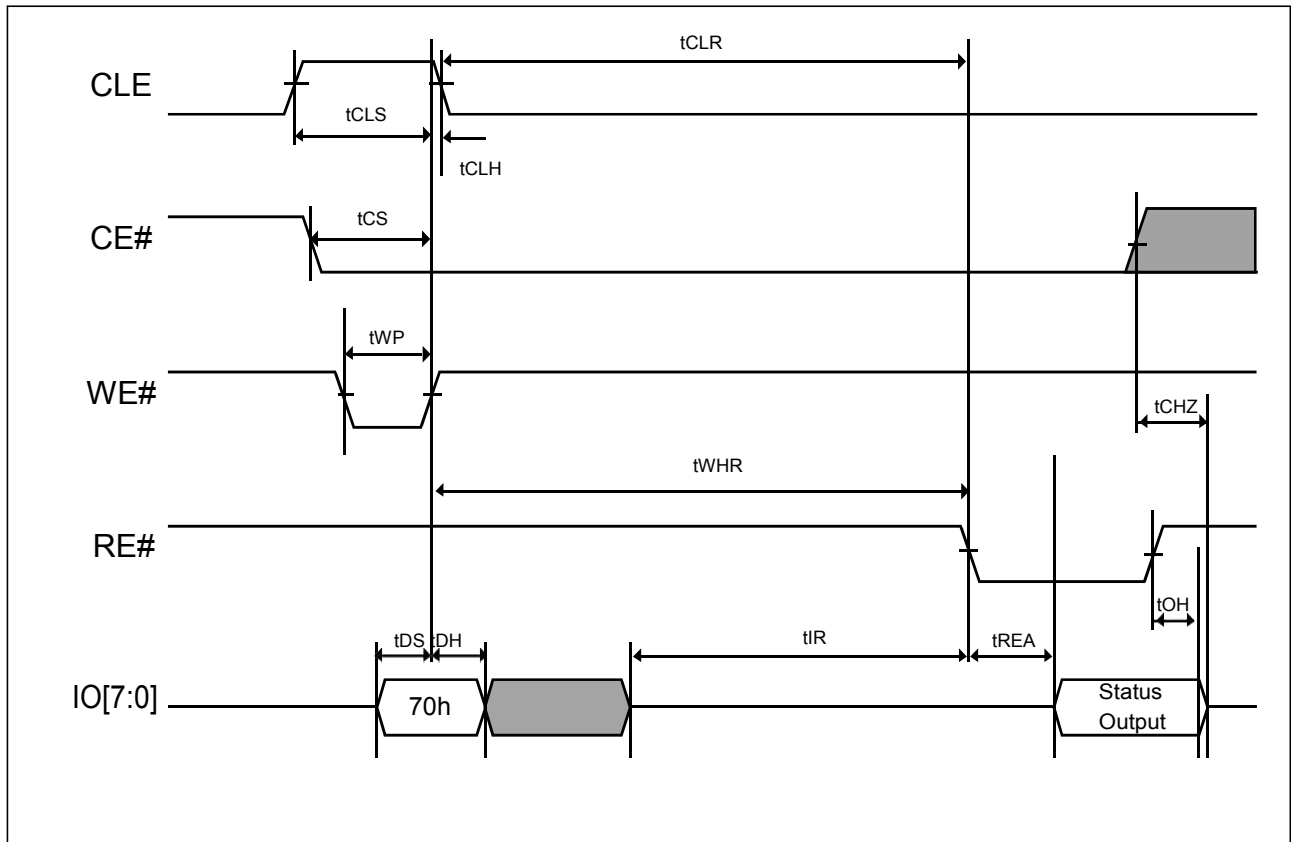

## 6-10. Block Protection Status Read

The Block Protection Status Read command (7Ah) may check the protect/un-protect status of blocks. The status output is shown in **Table 5. Block Protection Status Output** and the address cycle is referred to **Table 6. Address Cycle Definition of Block**.

**Table 5. Block-Protection Status Output**

Block-Protection Status	IO[7:3]	IO2(PT#)	IO1(SP#)	IO0(SP)
Block is protected, and device is solid-protected	x	0	0	1
Block is protected, and device is not solid-protected	x	0	1	0
Block is un-protected, and device is solid-protected	x	1	0	1
Block is un-protected, and device is not solid-protected	x	1	1	0

**Note:** *SP stands for Solid-protected. Once the SP bit sets as 1, the rest of the protection bits (BPx bits, Invert bit, Complementary bit) cannot be changed during the current power cycle.*

**Table 6. Address Cycle Definition of Block**

Address Cycle	IO7	IO6	IO5	IO4	IO3	IO2	IO1	IO0
Block Address 1	A19	A18	L	L	L	L	L	L
Block Address 2	A27	A26	A25	A24	A23	A22	A21	A20

Figure 20. AC Waveforms for Block Protection Status Read

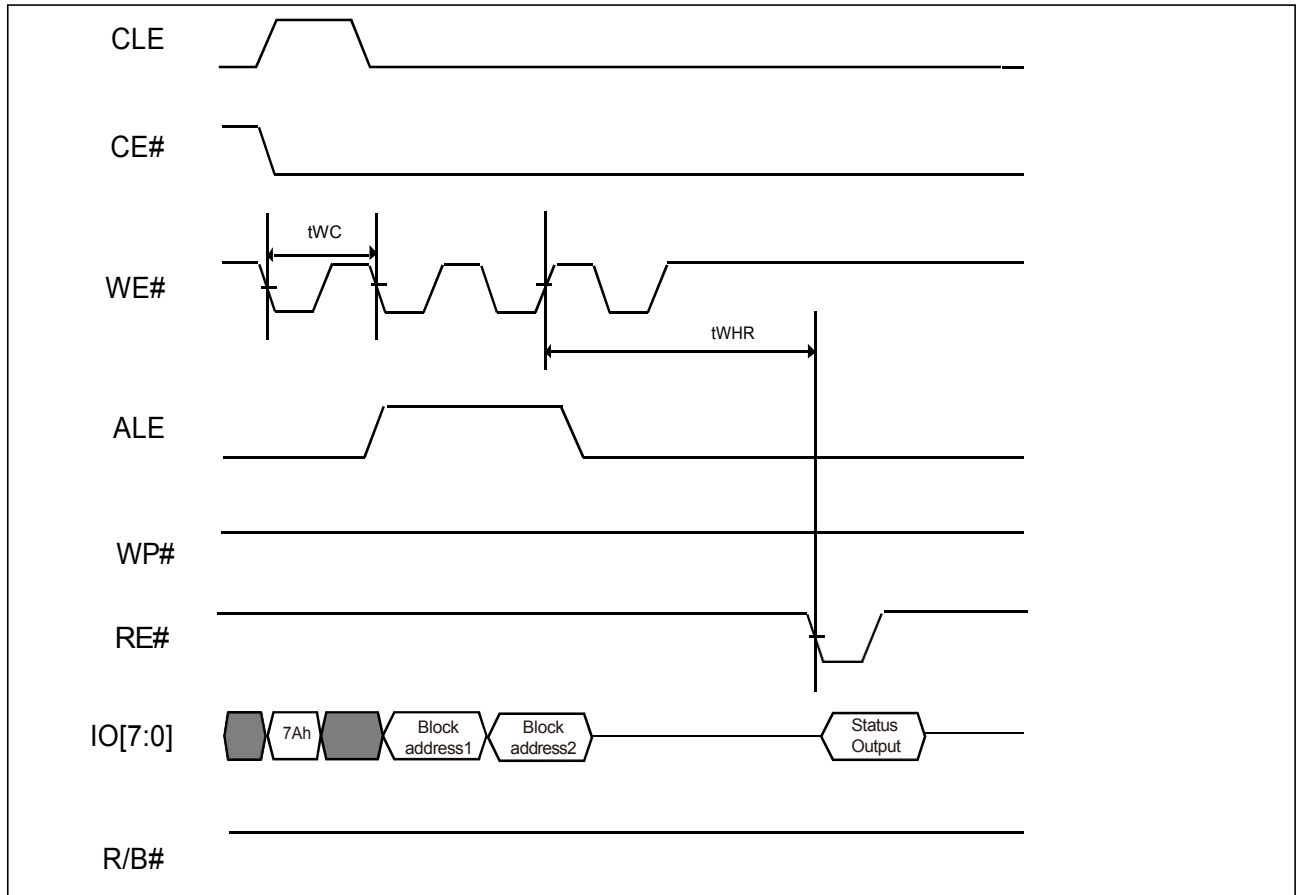



### 6-11. Reset

The reset command FFh resets the read/program/erase operation and clear the status register to be E0h (when WP# is high). The reset command during the program/erase operation will result in the content of the selected locations(perform programming/erasing) might be partially programmed/erased.

If the Flash memory has already been set to reset stage with reset command, the additional new reset command is invalid.

Figure 21. AC waveforms for Reset Operation

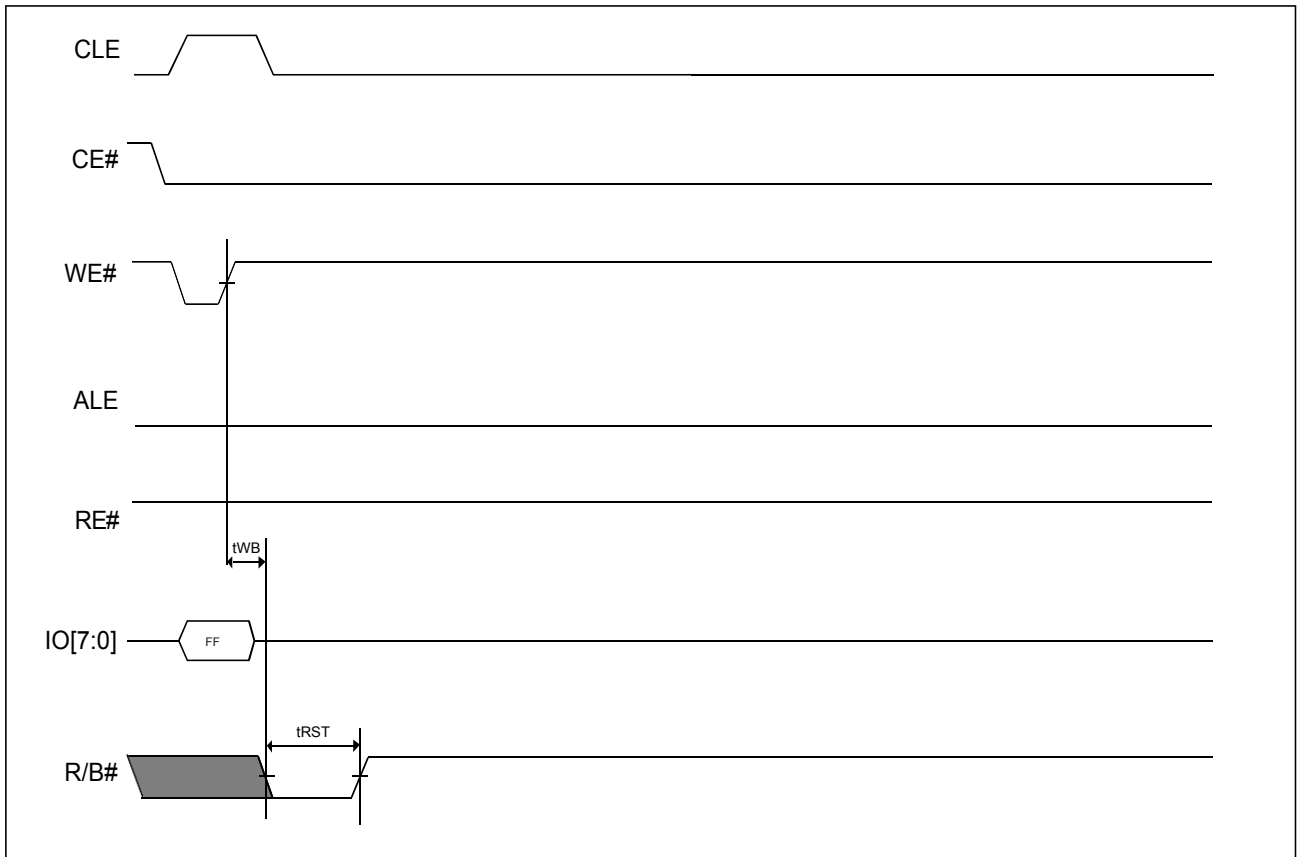

## 6-12. Parameter Page Read (ONFI)

The NAND Flash device support ONFI Parameter Page Read and the parameter can be read out by sending the command of ECh and giving the address 00h. The NAND device information may refer to the table of parameter page(ONFI), there are three copies of 256-byte data and additional redundant parameter pages.

Once sending the ECh command, the NAND device will remain in the Parameter Page Read mode until next valid command is sent.

The Random Data Out command set (05h-E0h) can be used to change the parameter location for the specific parameter data random read out.

The Status Read command (70h) can be used to check the completion with a following read command (00h) to enable the data out.

Figure 22. AC waveforms for Parameter Page Read (ONFI) Operation

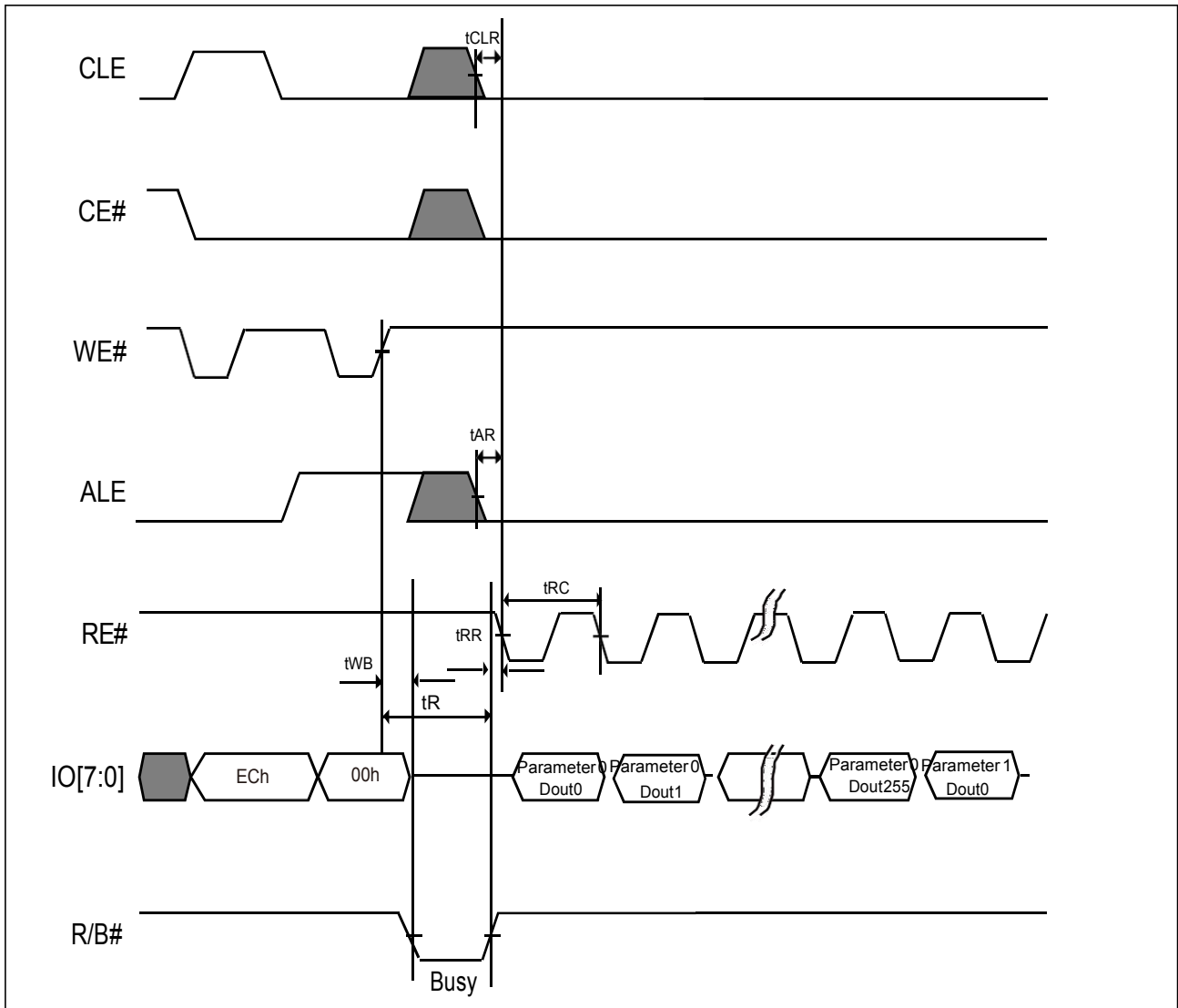
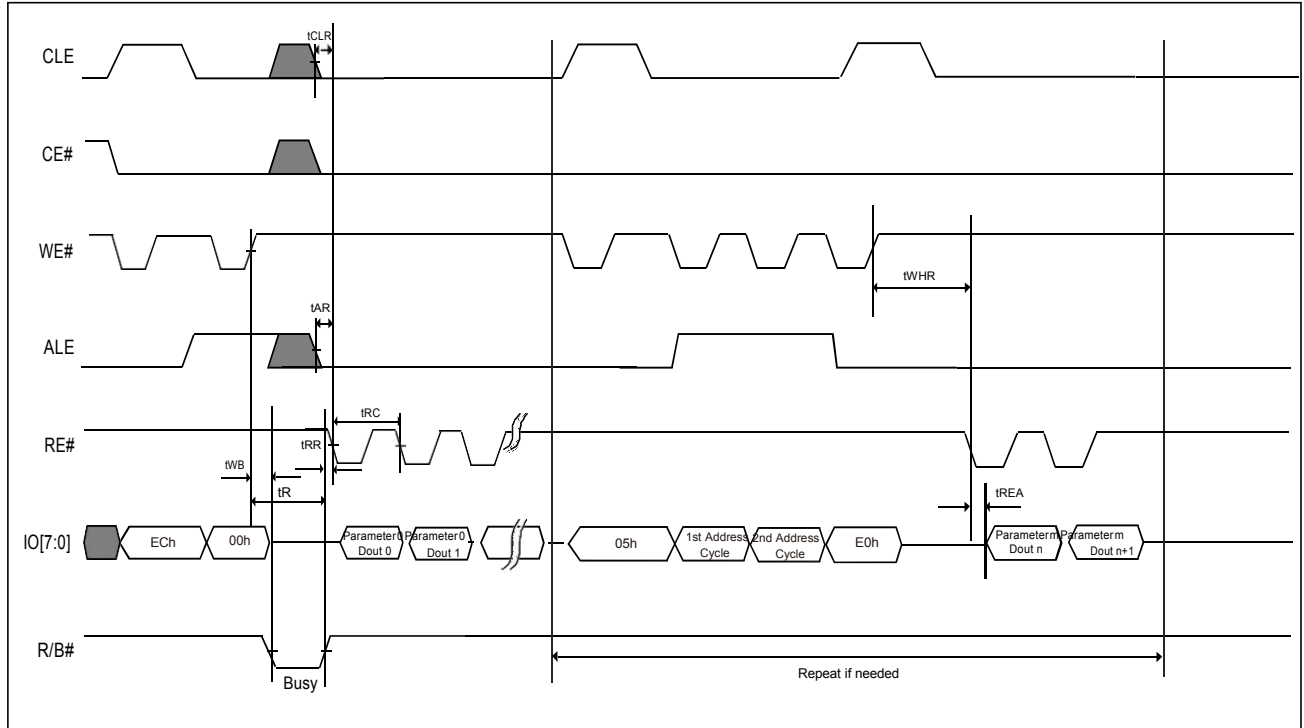

Figure 23. AC Waveforms for Parameter Page Read (ONFI) Random Operation (For 05h-E0h)



**Table 7. Parameter Page (ONFI)**

Revision Information and Features Block		
Byte#	Description	Data
0-3	Parameter Page Signature	4Fh, 4Eh, 46h, 49h
4-5	Revision Number	02h, 00h
6-7	Features Supported	10h, 00h
8-9	Optional Commands Supported	37h, 00h
10-31	Reserved	00h
Manufacturer Information Block		
Byte#	Description	Data
32-43	Device Manufacturer (12 ASCII characters)	4Dh,41h,43h,52h,4Fh,4Eh,49h,58h,20h,20h,20h,20h
44-63	Device Model (20 ASCII Characters)	MX30LF1G18AC 4Dh,58h,33h,30h,4Ch,46h,31h,47h,31h,38h,41h,43h,20h,20h,20h,20h,20h,20h,20h,20h,
64	JEDEC Manufacturer ID	C2h
65-66	Date Code	00h, 00h
67-79	Reserved	00h

Memory Organization Block		
Byte#	Description	Data
80-83	Number of Data Bytes per Page	2048-byte 00h,08h,00h,00h
84-85	Number of Spare Bytes per Page	64-byte 40h,00h
86-89	Number of Data Bytes per Partial Page	512-byte 00h,02h,00h,00h
90-91	Number of Spare Bytes per Partial Page	16-byte 10h,00h
92-95	Number of Pages per Block	40h,00h,00h,00h
96-99	Number of Blocks per Logical Unit	00h,04h,00h,00h
100	Number of Logical Units (LUNs)	01h
101	Number of Address Cycles	22h
102	Number of Bits per Cell	01h
103-104	Bad Blocks Maximum per LUN	14h,00h
105-106	Block endurance	01h, 05h
107	Guarantee Valid Blocks at Beginning of Target	01h
108-109	Block endurance for guaranteed valid blocks	01h, 03h
110	Number of Programs per Page	04h
111	Partrial Programming Attributes	00h
112	Number of Bits ECC Correctability	04h
113	Number of Interleaved Address Bits	00h
114	Interleaved Operation Attributes	00h
115-127	Reserved	00h

<b>Electrical Parameters Block</b>			
<b>Byte#</b>	<b>Description</b>		<b>Data</b>
<b>128</b>	I/O Pin Capacitance		0Ah
<b>129-130</b>	Timing Mode Support		3Fh,00h
<b>131-132</b>	Program Cache Timing Mode Support		3Fh,00h
<b>133-134</b>	tPROG Maximum Page Program Time (uS)	600us	58h,02h
<b>135-136</b>	tBERS(tERASE) Maximum Block Erase Time (uS)	3,500us	ACh,0Dh
<b>137-138</b>	tR Maximum Page Read Time (uS)	25us	19h,00h
<b>139-140</b>	tCCS Minimum Change Column Setup Time (ns)	60ns	3Ch,00h
<b>141-163</b>	Reserved		00h
<b>Vendor Blocks</b>			
<b>Byte#</b>	<b>Description</b>		<b>Data</b>
<b>164-165</b>	Vendor Specific Revision Number		00h
<b>166-253</b>	Vendor Specific		00h
<b>254-255</b>	Integrity CRC		Set at Test <b>(Note)</b>
<b>Redundant Parameter Pages</b>			
<b>Byte#</b>	<b>Description</b>		<b>Data</b>
<b>256-511</b>	Value of Bytes 0-255		
<b>512-767</b>	Value of Bytes 0-255		
<b>768+</b>	Additional Redundant Parameter Pages		

**Note:** The Integrity CRC (Cycling Redundancy Check) field is used to verify that the contents of the parameters page were transferred correctly to the host. Please refer to ONFI 1.0 specifications for details.

The CRC shall be calculated using the following 16-bit generator polynomial:

$$G(X) = X_{16} + X_{15} + X_2 + 1$$

### 6-13. Unique ID Read (ONFI)

The unique ID is 32-byte and with 16 copies for back-up purpose. After writing the Unique ID read command (EDh) and following the one address byte (00h), the host may read out the unique ID data. The host need to XOR the 1<sup>st</sup> 16-byte unique data and the 2<sup>nd</sup> 16-byte complement data to get the result, if the result is FFh, the unique ID data is correct; otherwise, host need to repeat the XOR with the next copy of Unique ID data.

Once sending the EDh command, the NAND device will remain in the Unique ID read mode until next valid command is sent.

To change the data output location, it is recommended to use the Random Data Out command set (05h-E0h).

The Status Read command (70h) can be used to check the completion. To continue the read operation, a following read command (00h) to re-enable the data out is necessary.

**Figure 24. AC waveforms for Unique ID Read Operation**

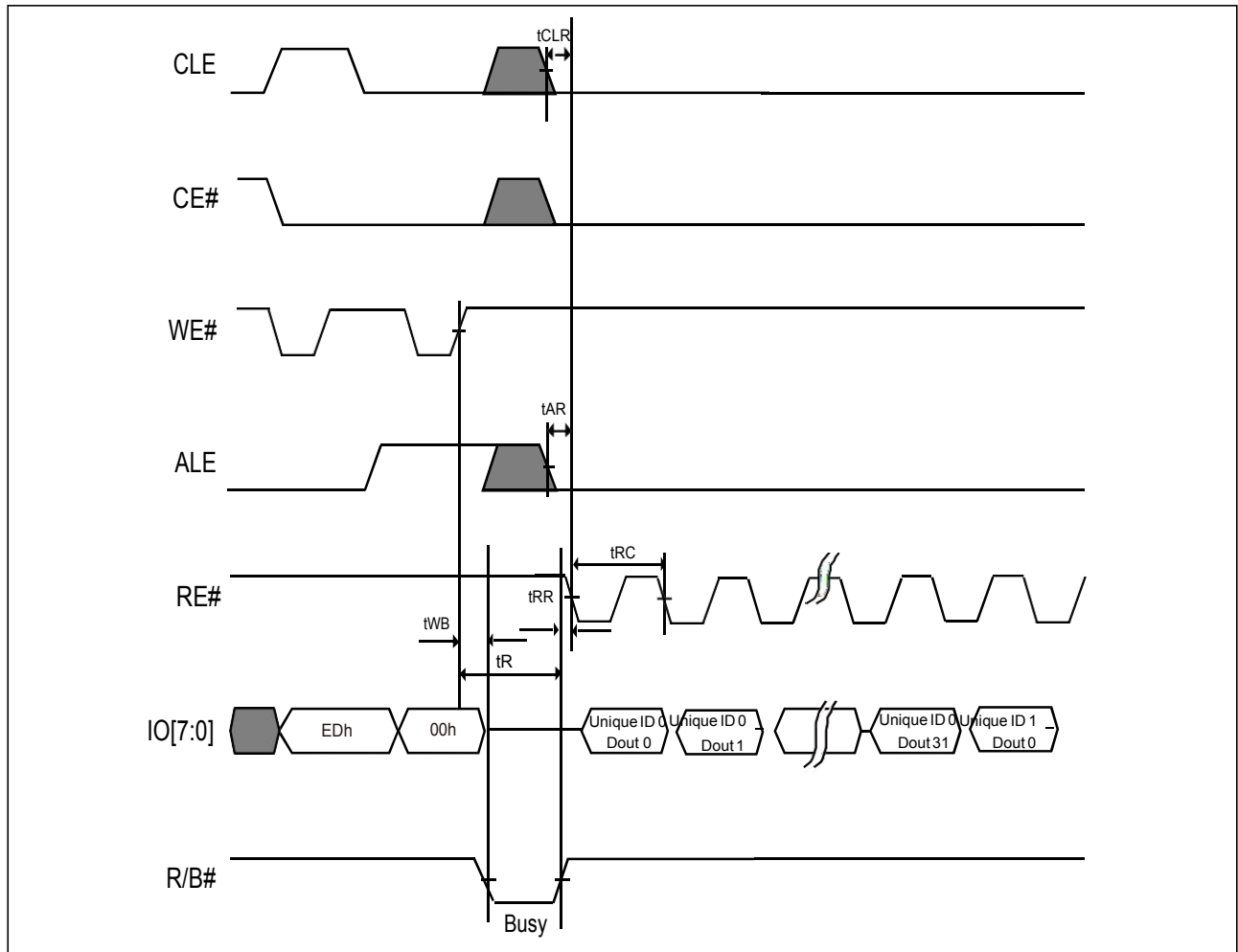
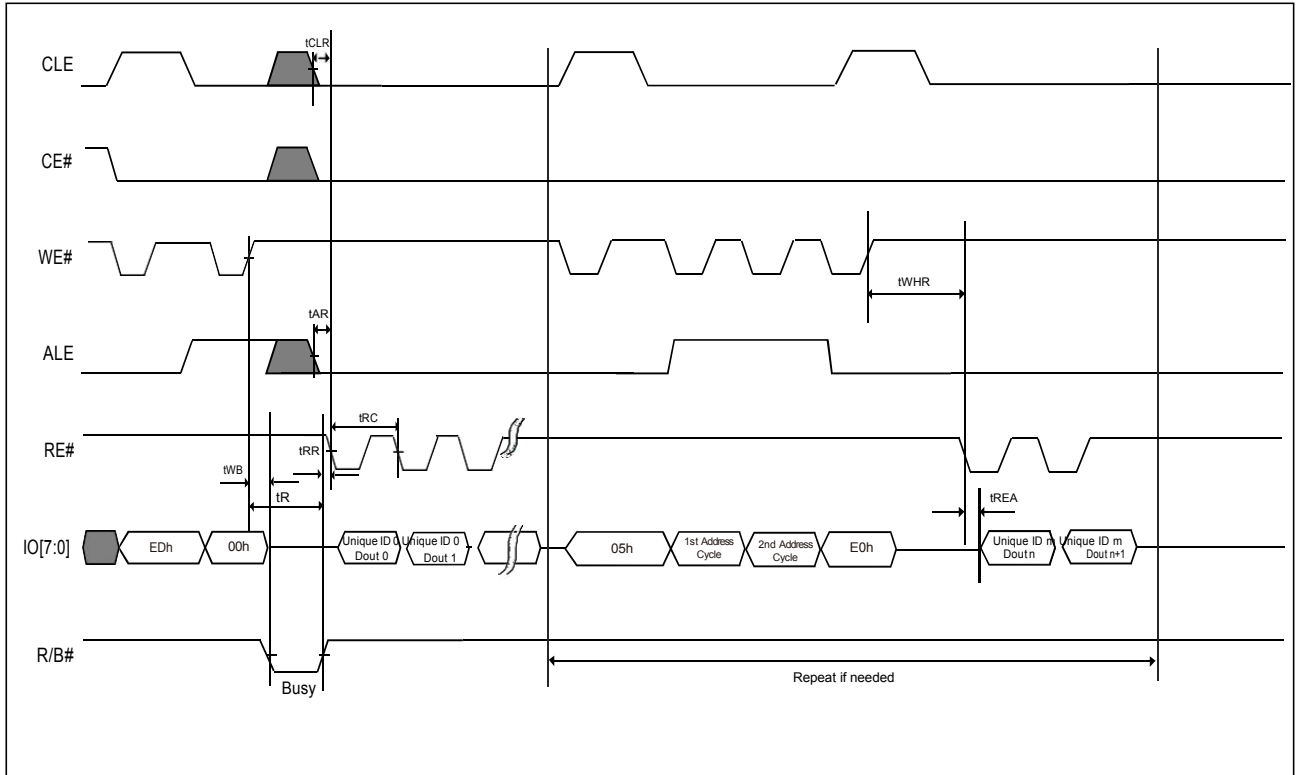

Figure 25. AC waveforms for Unique ID Read Operation (For 05h-E0h)



## 6-14. Feature Set Operation (ONFI)

The Feature Set operation is to change the default power-on feature sets by using the Set Feature and Get Feature command and writing the specific parameter data (P1-P4) on the specific feature addresses. The NAND device may remain the current feature set until next power cycle since the feature set data is volatile. However, the reset command (FFh) can not reset the current feature set.

**Table 8-1. Definition of Feature Address**

Feature Address	Description
00h-8Fh, 91h-FFh,	Reserved
90h	Array Operation Mode
A0h	Block Protection Operation

**Table 8-2. Sub-Feature Parameter Table of Feature Address - 90h (Array Operation Mode)**

Sub Feature Parameter	Definition	IO7	IO6	IO5	IO4	IO3	IO2	IO1	IO0	Values	Notes
P1	Array Operation Mode	Normal		Reserved (0)				0	0	0000 0000b	1
		OTP Operation		Reserved (0)		0	0	1	0000 0001b		
		OTP Protection		Reserved (0)		0	1	1	0000 0011b		
P2		Reserved (0)							0000 0000b		
P3		Reserved (0)							0000 0000b		
P4		Reserved (0)							0000 0000b		

**Note 1.** The value is clear to 00h at power cycle.

**Table 8-3. Sub-Feature Parameter Table of Feature Address - A0h (Block Protection Operation) (note 1)**

Sub Feature Parameter	Definition	IO7	IO6	IO5	IO4	IO3	IO2	IO1	IO0	Values	Notes
P1	Block Protection Operation	0	0	1	1	1	0	0	0	38h	note 2
	Protection Bit Setting	0	0	BP2	BP1	BP0	Invert	Complementary	SP	note 3	note 4
P2		Reserved (0)									
P3		Reserved (0)									
P4		Reserved (0)									

**Notes:**

1. If the PT pin is not connected to high, this sub-feature address A0h command is not valid.
2. The value is returned to 38h at power cycle.
3. The value is defined in the Table 9. Definition of Protection Bits.
4. The SP stands for Solid-Protection. Once the SPbit sets as 1, the rest of protection bits cannot be changed during the current power cycle.



### 6-14-1. Set Feature (ONFI)

The Set Feature command is to change the power-on default feature set. After sending the Set Feature command (EFh) and following specific feature and then input the P1-P4 parameter data to change the default power-on feature set. Once sending the EFh command, the NAND device will remain in the Set Feature mode until next valid command is sent.

The Status Read command (70h) may check the completion of the Set Feature.

**Figure 26. AC Waveforms for Set Feature (ONFI) Operation**

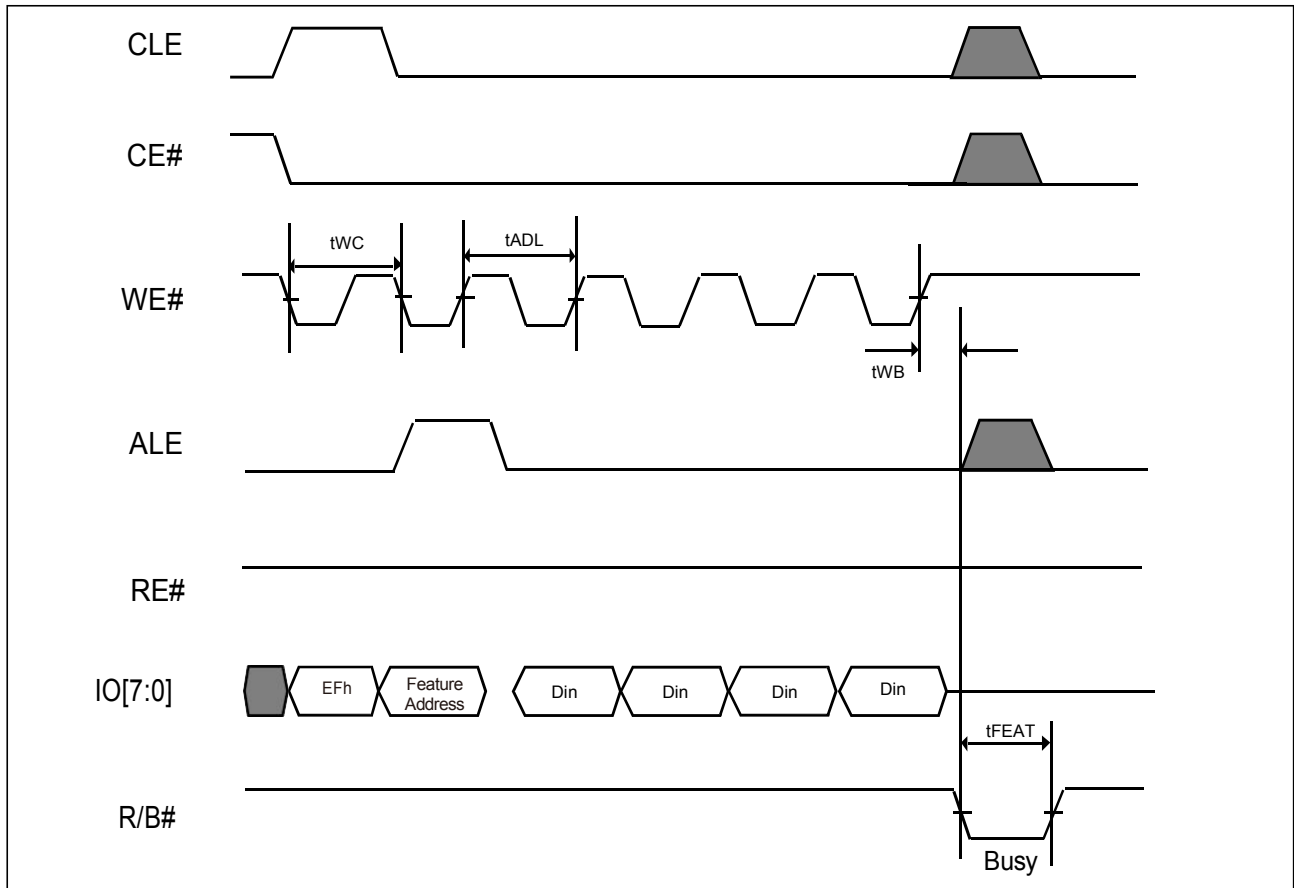

### 6-14-2. Get Feature (ONFI)

The Get Feature command is to read sub-feature parameter. After sending the Get Feature command (EEh) and following specific feature, the host may read out the P1-P4 sub- feature parameter data. Once sending the EEh command, the NAND device will remain in the Get Feature mode until next valid command is sent.

The Status Read command (70h) can be used to check the completion. To continue the read operation, a following read command (00h) to re-enable the data out is necessary.

Please refer to the following waveform of **Get Feature Operation** for details.

**Figure 27. AC Waveforms for Get Feature (ONFI) Operation**

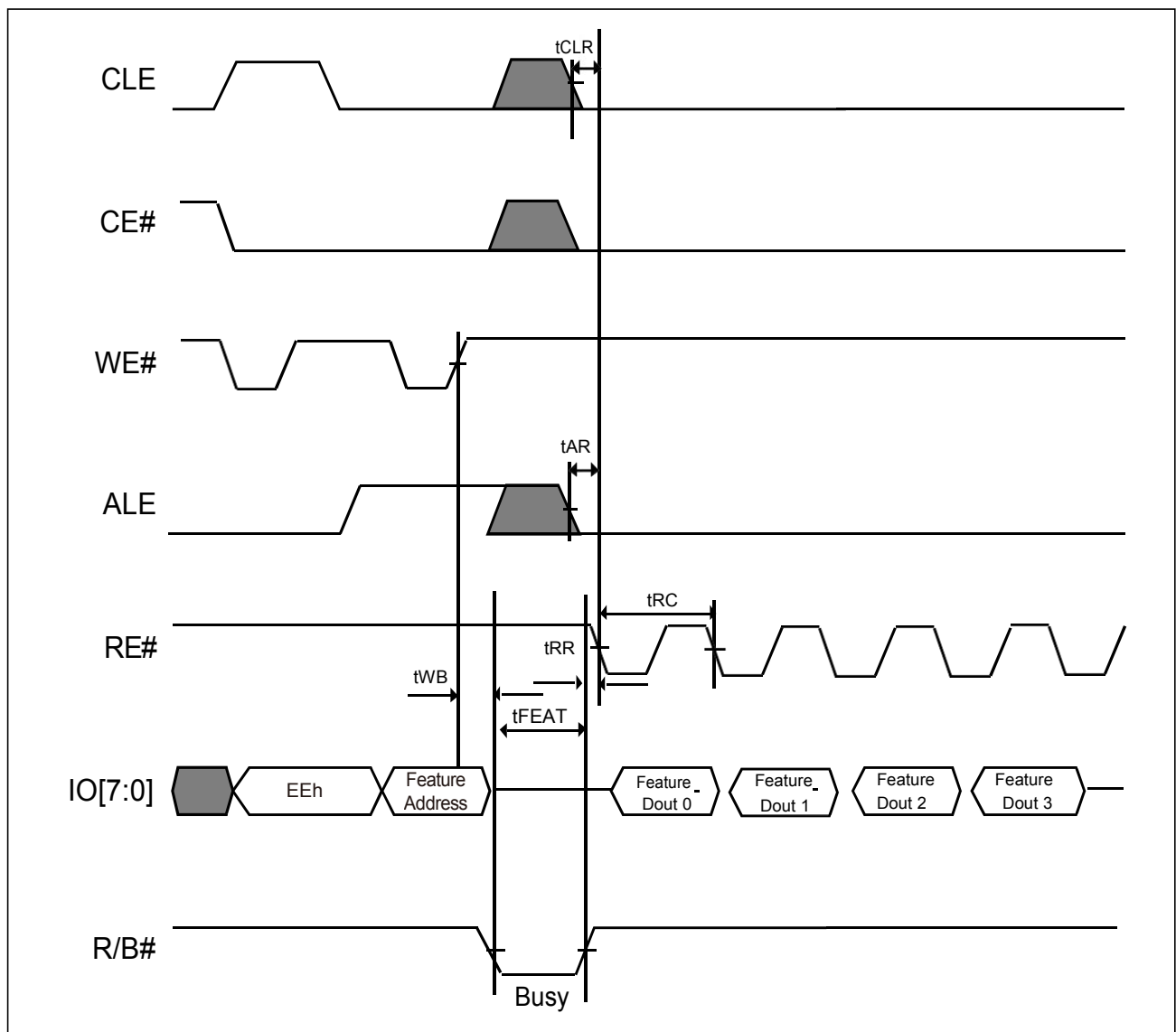

### 6-14-3. Secure OTP (One-Time-Programmable) Feature

There is an OTP area which has thirty full pages (30 x 2,112-byte) guarantee to be good for system device serial number storage or other fixed code storage. The OTP area is a non-erasable and one-time-programmable area, which is default to “1” and allows whole page or partial page program to be “0”, once the OTP protection mode is set, the OTP area becomes read-only and cannot be programmed again.

The OTP operation is operated by the Set Feature/ Get Feature operation to access the OTP operation mode and OTP protection mode.

To check the NAND device is ready or busy in the OTP operation mode, either checking the R/B# or writing the Status Read command (70h) may collect the status.

To exit the OTP operation or protect mode, it can be done by writing 00h to P1 at feature address 90h.

#### OTP Read/Program Operation

To enter the OTP operation mode, it is by using the Set Feature command (EFh) and followed by the feature address (90h) and then input the 01h to P1 and 00h to P2-P4 of sub-Feature Parameter data( please refer to **Table 8-2. Sub-Feature Parameter Table of Feature Address - 90h (Array Operation Mode)** and **Table 8-3. Sub-Feature Parameter Table of Feature Address - A0h (Block Protection Operation) (note 1)**). After enter the OTP operation mode, the normal Read command (00h-30h) or Page program( 80h-10h) command can be used to read the OTP area or program it. The address of OTP is located on the 02h-1Fh of page address.

Besides the normal Read command, the Random Data Output command (05h-E0h) can be used for read OTP data. However, the Cache Read command is not supported in the OTP area.

Besides the normal page program command, the Random Data Input command (85h) allows multi-data load in non-sequential address. After data load is completed, a program confirm command (10h) is issued to start the page program operation. The number of partial-page OTP program is 8 per each OTP page.

Figure 28. AC Waveforms for OTP Data Read

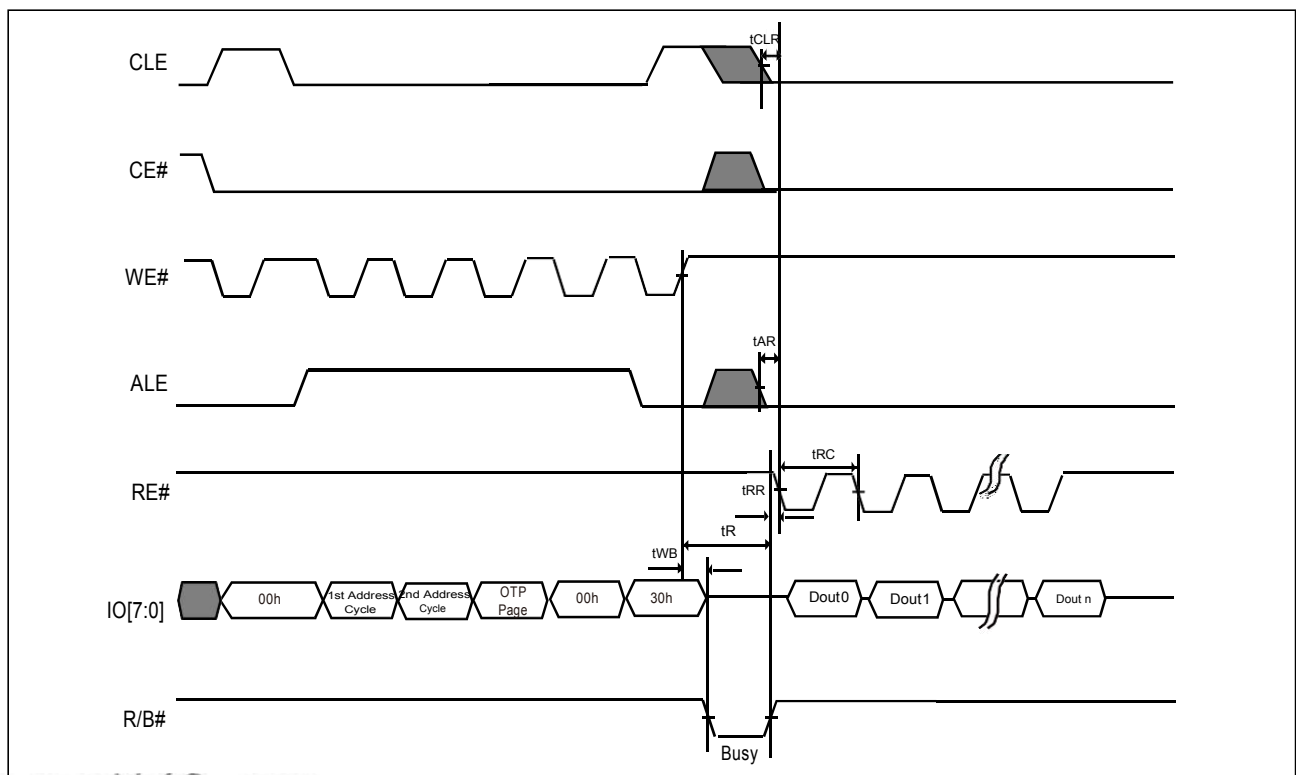

Figure 29. AC Waveforms for OTP Data Read with Random Data Output

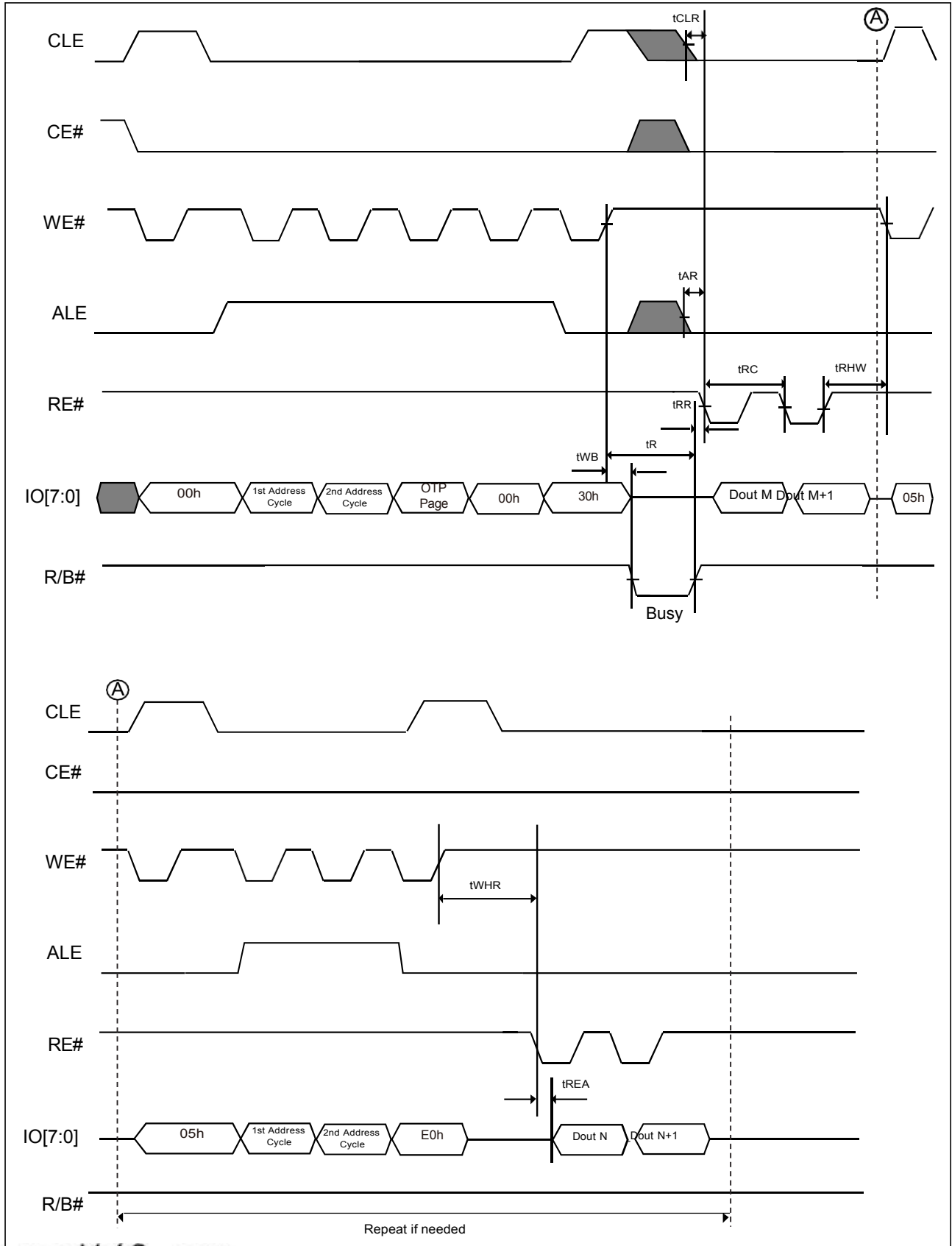

Figure 30. AC Waveforms for OTP Data Program

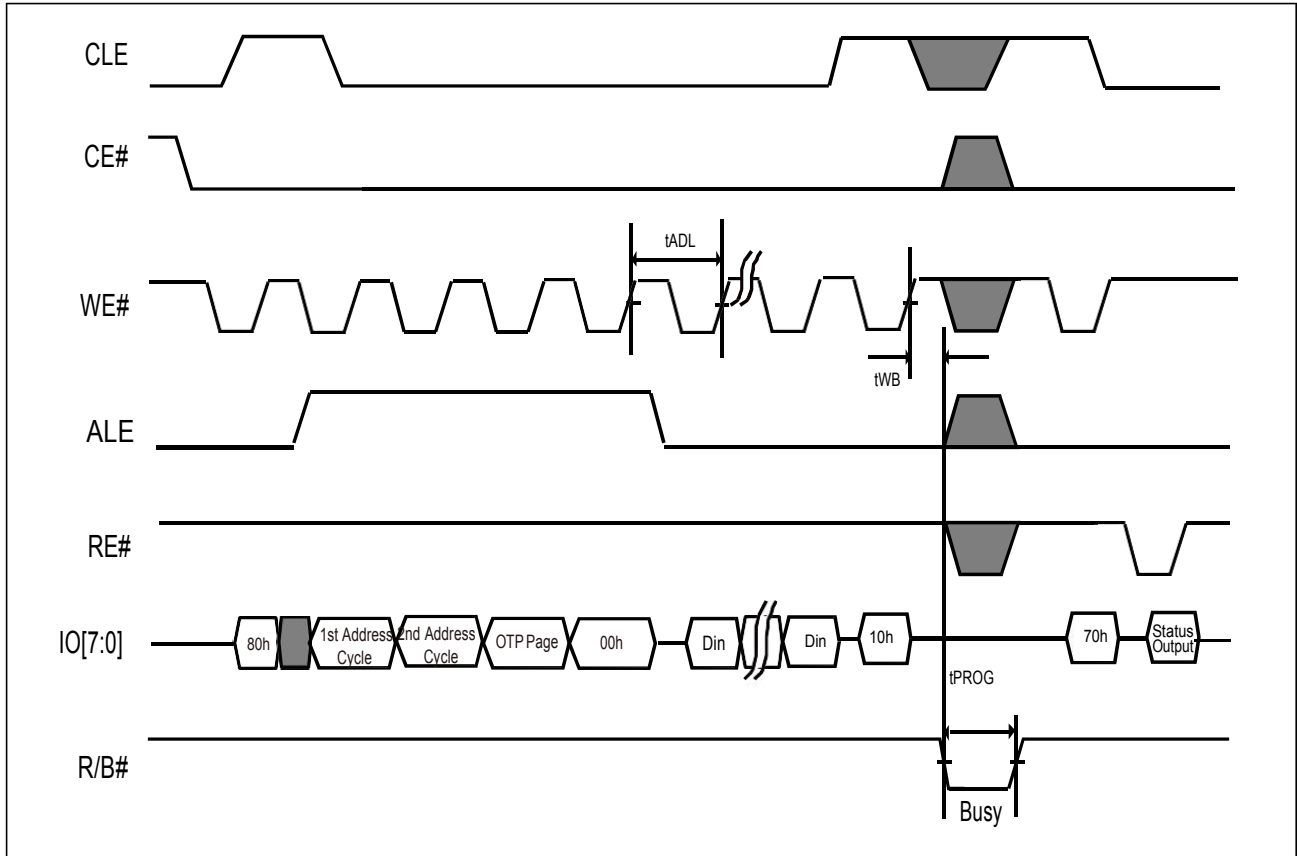
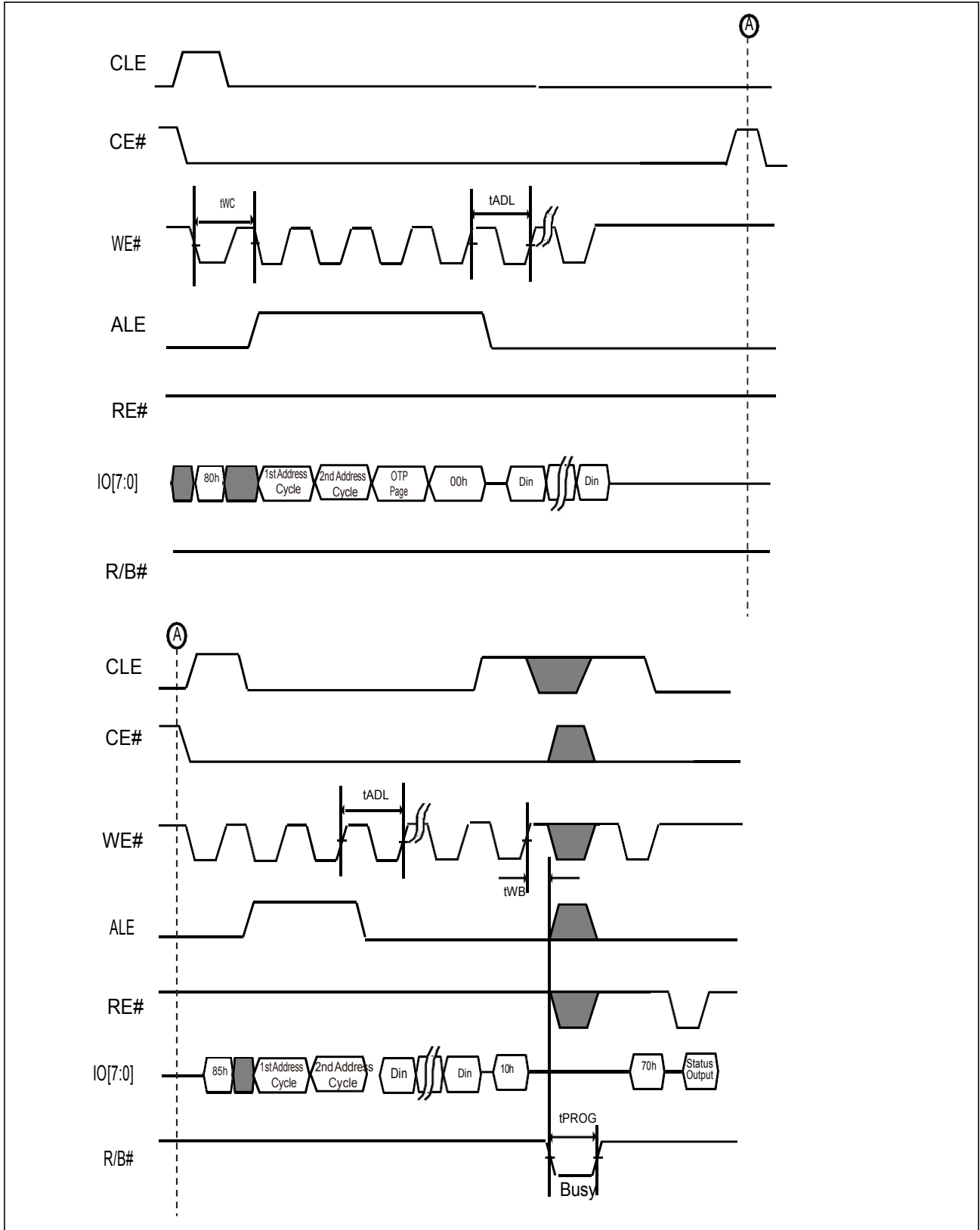

Figure 31. AC Waveforms for OTP Data Program with Random Data Input



### OTP Protection Operation

To prevent the further OTP data to be changed, the OTP protection mode operation is necessary. To enter the OTP protection mode, it can be done by using the Set Feature command (EFh) and followed by the feature address (90h) and then input the 03h to P1 and 00h to P2-P4 of sub-Feature Parameter data (please refer to the **Table 8-2. Sub-Feature Parameter Table of Feature Address - 90h (Array Operation Mode)** and **Table 8-3. Sub-Feature Parameter Table of Feature Address - A0h (Block Protection Operation) (note 1)**). And then the normal page program command (80h-10h) with the address 00h before the 10h command is required.

The OTP Protection mode is operated by the whole OTP area instead of individual OTP page. Once the OTP protection mode is set, the OTP area cannot be programmed or unprotected again.

**Figure 32. AC Waveforms for OTP Protection Operation**

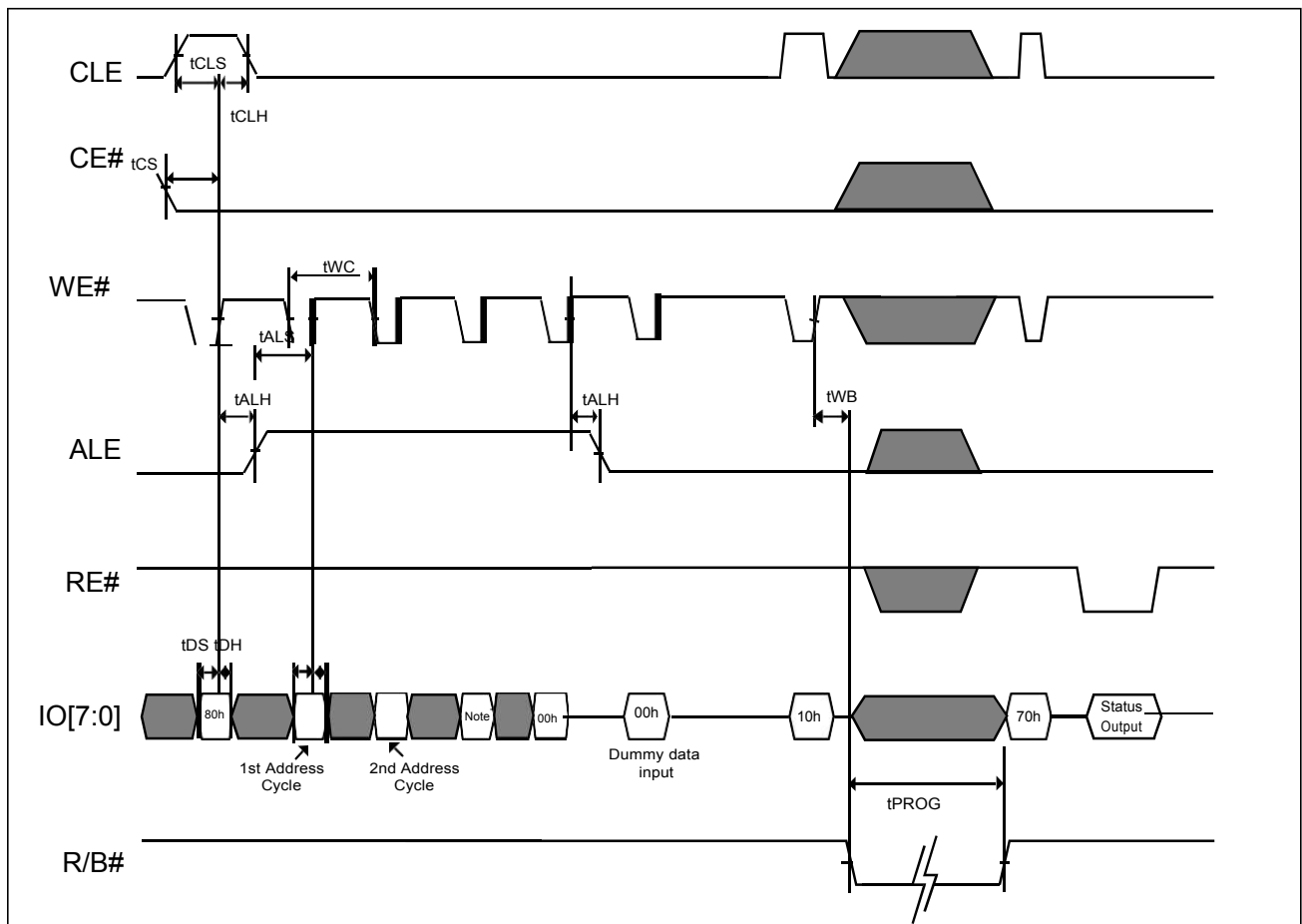

**Note:** This address cycle can be any value since the OTP protection protects the entire OTP area instead of individual OTP page.

#### 6-14-4. Block Protection

The block protect operation can protect the whole chip or selected blocks from erasing or programming. Through the PT pin at power-on stage, it decides the block protection operation is enabled or disabled. At power-on, if the PT pin is connected to high, the block protection operation is enabled, all the blocks are default to be protected from programming/erasing even the WP# is disabled. If the PT pin is low, block protection operation is disabled. Please refer to the **Figure 33. PT Pin and Block Protection Mode Operation**.

When program or erase attempt at a protected block is happened, the R/B# keeps low for the time of tPBSY, and the Status Read command (70h) may get the 60h result.

There are Temporary Protection/un-Protection and Solid Protection features as below description.

##### Temporary Protection/un-Protection

At power-on, if the PT pin is connected to high, all the blocks are default to be protected for the BPx protection bits are all “1”. The Set feature command with feature address A0h followed by the destined protection bits data is necessary to un-protect those selected blocks before those selected blocks to be updated. The WP# pin needs to connect to high before writing the Set Feature command for the block protection operation. After the selected blocks are un-protected, those un-protected blocks can be protected again by Block Protection procedure if required.

##### Solid Protection

The “solid-protection” feature can be set by writing the Set Feature command with address A0h and the “SP” solid-protection bit as “1”, after that, the selected block is solid-protected and cannot be up-protected until next power cycle.

**Table 9. Definition of Protection Bits**

BP2	BP1	BP0	Invert	Complementary	Protection Area
0	0	0	x	x	all unlocked
0	0	1	0	0	upper 1/64 locked
0	1	0	0	0	upper 1/32 locked
0	1	1	0	0	upper 1/16 locked
1	0	0	0	0	upper 1/8 locked
1	0	1	0	0	upper 1/4 locked
1	1	0	0	0	upper 1/2 locked
1	1	1	x	x	all locked (default)
0	0	1	1	0	lower 1/64 locked
0	1	0	1	0	lower 1/32 locked
0	1	1	1	0	lower 1/16 locked
1	0	0	1	0	lower 1/8 locked
1	0	1	1	0	lower 1/4 locked
1	1	0	1	0	lower 1/2 locked
0	0	1	0	1	lower 63/64 locked
0	1	0	0	1	lower 31/32 locked
0	1	1	0	1	lower 15/16 locked
1	0	0	0	1	lower 7/8 locked
1	0	1	0	1	lower 3/4 locked
1	1	0	0	1	block 0
0	0	1	1	1	upper 63/64 locked
0	1	0	1	1	upper 31/32 locked
0	1	1	1	1	upper 15/16 locked
1	0	0	1	1	upper 7/8 locked
1	0	1	1	1	upper 3/4 locked
1	1	0	1	1	block0



Figure 33. PT Pin and Block Protection Mode Operation

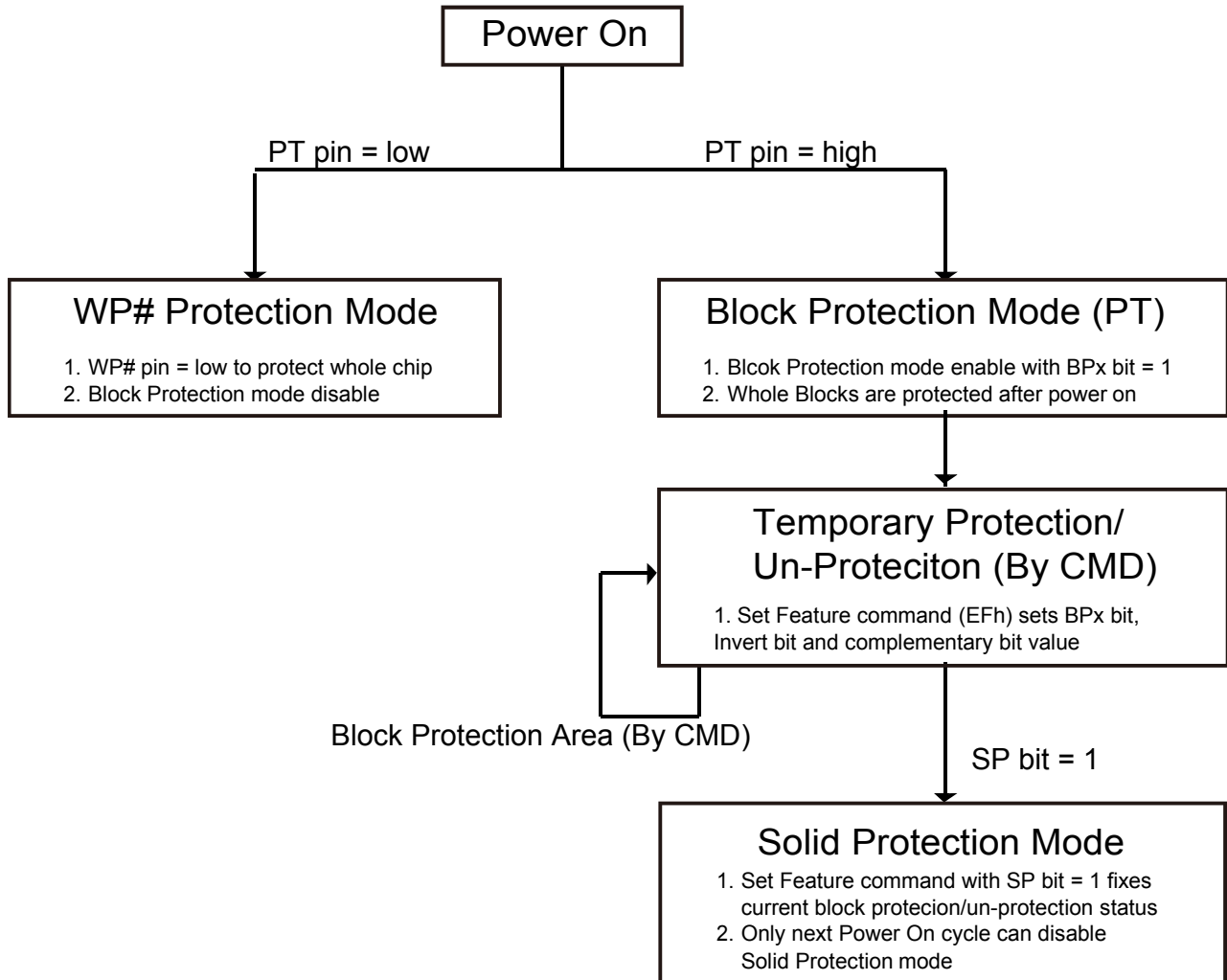

## 7. PARAMETERS

### 7-1. ABSOLUTE MAXIMUM RATINGS

Temperature under Bias	-50°C to +125°C
Storage temperature	-65°C to +150°C
All input voltages with respect to ground (Note 2)	-0.6V to 4.6V
VCC supply voltage with respect to ground (Note 2)	-0.6V to 4.6V
ESD protection	>2000V

**Notes:**

1. The reliability of device may be impaired by exposing to extreme maximum rating conditions for long range of time.
2. Permanent damage may be caused by the stresses higher than the "Absolute Maximum Ratings" listed.
3. During voltage transitions, all pins may overshoot Vss to -2.0V and Vcc to +2.0V for periods up to 20ns, as shown in **Figure 34. Maximum Negative Overshoot Waveform** and **Figure 35. Maximum Positive Overshoot Waveform**.

**Figure 34. Maximum Negative Overshoot Waveform** **Figure 35. Maximum Positive Overshoot Waveform**

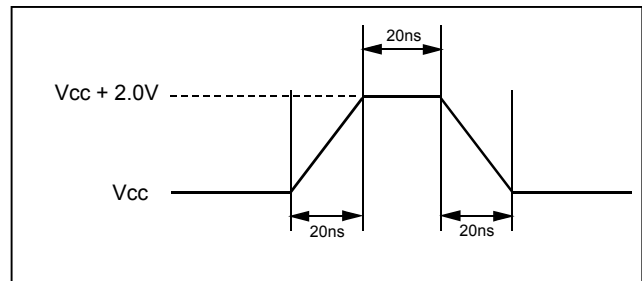
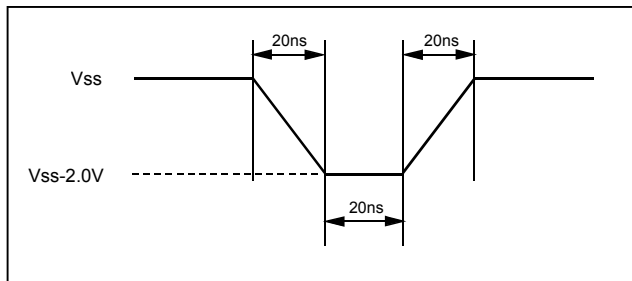

**Table 10. Operating Range**

Temperature	VCC	Tolerance
-40°C to +85°C	+3.3V	2.7 - 3.6V

**Table 11. DC Characteristics**

Symbol	Parameter	Test Conditions	Min.	Typical	Max.	Unit	Notes
VIL	Input low level		-0.3		0.2VCC	V	
VIH	Input high level		0.8VCC		VCC + 0.3	V	
VOL	Output low voltage	IOL= 2.1mA, VCC= VCC Min.			0.2	V	
VOH	Output high voltage	IOH= -400uA, VCC= VCC Min.	VCC-0.2			V	
ISB1	VCC standby current (CMOS)	CE# = VCC -0.2V, WP# = 0/VCC		10	50	uA	
ISB2	VCC standby current (TTL)	CE# = VIH Min., WP# = 0/VCC			1	mA	
ICC0	Power on current (Including POR current)				50	mA	
ICC1	VCC active current (Sequential Read)	tRC Min., CE# = VIL, IOU= 0mA		15	30	mA	
ICC2	VCC active current (Program)			15	30	mA	
ICC3	VCC active current (Erase)			15	30	mA	
ILI	Input leakage current	VIN= 0 to VCC Max.			+/- 10	uA	
ILO	Output leakage current	VOU= 0 to VCC Max.			+/- 10	uA	
ILO (R/B#)	Output current of R/B# pin	VOL=0.4V	8	10		mA	

**Table 12. Capacitance**

TA = +25°C, F = 1 MHz

Symbol	Parameter	Typ.	Max.	Units	Conditions
CIN	Input capacitance		10	pF	VIN = 0 V
COUT	Output capacitance		10	pF	VOUT = 0 V

**Table 13. AC Testing Conditions**

Testing Conditions	Value	Unit
Input pulse level	0 to VCC	V
Output load capacitance	1TTL+CL(50)	pF
Input rise and fall time	5	ns
Input timing measurement reference levels	VCC/2	V
Output timing measurement reference levels	VCC/2	V

**Table 14. Program and Erase Characteristics**

Symbol	Parameter	Min.	Typ.	Max.	Unit	Note
tPROG	Page programming time		300	600	us	
tCBSY (Program)	Dummy busy time for cache program		5	600	us	
tRCBSY (Read)	Dummy busy time for cache read		3.5	25	us	
tDBSY	The busy time for two-plane program/erase operation		0.5	1	us	
tFEAT	The busy time for Set Feature/ Get Feature			1	us	
tOBSY	The busy time for OTP program at OTP protection mode			30	us	
tPBSY	The busy time for program/erase at protected blocks			3	us	
NOP	Number of partial program cycles in same page			4	cycles	
tERASE (Block)	Block erase time		1	3.5	ms	

**Table 15. AC Characteristics**

Symbol	Parameter	Min.	Typical	Max.	Unit	Note
tCLS	CLE setup time	10			ns	1
tCLH	CLE hold time	5			ns	1
tCS	CE# setup time	15			ns	1
tCH	CE# hold time	5			ns	1
tWP	Write pulse width	10			ns	1
tALS	ALE setup time	10			ns	1
tALH	ALE hold time	5			ns	1
tDS	Data setup time	7			ns	1
tDH	Data hold time	5			ns	1
tWC	Write cycle time	20			ns	1, 2
tWH	WE# high hold time	7			ns	1
tADL	Last address latched to data loading timeduring program operations	70			ns	1
tWW	WP# transition to WE# high	100			ns	1
tRR	Ready to RE# falling edge	20			ns	1
tRP	Read pulse width	10			ns	1
tRC	Read cycle time	20			ns	1
tREA	RE# access time (serial data access)			16	ns	1
tCEA	CE# access time			25	ns	1
tRLOH	RE#-low to data hold time (EDO)	5			ns	
tOH	Data output hold time	15			ns	1
tRHZ	RE#-high to output-high impedance			60	ns	1
tCHZ	CE#-high to output-high impedance			50	ns	1
tCOH	CE# high to output hold time	15			ns	
tREH	RE# high hold time	7			ns	1
tIR	Output high impedance to RE# falling edge	0			ns	1
tRHW	RE# high to WE# low	60			ns	1
tWHR	WE# high to RE# low	60			ns	1
tR	The data transferring from array to buffer			25	us	1
tWB	WE# high to busy			100	ns	1
tCLR	CLE low to RE# low	10			ns	1
tAR	ALE low to RE# low	10			ns	1
tRST	Device reset time (Idle/ Read/ Program/ Erase)			5/5/10/500	us	1

*Note 1. ONFI Mode 5 compliant*

## 8. OPERATION MODES: LOGIC AND COMMAND TABLES

Address input, command input and data input/output are managed by the CLE, ALE, CE#, WE#, RE# and WP# signals, as shown in **Table 16. Logic Table** below.

Program, Erase, Read and Reset are four major operations modes controlled by command sets, please refer to **Table 17. HEX Command Table**.

**Table 16. Logic Table**

Mode	CE#	RE#	WE#	CLE	ALE	WP#
Address Input (Read Mode)	L	H	↑	L	H	X
Address Input (Write Mode)	L	H	↑	L	H	H
Command Input (Read Mode)	L	H	↑	H	L	X
Command Input (Write Mode)	L	H	↑	H	L	H
Data Input	L	H	↑	L	L	H
Data Output	L	↓	H	L	L	X
During Read (Busy)	X	H	H	L	L	X
During Programming (Busy)	X	X	X	X	X	H
During Erasing (Busy)	X	X	X	X	X	H
Program/Erase Inhibit	X	X	X	X	X	L
Stand-by	H	X	X	X	X	0V/VCC

**Notes:**

1. H = VIH; L = VIL; X = VIH or VIL
2. WP# should be biased to CMOS high or CMOS low for stand-by.

**Table 17. HEX Command Table**

	<b>First Cycle</b>	<b>Second Cycle</b>	<b>Acceptable While Busy</b>
<b>Read Mode</b>	00H	30H	
<b>Random Data Input</b>	85H	-	
<b>Random Data Output</b>	05H	E0H	
<b>Cache Read Random</b>	00H	31H	
<b>Cache Read Sequential</b>	31H	-	
<b>Cache Read End</b>	3FH	-	
<b>ID Read</b>	90H	-	
<b>Parameter Page Read (ONFI)</b>	ECH	-	
<b>Unique ID Read (ONFI)</b>	EDH	-	
<b>Set Feature (ONFI)</b>	EFH	-	
<b>Get Feature (ONFI)</b>	EEH	-	
<b>Reset</b>	FFH	-	V
<b>Page Program</b>	80H	10H	
<b>Cache Program</b>	80H	15H	
<b>Block Erase</b>	60H	D0H	
<b>Status Read</b>	70H	-	V
<b>Block Protection Status Read</b>	7AH	-	

**Caution:** None of the undefined command inputs can be accepted except for the command set in the above table.

## 8-1. R/B#: Termination for The Ready/Busy# Pin (R/B#)

The R/B# is an open-drain output pin and a pull-up resistor is necessary to add on the R/B# pin. The R/B# outputs the ready/busy status of read/program/ erase operation of the device. When the R/B# is at low, the device is busy for read or program or erase operation. When the R/B# is at high, the read/program/erase operation is finished.

### Rp Value Guidance

The rise time of the R/B# signal depends on the combination of Rp and capacitive loading of the R/B# circuit. It is approximately two times constants (Tc) between the 10% and 90% points on the R/B# waveform.

$$T_c = R \times C$$

Where R = Rp (Resistance of pull-up resistor), and C = CL (Total capacitive load)

The fall time of the R/B# signal majorly depends on the output impedance of the R/B# signal and the total load capacitance.

$$R_p (\text{Min.}) = \frac{V_{CC} (\text{Max.}) - V_{OL} (\text{Max.})}{I_{OL} + \Sigma I_L}$$

#### Notes:

1. Considering of the variation of device-by-device, the above data is for reference to decide the resistor value.
2. Rp maximum value depends on the maximum permissible limit of tr.
3. IL is the total sum of the input currents of all devices tied to the R/B pin.



Figure 36. R/B# Pin Timing Information

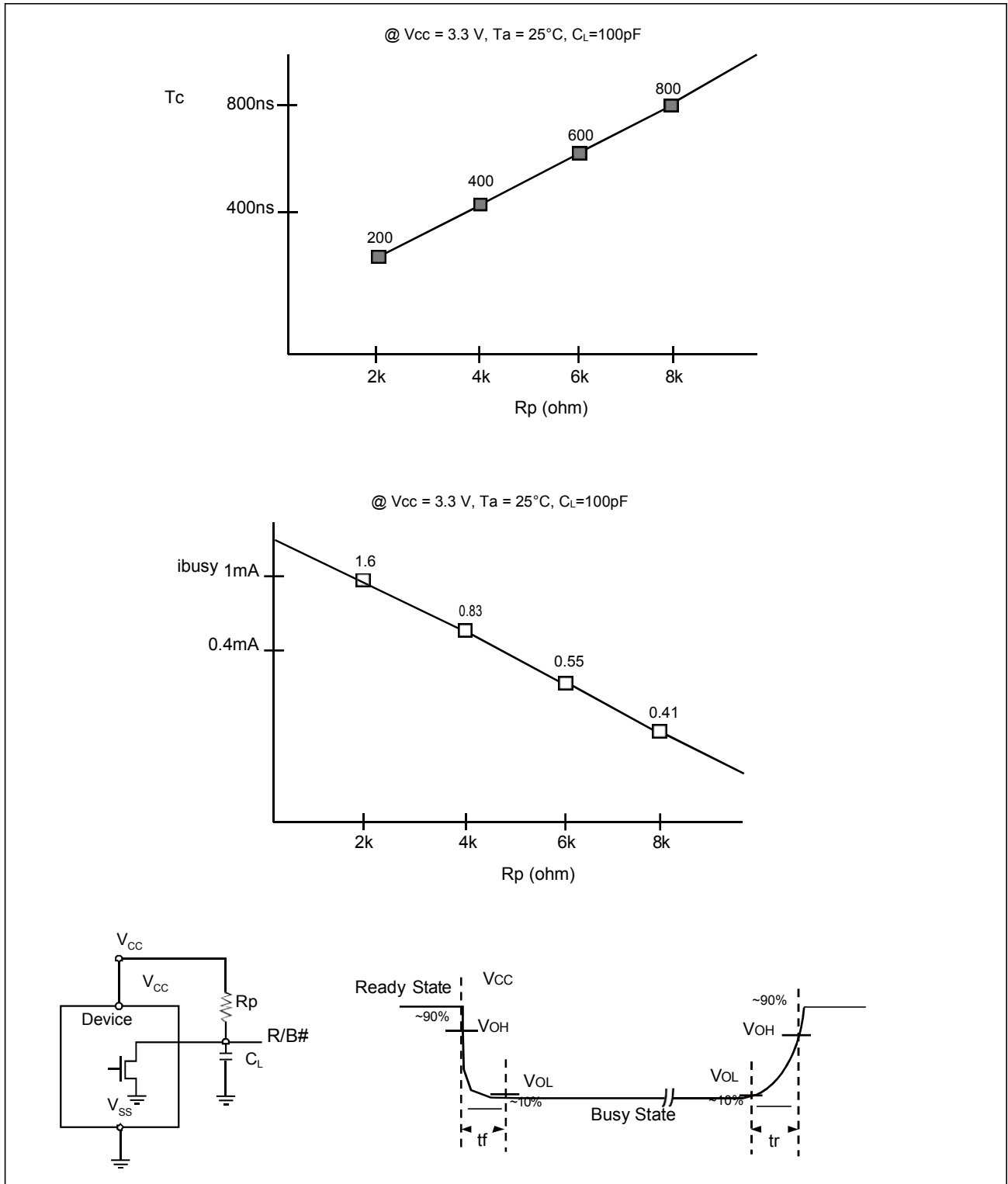

## 8-2. Power On/Off Sequence

After the Chip reaches the power on level ( $V_{th} = V_{cc \text{ min.}}$ ), the internal power on reset sequence will be triggered. During the internal power on reset period, no any external command is accepted. There are two ways to identify the termination of the internal power on reset sequence. Please refer to **Figure 37. Power On/Off Sequence**.

- R/B# pin
- Wait 1 ms

During the power on and power off sequence, it is recommended to keep the WP# = Low for internal data protection.

**Figure 37. Power On/Off Sequence**

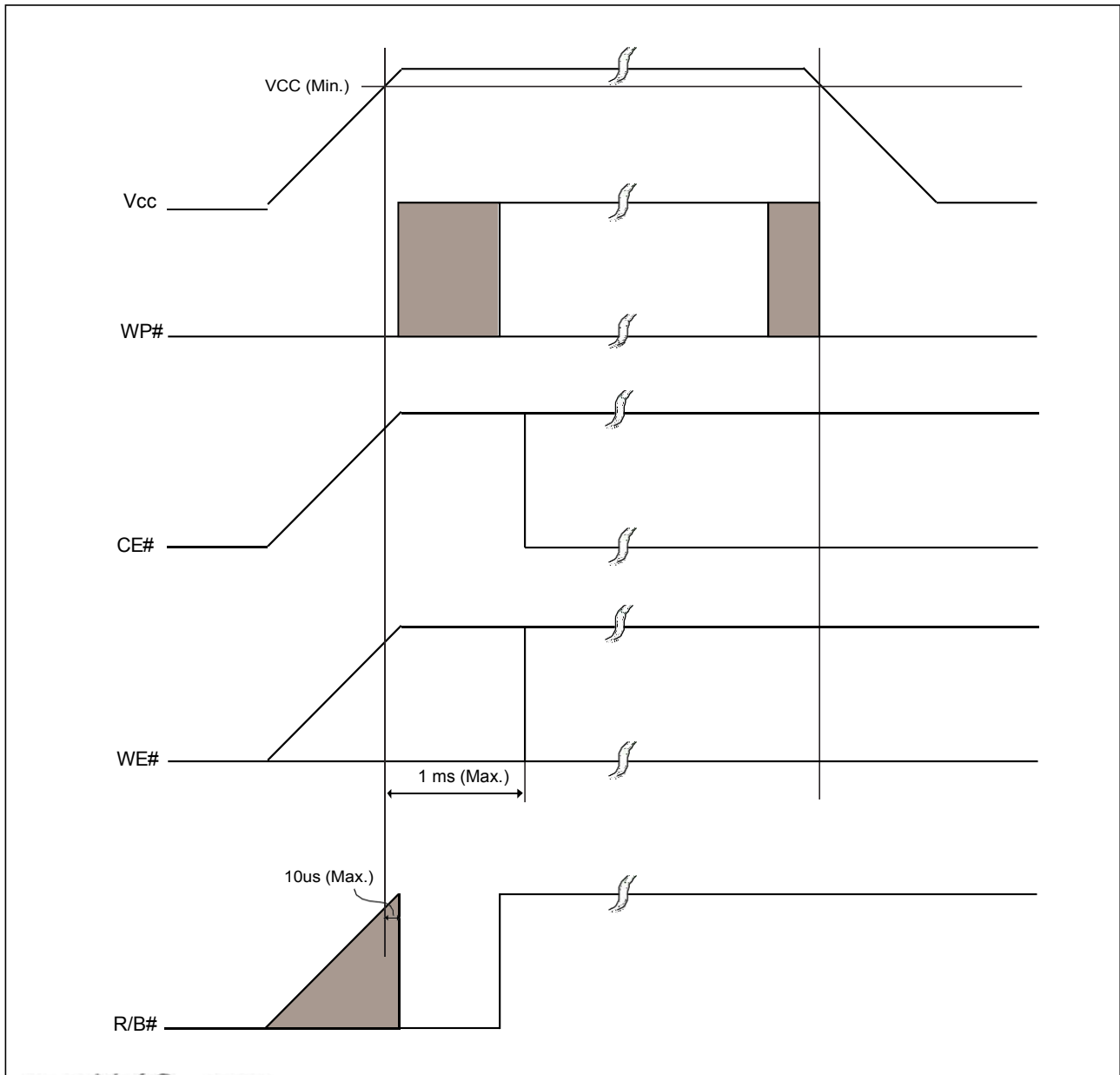

### 8-2-1. WP# Signal

WP# going Low can cause program and erase operations automatically reset.

The enabling & disabling of the both operations are as below:

Figure 38-1. Enable Programming of WP# Signal

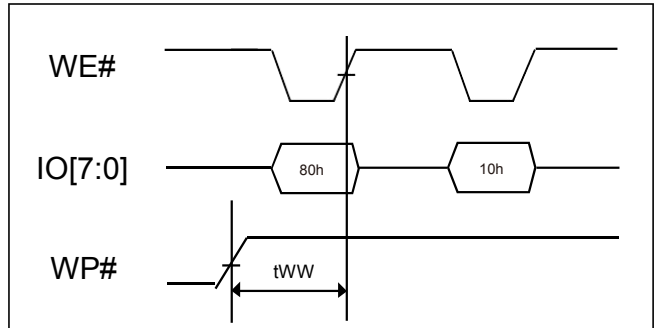

Figure 38-2. Disable Programming of WP# Signal

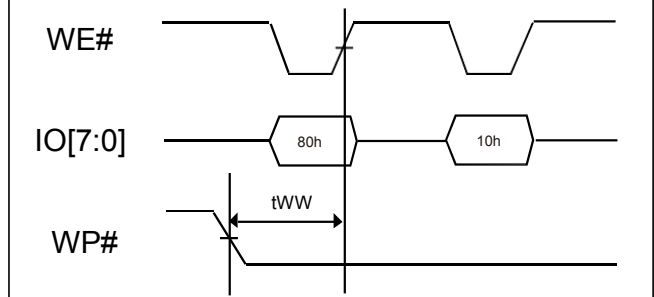

Figure 38-3. Enable Erasing of WP# Signal

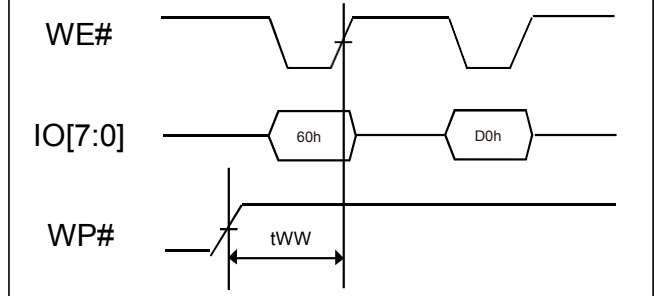
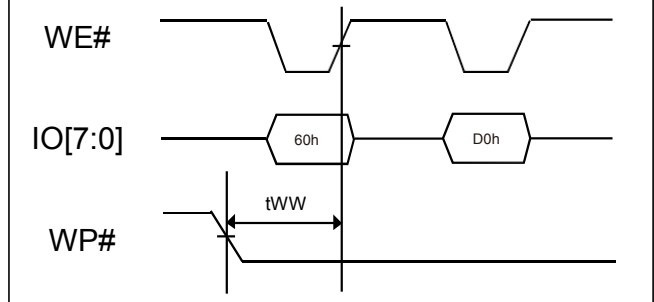

Figure 38-4. Disable Erasing of WP# Signal



## 9. SOFTWARE ALGORITHM

### 9-1. Invalid Blocks (Bad Blocks)

The bad blocks are included in the device while it gets shipped. During the time of using the device, the additional bad blocks might be increasing; therefore, it is recommended to check the bad block marks and avoid using the bad blocks. Furthermore, please read out the bad block information before any erase operation since it may be cleared by any erase operation.

**Figure 39. Bad Blocks**

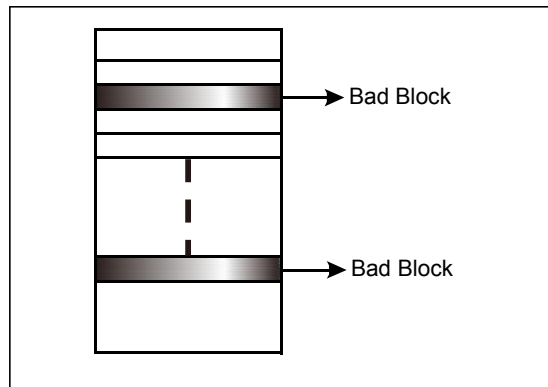

While the device is shipped, the value of all data bytes of the good blocks are FFh. The 1<sup>st</sup> bytes of the 1<sup>st</sup> and 2<sup>nd</sup> page in the spare area for bad block will be 00h. The erase operation at the bad blocks is not recommended.

After the device is installed in the system, the bad block checking is recommended. **Figure 40. Bad Block Test Flow** shows the brief test flow by the system software managing the bad blocks while the bad blocks were found. When a block gets damaged, it should not be used any more.

Due to the blocks are isolated from bit-line by the selected gate, the performance of good blocks will not be impacted by bad ones.

**Table 18. Valid Blocks**

	Density	Min.	Typ.	Max.	Unit	Remark
Valid (Good) Block Number	1Gb	1004		1024	Block	Block 0 is guaranteed to be good at least 1K P/E cycle (with ECC).

### 9-2. Bad Block Test Flow

Although the initial bad blocks are marked by the flash vendor, they could be inadvertently erased and destroyed by a user that does not pay attention to them. To prevent this from occurring, it is necessary to always know where any bad blocks are located. Continually checking for bad block markers during normal use would be very time consuming, so it is highly recommended to initially locate all bad blocks and build a bad block table and reference it during normal NAND flash use. This will prevent having the initial bad block markers erased by an unexpected program or erase operation. Failure to keep track of bad blocks can be fatal for the application. For example, if boot code is programmed into a bad block, a boot up failure may occur. **Figure 40. Bad Block Test Flow** shows the recommended flow for creating a bad block table.

**Figure 40. Bad Block Test Flow**

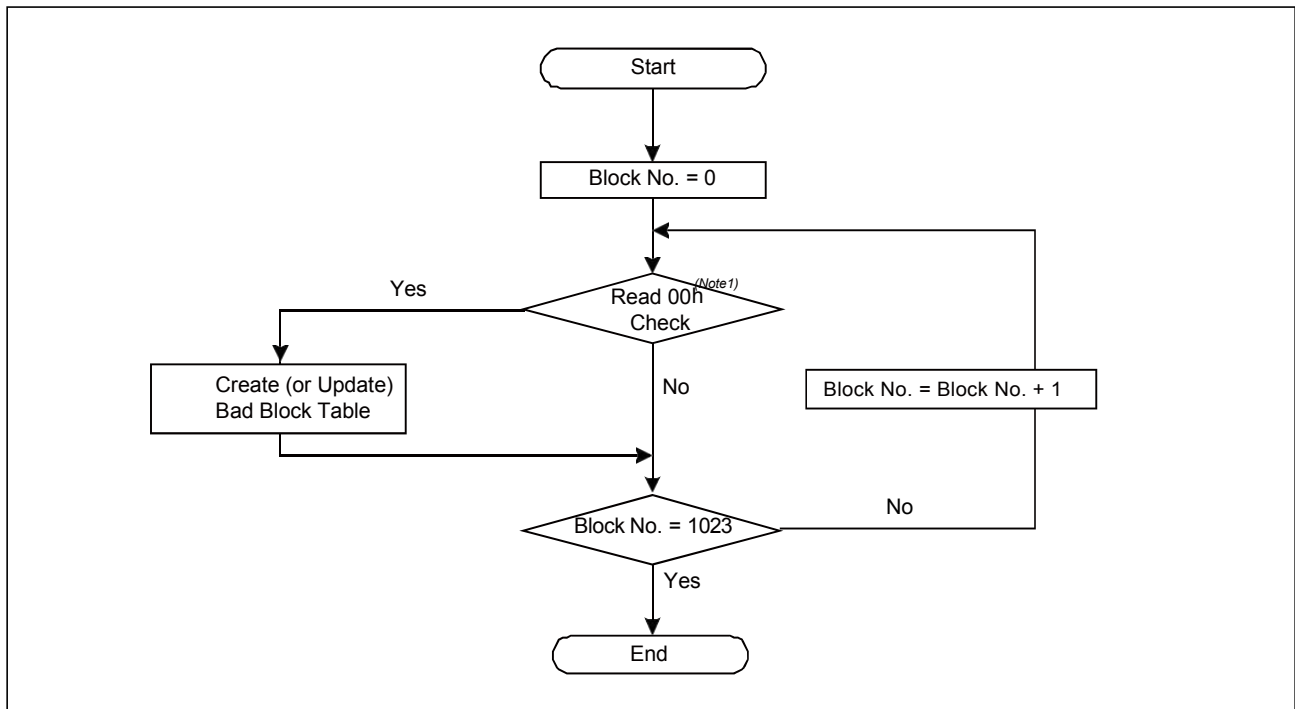

**Note 1:** Read 00h check is at the 1st byte of the 1st and 2nd pages of the block spare area.

### 9-3. Failure Phenomena for Read/Program/Erase Operations

The device may fail during a Read, Program or Erase operation. The following possible failure modes should be considered when implementing a highly reliable system:

**Table 19. Failure Modes**

Failure Mode	Detection and Countermeasure	Sequence
Eraser Failure	Status Read after Erase	Block Replacement
Programming Failure	Status Read after Program	Block Replacement
Read Failure	Read Failure	ECC

### 9-4. Program

It is feasible to reprogram the data into another page (Page B) when an error occurred in Page A by loading from an external buffer. Then create a bad block table or by using another appropriate scheme to prevent further system accesses to Page A.

Figure 41. Failure Modes

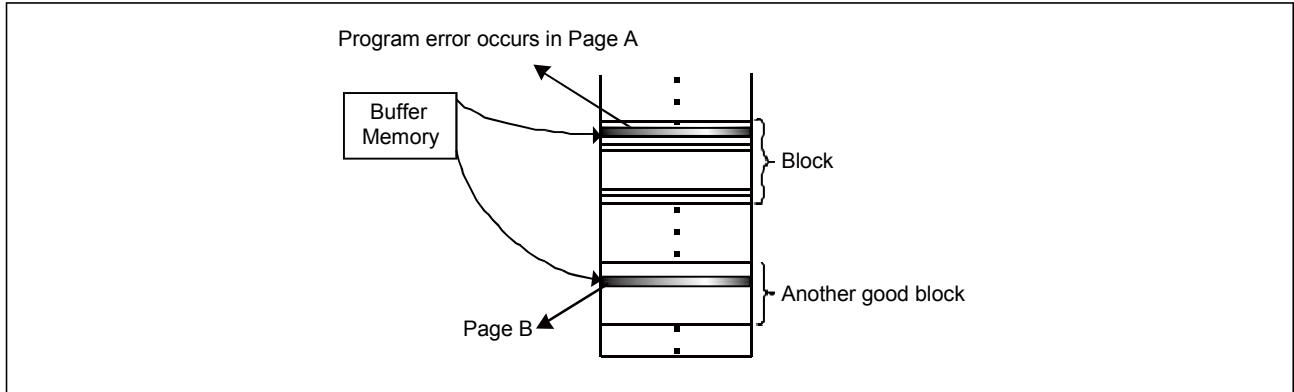
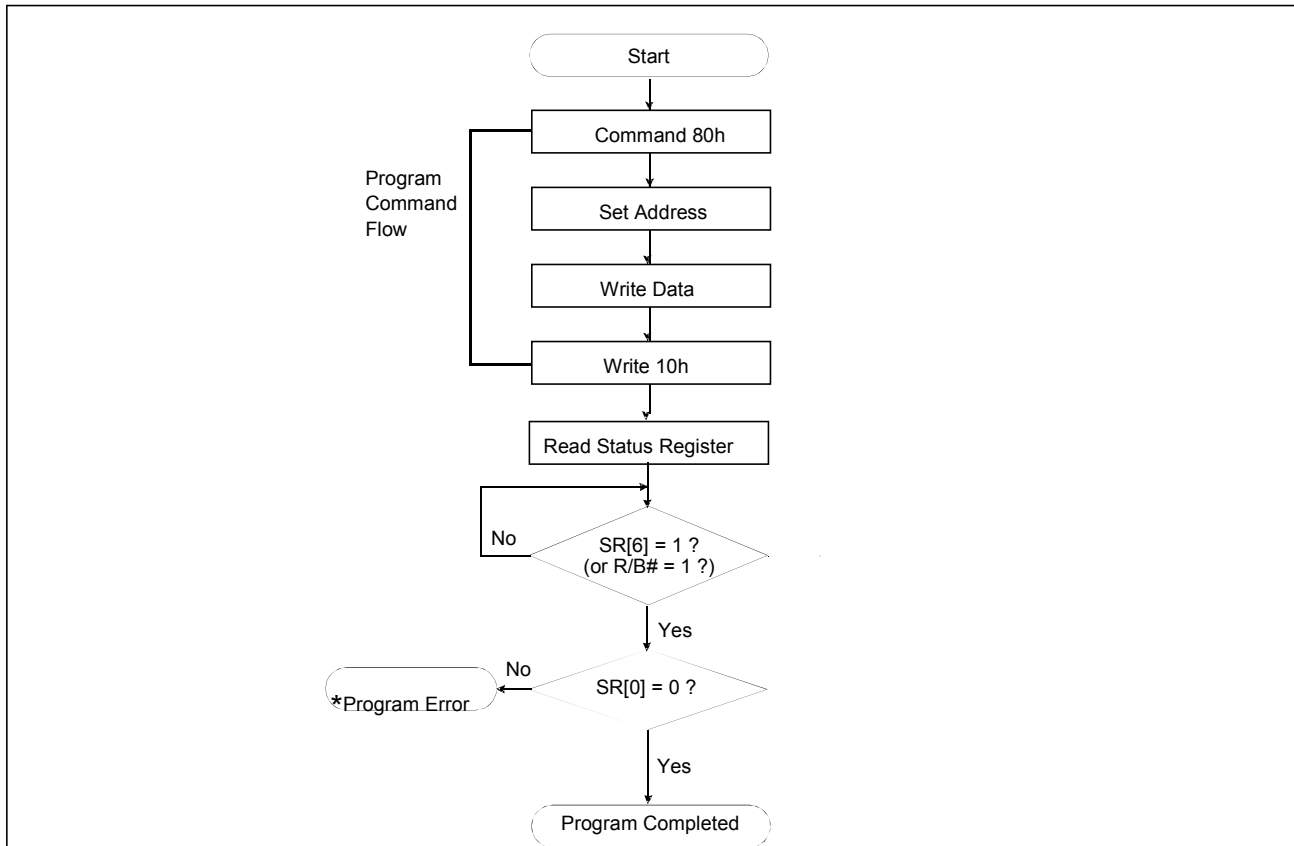

Figure 42. Program Flow Chart



### 9-5. Erase

To prevent future accesses to this bad block, it is feasible to create a table within the system or by using another appropriate scheme when an error occurs in an Erase operation.

Figure 43. Erase Flow Chart

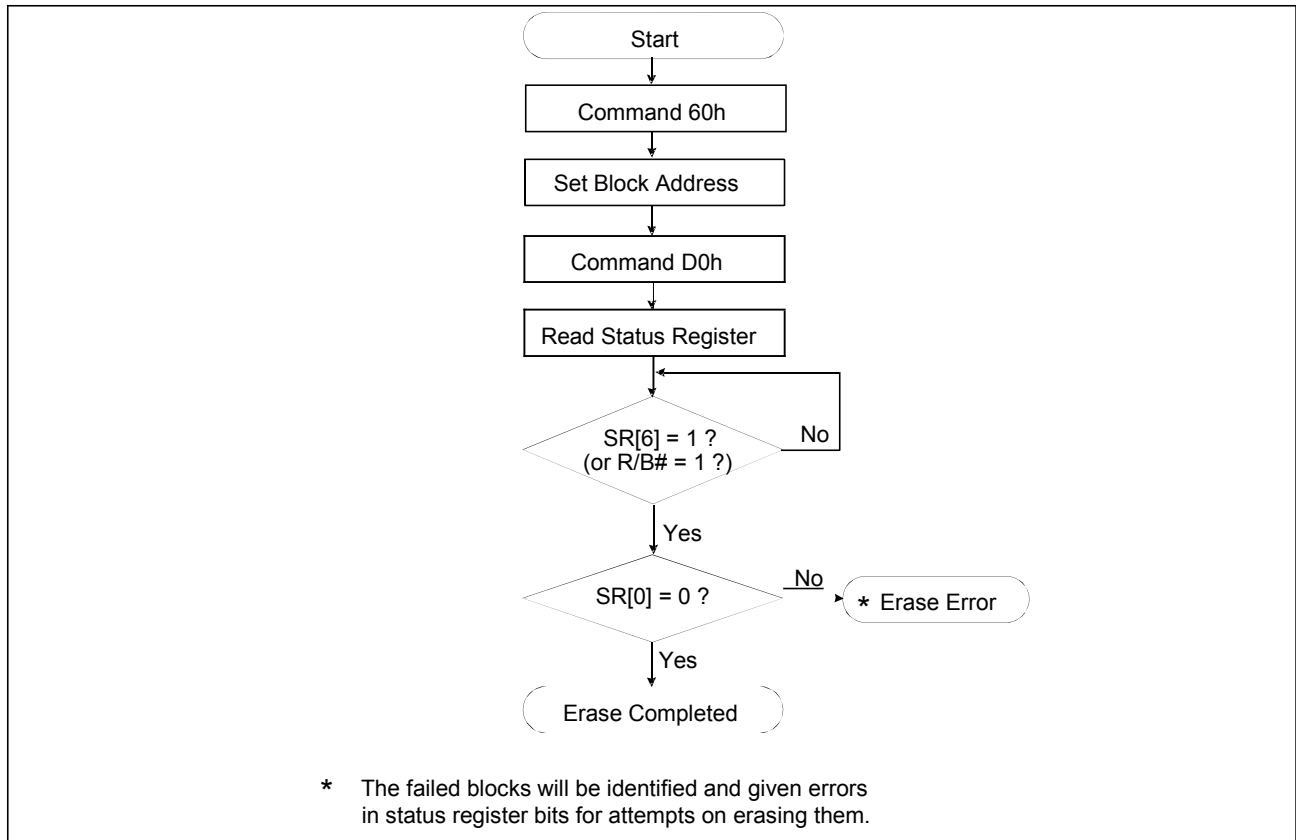
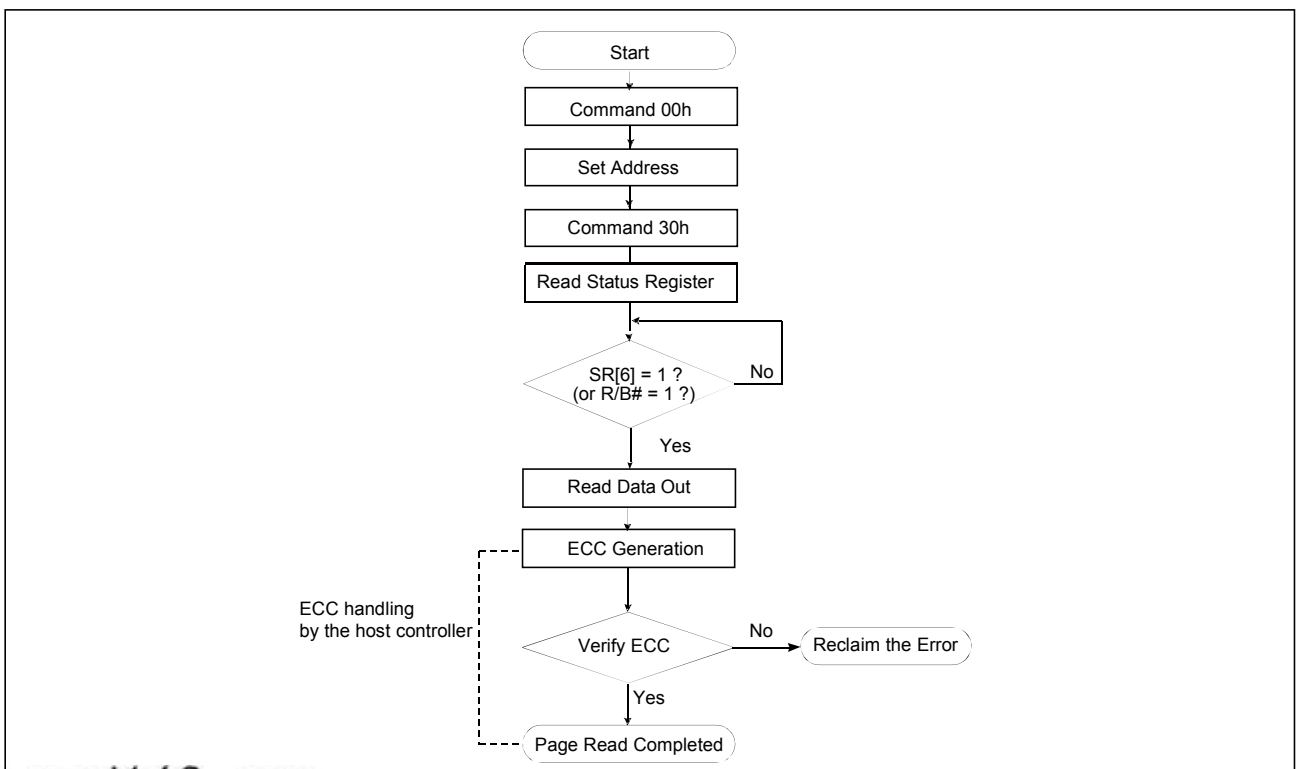
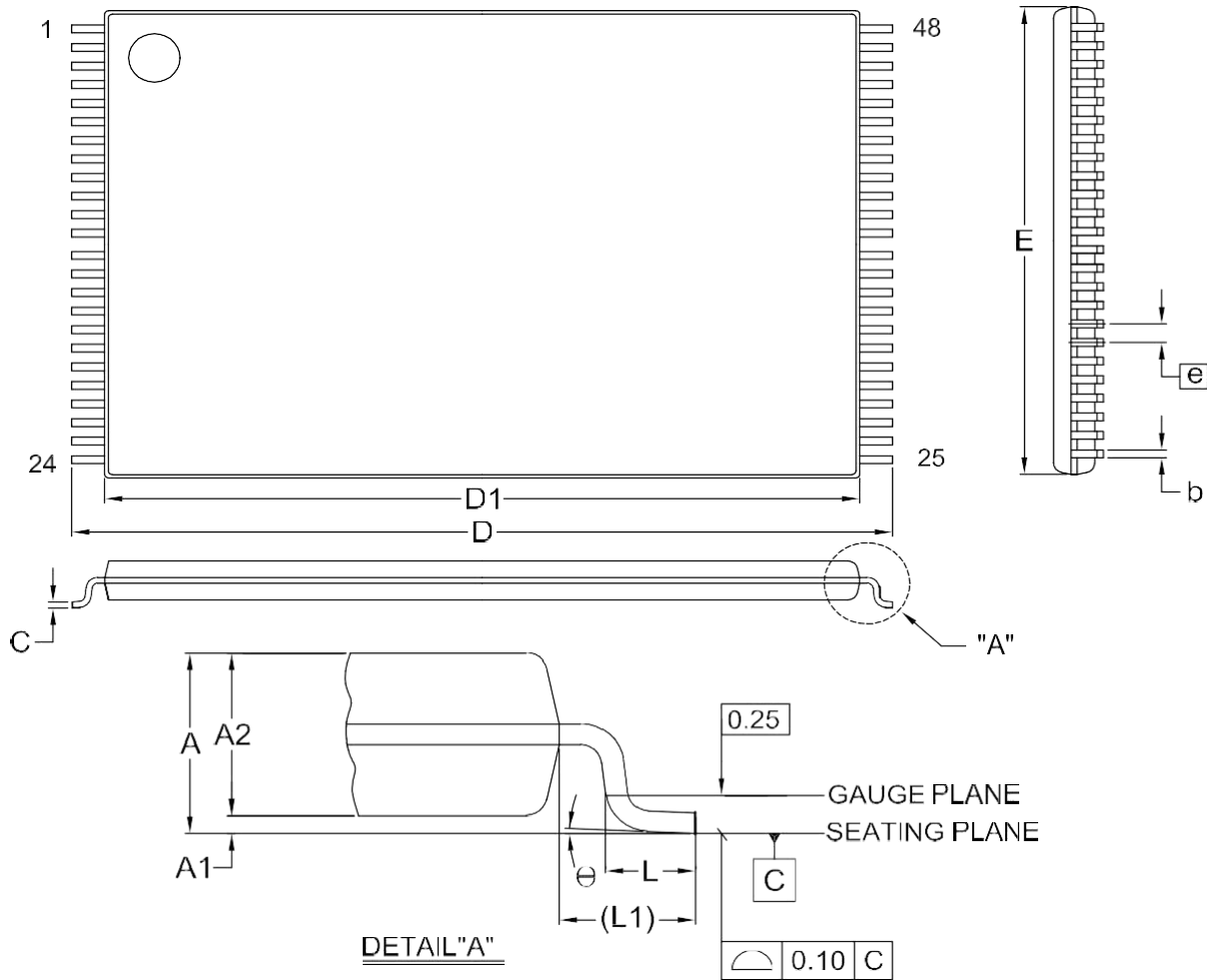

Figure 44. Read Flow Chart



### 10. PACKAGE INFORMATION

Title: Package Outline for TSOP(I) 48L (12X20■■■)NORMAL FORM



Dimensions (inch dimensions are derived from the original mm dimensions)

SYMBOL		A	A1	A2	b	C	D	D1	E	e	L	L1	Θ
UNIT	Min.	---	0.05	0.95	0.17	0.10	19.80	18.30	11.90	---	0.50	0.70	0
	Nom.	---	0.10	1.00	0.20	0.13	20.00	18.40	12.00	0.50	0.60	0.80	5
	Max.	1.20	0.15	1.05	0.27	0.21	20.20	18.50	12.10	---	0.70	0.90	8
Inch	Min.	---	0.002	0.037	0.007	0.004	0.780	0.720	0.469	---	0.020	0.028	0
	Nom.	---	0.004	0.039	0.008	0.005	0.787	0.724	0.472	0.020	0.028	0.031	5
	Max.	0.047	0.006	0.041	0.011	0.008	0.795	0.728	0.476	---	0.028	0.035	8

DWG.NO.	REVISION	REFERENCE			ISSUE DATE
		JEDEC	EIAJ		
6110-1607	8	MO-142			2007/08/03



**Title:** Package Outline for 63-VFBGA (9x11x1.0mm, Ball-pitch: 0.8mm, Ball-diameter: 0.45mm)

TOP VIEW

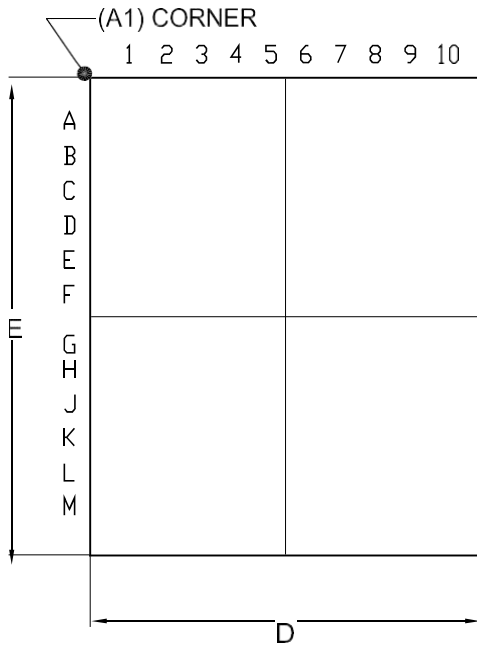

BOTTOM VIEW

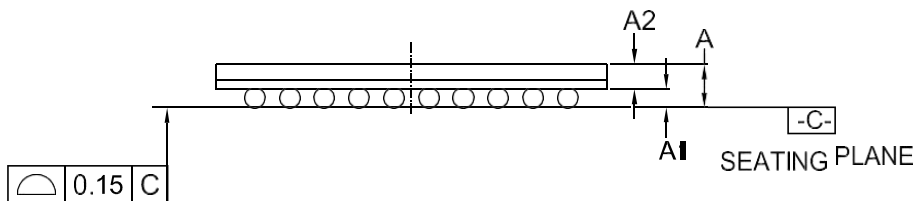
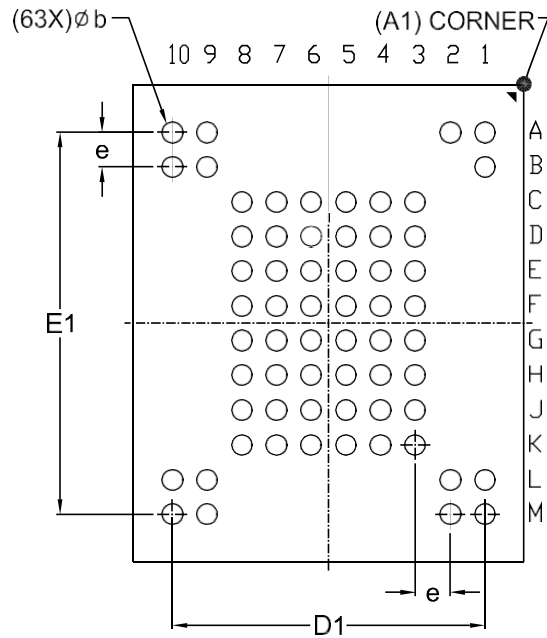

Dimensions (inch dimensions are derived from the original mm dimensions)

SYMBOL	A	A1	A2	b	D	D1	E	E1	e
mm	Min.	0.25	0.55	0.40	8.90	---	10.90	---	---
	Nom.	1.00	0.40	---	9.10	---	11.10	---	---
	Max.	---	0.010	0.022	0.016	0.350	---	0.429	---
Inch	Min.	---	0.012	---	0.354	0.283	0.433	0.346	0.031
	Nom.	0.039	0.016	---	0.020	---	0.437	---	---
	Max.	---	---	---	---	---	---	---	---

Dwg. No.	Revision	Reference		
		JEDEC	EIAJ	
6110-4267	0			

## 11. REVISION HISTORY

Rev. No.	Descriptions	Page	Date
0.01	1. Corrected the value of byte#6-9 of ONFI parameter page	P42	SEP/04/2014
	2. Revised the IO3 of feature address 90h from "x" to "reserved(0)"	P46	
	3. Revised the typical spec of tCBSY from 3us to 5us and tRCBSY from 2us to 3.5us	P57	
0.02	1. Revised title of "Advanced Information" to "Preliminary"	ALL	DEC/30/2014
	2. Corrected tALS timing waveform as ALE high till WE# high	P25,53	
	3. Added Figure 33 PT Pin and Block Protection Mode Operation	P55	
	4. ICC1/ICC2 (typical) are improved from 20mA to 15mA	P57	
	5. Revised the bad block mark from non-FFh to 00h, also revised the page of bad block mark from 1st or 2nd page to 1st and 2nd page	P66,67	
1.0	1. Removed "Preliminary" title	ALL	FEB/02/2015
1.1	1. Added negative overshoot/positive overshoot waveforms	P56	JUN/30/2015
1.2	1. Added the tRST=5us for the device reset time from idle	P59	MAY/27/2016
	2. Modification of the power-on/off sequence: supplement the CE# signal, supplement the WE# single waveform with WE#=0 without toggle during the power-on period.	P64	
	3. Modified wording of "at least 1K P/E(with ECC)" on block#0	P66	



Except for customized products which have been expressly identified in the applicable agreement, Macronix's products are designed, developed, and/or manufactured for ordinary business, industrial, personal, and/or household applications only, and not for use in any applications which may, directly or indirectly, cause death, personal injury, or severe property damages. In the event Macronix products are used in contradicted to their target usage above, the buyer shall take any and all actions to ensure said Macronix's product qualified for its actual use in accordance with the applicable laws and regulations; and Macronix as well as it's suppliers and/or distributors shall be released from any and all liability arisen therefrom.

Copyright© Macronix International Co., Ltd. 2015-2016. All rights reserved, including the trademarks and tradename thereof, such as Macronix, MXIC, MXIC Logo, MX Logo, Integrated Solutions Provider, NBit, Nbit, NBit, Macronix NBit, eLiteFlash, HybridNVM, HybridFlash, XtraROM, Phines, KH Logo, BE-SONOS, KSMC, Kingtech, MXSMIO, Macronix vEE, Macronix MAP, Rich Audio, Rich Book, Rich TV, and FitCAM. The names and brands of third party referred thereto (if any) are for identification purposes only.

For the contact and order information, please visit Macronix's Web site at: <http://www.macronix.com>

**MACRONIX INTERNATIONAL CO., LTD.**

<http://www.macronix.com>

MACRONIX INTERNATIONAL CO., LTD. reserves the right to change product and specifications without notice.