



MX35LF1GE4AB
MX35LF2GE4AB

3V, 1Gb/2G-bit Serial NAND Flash Memory

MX35LFxGE4AB

Contents

1. FEATURES.....	5
2. GENERAL DESCRIPTIONS.....	6
Figure 1. Logic Diagram.....	6
3. ORDERING INFORMATION.....	7
4. BALL ASSIGNMENT AND DESCRIPTIONS.....	8
Figure 2. 16-SOP (300mil).....	8
5. PIN DESCRIPTIONS.....	8
Figure 3. 8-WSON (8x6mm) (1Gb only).....	8
6. DEVICE OPERATION.....	9
Figure 4. Serial Mode Supported.....	9
7. ADDRESS MAPPING.....	10
8. COMMAND DESCRIPTION.....	11
Table 1. Command Set.....	11
8-1. WRITE Operations.....	12
8-1-1. Write Enable.....	12
Figure 5. Write Enable (WREN) Sequence.....	12
8-1-2. Write Disable (04h).....	12
Figure 6. Write Disable (WRDI) Sequence.....	12
8-2. Feature Operations.....	13
8-2-1. GET Feature (0Fh) and SET Feature (1Fh).....	13
Table 2-1. Feature Settings (For 2Gb).....	13
Table 2-2. Feature Settings (For 1Gb).....	13
Figure 7. GET FEATURE (0Fh) Timing.....	14
Figure 8. SET FEATURE (1Fh) Timing.....	14
8-3. READ Operations.....	15
8-3-1. PAGE READ (13h).....	15
Table 3. Wrap Address bit Table (Only for 1Gb).....	15
8-3-2. QE bit.....	15
Figure 9. PAGE READ (13h) Timing x1.....	16
Figure 10. RANDOM DATA READ (03h or 0Bh) Timing.....	17
Figure 11. READ FROM CACHE x 2.....	18
Figure 12. READ FROM CACHE x 4.....	19



8-3-3. Page Read Cache Sequential (31h) / Page Read Cache End (3Fh) - For 1G Only	20
Figure 13. Page Read Cache Sequential (31h).....	20
Figure 14. Page Read Cache End (3Fh).....	21
8-3-4. READ ID (9Fh)	22
Table 4. READ ID Table.....	22
Figure 15. READ ID (9Fh) Timing.....	22
8-4. Parameter Page	23
Table 5. Parameter Page Data Structure.....	24
8-5. UniqueID Page	25
8-6. Internal ECC Status Read (For 1Gb only)	26
Table 6-1. The ECCSR (Internal ECC Status Register) Bits.....	26
Table 6-2. The Definition of Internal ECC Status.....	26
Figure 16. The Page Structure and Internal ECC Segments.....	26
Figure 17. The Sequence of Internal ECC Status Read.....	27
8-7. Program Operations	28
8-7-1. PAGE PROGRAM	28
Figure 18. PROGRAM LOAD (02h) Timing.....	28
Figure 19. PROGRAM LOAD RANDOM DATA (84h) Timing.....	29
8-7-2. QUAD IO PAGE PROGRAM	30
Figure 20. PROGRAM LOAD X4 (32h) Timing.....	30
Figure 21. QUAD IO PROGRAM RANDOM INPUT (34h) Timing.....	31
Figure 22. PROGRAM EXECUTE (10h) Timing.....	32
9. BLOCK OPERATIONS	33
9-1. Block Erase (D8h)	33
Figure 23. Block Erase (BE) Sequence.....	33
10. Feature Register	34
10-1. Block Protection Feature	34
Table 7-1. Definition of Protection Bits (BPx) (For 2Gb).....	35
Table 7-2. Definition of Protection Bits (For 1Gb).....	35
10-2. Secure OTP (One-Time-Programmable) Feature	36
Table 8. Secure OTP States.....	36
10-3. Status Register	37
Table 9. Status Register Bit Descriptions.....	37
11. SOFTWARE ALGORITHM	38
11-1. Invalid Blocks (Bad Blocks)	38



Figure 24. Bad Blocks.....	38
Table 10. Valid Blocks.....	38
11-2. Bad Block Test Flow.....	39
Figure 25. Bad Block Test Flow.....	39
11-3. Failure Phenomena for Read/Program/Erase Operations.....	39
Table 11. Failure Modes.....	39
11-3-1. Internal ECC Enabled/Disabled.....	40
Table 12. The Distribution of ECC Segment and Spare Area.....	40
12. DEVICE POWER-UP.....	41
12-1. Power-up.....	41
Figure 26. Power On Sequence.....	41
13. PARAMETERS.....	42
13-1. ABSOLUTE MAXIMUM RATINGS.....	42
Figure 27. Maximum Negative Overshoot Waveform.....	42
Table 13. AC Testing Conditions.....	42
Table 14. Capacitance.....	42
Table 15. Operating Range.....	42
Figure 28. Maximum Positive Overshoot Waveform.....	42
Table 16. DC Characteristics.....	43
Table 17. General Timing Characteristics.....	43
Table 18. PROGRAM/READ/ERASE Characteristics.....	43
Figure 29. WP# Setup Timing and Hold Timing during SET FEATURE when BPRWD=1.....	44
Figure 30. Serial Input Timing.....	44
Figure 31. Serial Output Timing.....	44
Figure 32. Hold Timing.....	45
14-1. 8-WSON (8x6mm), E.P. 3.4x4.3mm, Recommended for new design.....	46
14. PACKAGE INFORMATION.....	46
14-2. 16-SOP (300mil).....	47
15. REVISION HISTORY.....	48

1. FEATURES

- 1Gb/2Gb SLC NAND Flash
 - Bus: x4
 - Page size: (2048+64) byte
 - Block size: (128K+4K) byte
- **Fast Read Access**
 - Supports Random data read out by x1 x2 & x4 modes, (1-1-1, 1-1-2, 1-1-4)^{Note 2}
 - Latency of array to register: 25us^{Note 1}
 - Frequency: 104MHz
- **Page Program Operation**
 - Page program time: 300us (typ)^{Note 1}
- **Block Erase Operation**
 - Block erase time: 1ms (typ.)
- **Single Voltage Operation:**
 - VCC: 2.7 to 3.6V
- **BP bits for block group protection**
- **Low Power Dissipation**
 - Max 30mA
Active current (Read/Program/Erase)
- **Sleep Mode**
 - 50uA (Max) standby current
- **High Reliability**
 - Program/Erase Endurance: Typical 100K cycles (with internal 4-bit ECC per (512+16) Byte)
 - Data Retention: 10 years
- **Wide Temperature Operating Range**
 - 40°C to +85°C
- **Package:**
 - 1) 8-WSON (8x6mm) for 1Gb
 - 2) 16-SOP (300mil) for 2GbAll packaged devices are RoHS Compliant and Halogen-free.

Note 1. Please refer to the t_{RD_ECC} and t_{PROG_ECC} specifications if internal ECC function is turned on.

Note 2. Which indicates the number of I/O for command, address and data.

2. GENERAL DESCRIPTIONS

The MX35LFxGE4AB is a 1Gb/2Gb SLC NAND Flash memory device with Serial interface.

The memory array of this device adopted the same cell architecture as the parallel NAND, however implementing the industry standard serial interface.

An internal 4-bit ECC logic is implemented in the chip, which is enabled by default. The internal ECC can be disabled or enabled again by command. When the internal 4-bit ECC logic is disabled, the host side needs to handle the 4-bit ECC by host micro controller.

Figure 1. Logic Diagram

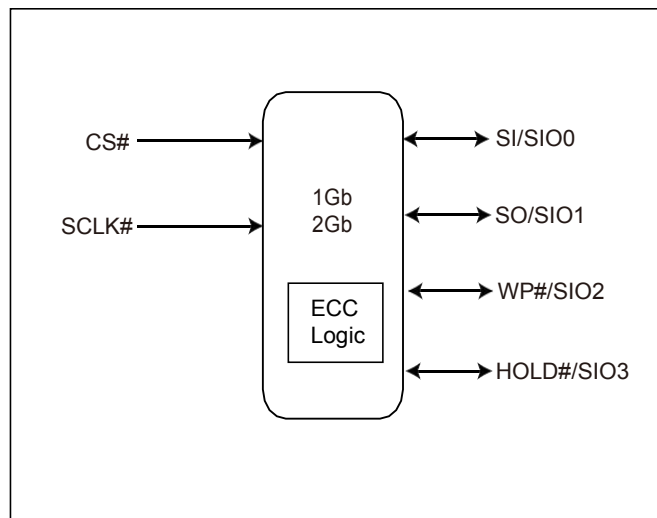

3. ORDERING INFORMATION

Part Name Description

Macronix NAND Flash devices are available in different configurations and densities. Verify valid part numbers by using Macronix's product search at <http://www.Macronix.com>. Contact Macronix sales for devices not found.

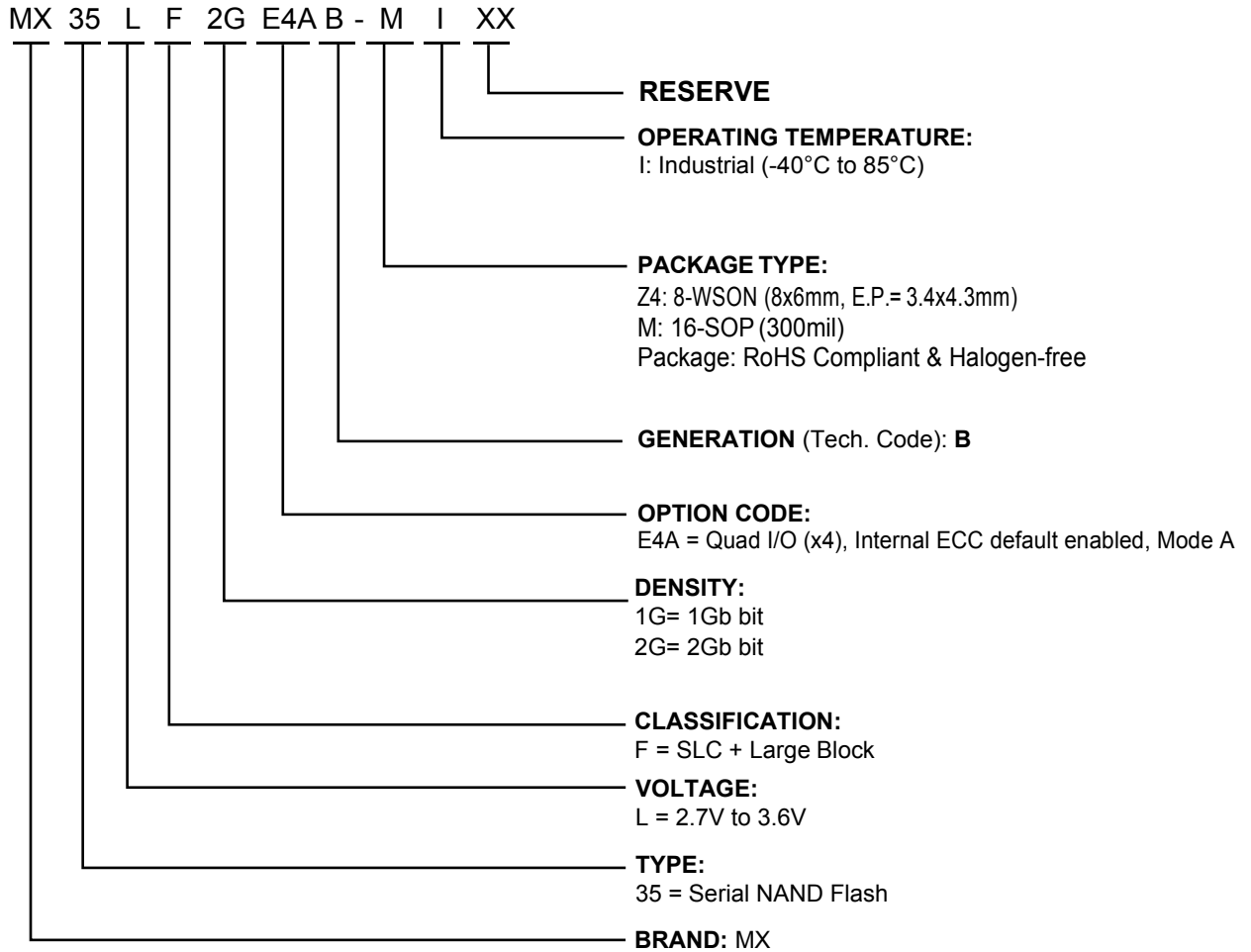

Please contact Macronix regional sales for the latest product selection and available form factors.

Part Number	Density	Organization	VCC Range	Package	Temperature Grade
MX35LF2GE4AB-MI	2Gb	x4	3V	16-SOP	Industrial
MX35LF1GE4AB-Z4I	1Gb	x4	3V	8-WSON (E.P.=3.4x4.3mm)	Industrial

4. BALL ASSIGNMENT AND DESCRIPTIONS

Figure 2. 16-SOP (300mil)

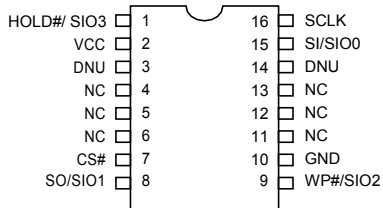
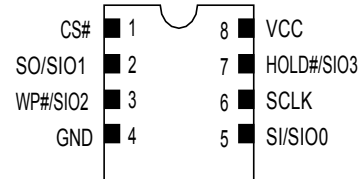

Figure 3. 8-WSON (8x6mm) (1Gb only)



5. PIN DESCRIPTIONS

SYMBOL	DESCRIPTION
CS#	Chip Select
SI/SIO0	Serial Data Input (for 1 x I/O)/ Serial Data Input & Output (for 2xI/O or 4xI/O read mode)
SO/SIO1	Serial Data Output (for 1 x I/O)/ Serial Data Input & Output (for 2xI/O or 4xI/O read mode)
SCLK	Clock Input
WP#/SIO2	Write protection: connect to GND or Serial Data Input & Output (for 4xI/O read mode)
HOLD#/SIO3	Hold or Serial Data Input & Output (for 4xI/O read mode)
VCC	+ 3V Power Supply
GND	Ground
NC	No Connection
DNU	Do not use

6. DEVICE OPERATION

1. Before a command is issued, status register should be checked via get features operations to ensure device is ready for the intended operation.
2. When incorrect command is inputted to this device, this device becomes standby mode and keeps the standby mode until next CS# falling edge. In standby mode, SO pin of this device should be High-Z.
3. When correct command is inputted to this device, this device becomes active mode and keeps the active mode until next CS# rising edge.
4. Input data is latched on the rising edge of Serial Clock (SCLK) and data shifts out on the falling edge of SCLK. The difference of Serial mode 0 and mode 3 is shown as "**Figure 4. Serial Mode Supported**".
5. During the progress of Write Status Register, Program, Erase operation, to access the memory array is neglected and not affect the current operation of Write Status Register, Program, Erase.

Figure 4. Serial Mode Supported

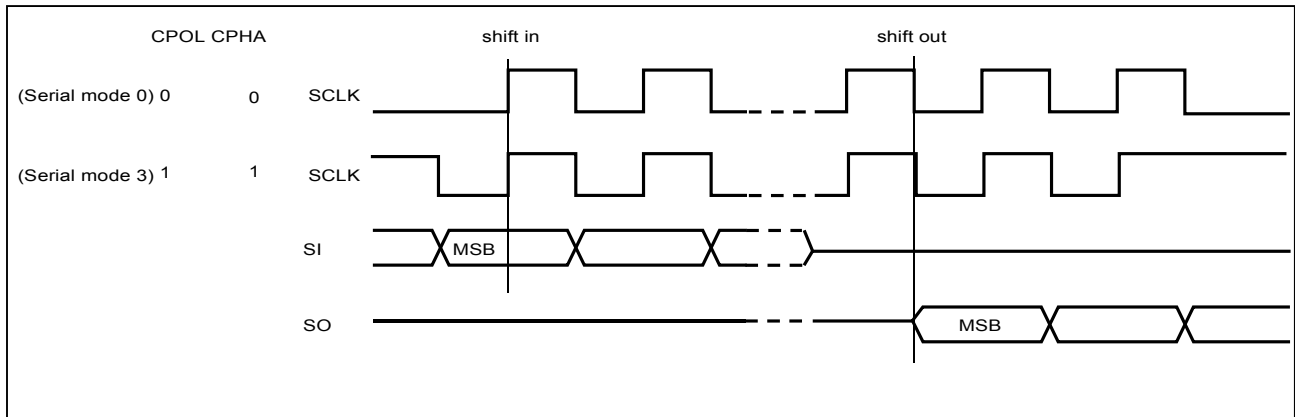

7. ADDRESS MAPPING

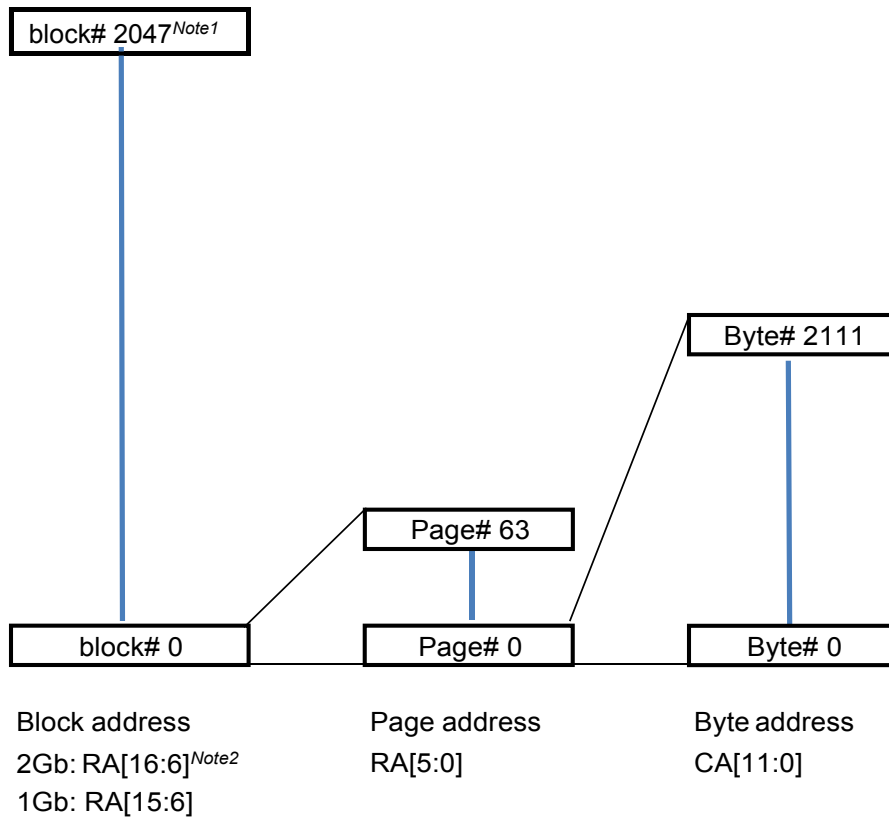

Note 1: 2047 for 2Gb, 1023 for 1Gb

Note 2: RA[6] is for plane select, for 2Gb

8. COMMAND DESCRIPTION

Table 1. Command Set

Read/Write Array Commands

Command Type	GET FEATURE	SET FEATURE	PAGE READ	READ FROM CACHE	READ FROM CACHE x2
Command Code	0Fh	1Fh	13h	03h, 0Bh	3Bh
Address Bytes	1	1	3	2	2
Dummy Bytes	0	0	0	1	1
Data Bytes	1	1	0	1 to 2112	1 to 2112
Actions	Get features	Set features	Array read	Output cache data on SO	Output cache data on SI and SO

Command Type	READ FROM CACHE x4	PAGE Read Cache Sequential (Note1)	PAGE Read Cache End (Note1)	READ ID	Internal ECC Status Read (Note2)	BLOCK ERASE	PROGRAM EXECUTE
Command Code	6Bh	31h	3Fh	9Fh	7Ch	D8h	10h
Address Bytes	2	0	0	0	0	3	3
Dummy Bytes	1	0	0	1	1	0	0
Data Bytes	1 to 2112	1 to 2112	1 to 2112	2	1	0	0
Actions	Output cache data on SI, SO, WP#, HOLD#	The next page data is transferred to buffer	The last page data is transferred to buffer	Read device ID	Internal ECC Status Output	Block erase	Enter block/page address, no data, execute

Command Type	PROGRAM LOAD	PROGRAM LOAD RANDOM DATA	WRITE ENABLE	WRITE DISABLE	PROGRAM LOAD x4	PROGRAM LOAD RANDOM DATA x4	RESET
Command Code	02h	84h	06h	04h	32h	34h	FFh
Address Bytes	2	2	0	0	2	2	0
Dummy Bytes	0	0	0	0	0	0	0
Data Bytes	1 to 2112	1 to 2112	0	0	1 to 2112	1 to 2112	0
Actions	Load program data with cache reset first	Load program data without cache reset			Program Load operation with X4 data input	Program Load random data operation with X4 data input	Reset the device

Notes:

1. The 31h & 3Fh command are only for 1Gb.
2. The 7Ch command is only for 1Gb. For the internal ECC status, which may also check by the Get feature command operation.

8-1. WRITE Operations

8-1-1. Write Enable

The Write Enable (WREN, 06h) instruction is for setting Write Enable Latch (WEL) bit. For those instructions like Page Program, Secure OTP program, Block Erase, which are intended to change the device content WEL bit should be set every time after the WREN instruction setting the WEL bit.

The sequence of issuing WREN instruction is: CS# goes low→sending WREN instruction code→ CS# goes high.

Figure 5. Write Enable (WREN) Sequence

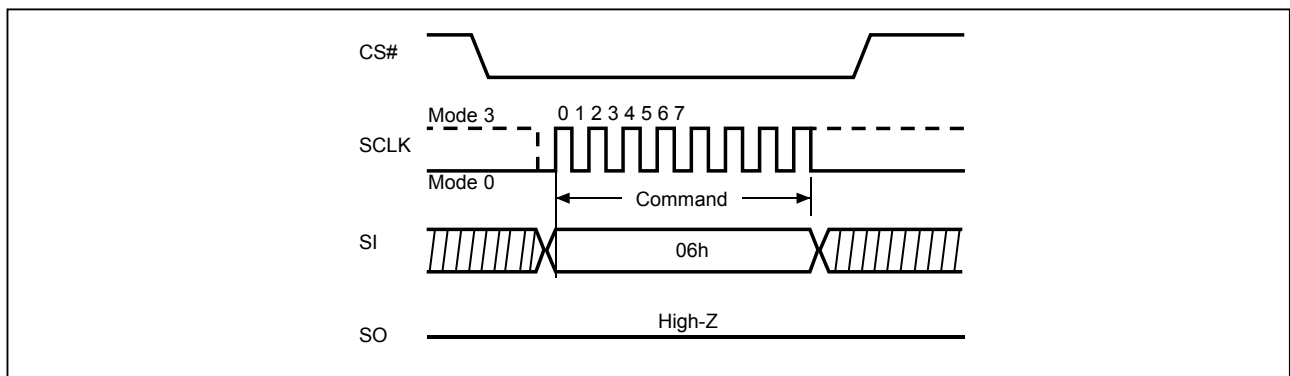

8-1-2. Write Disable (04h)

The Write Disable (WRDI, 04h) instruction is to reset Write Enable Latch (WEL) bit.

The sequence of issuing WRDI instruction is: CS# goes low→sending WRDI instruction code→CS# goes high. It disables the following operations:

- Block Erase
- Secure OTP program
- Page program

Figure 6. Write Disable (WRDI) Sequence

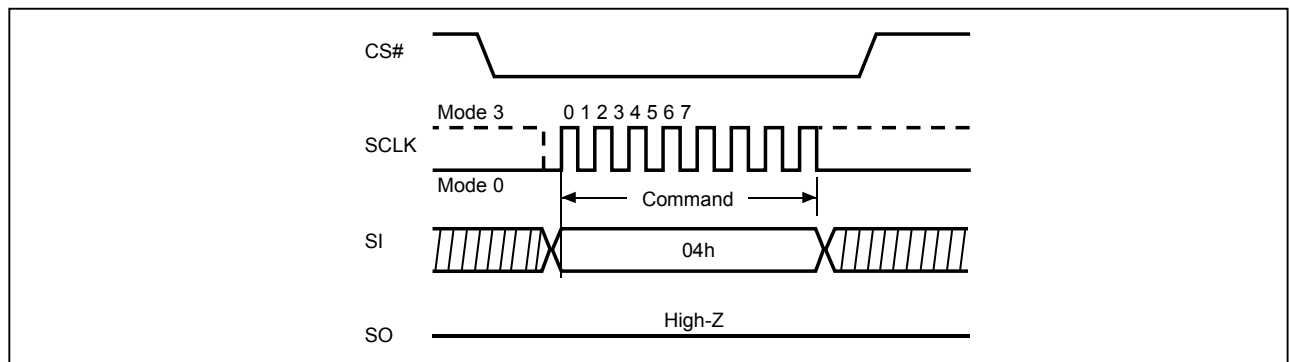

8-2. Feature Operations

8-2-1. GET Feature (0Fh) and SET Feature (1Fh)

By issuing a one byte address into the feature address, the device may then decide if it's a feature read or feature modification. (0Fh) is for the "GET FEATURE"; (1Fh) is for the "SET FEATURE".

The RESET command (FFh) will not clear the previous feature setting, the feature setting data bits remain until the power is being cycled or modified by the settings in the table below. After a RESET command (FFh) is issued, the Status register OIP bit0 will go high. This bit can be polled to determine when the Reset operation is complete, as it will return to the default value (0) after the reset operation is finished. Issuing the RESET command (FFh) has no effect on the Block Protection and Configuration registers.

The Block Protection and Configuration registers (except Secure OTP Protect bit of 1Gb) will return to their default state after a power cycle, and can also be changed using the Set Feature command. Issuing the Get Feature command to read the selected register value will not affect register content.

Table 2-1. Feature Settings (For 2Gb)

Register	Address	Data Bits								
		bit7	bit6	bit5	bit4	bit3	bit2	bit1	bit0	
Configuration	B0h	Secure OTP Protect	Secure OTP Enable	Reserved	ECC enabled	Reserved	Reserved	Reserved	Reserved	QE
Status	C0h	Reserved	Reserved	ECC_S1	ECC_S0	P_Fail	E_Fail	WEL	OIP	
Block Protection	A0h	BPRWD ¹	Reserved	BP2	BP1	BP0	Reserved	Reserved	Reserved	

Note 1: If BPRWD is enabled and WP# is LOW, then the block protection register cannot be changed.

Table 2-2. Feature Settings (For 1Gb)

Register	Address	Data Bits								
		bit7	bit6	bit5	bit4	bit3	bit2	bit1	bit0	
Secure OTP	B0h	Secure OTP Protect	Secure OTP Enable	Reserved	ECC enabled	Reserved	Reserved	Reserved	Reserved	QE
Status	C0h	Reserved	CRBSY	ECC_S1	ECC_S0	P_Fail	E_Fail	WEL	OIP	
Block Protection	A0h	BPRWD ¹	Reserved	BP2	BP1	BP0	Invert	Complementary	SP ²	

Note 1: If BPRWD is enabled and WP# is LOW, then the block protection register cannot be changed.

Note 2: SP bit is for Solid-protection. Once the SP bit sets as 1, the rest of the protection bits (BPx bits, Invert bits, complementary bits) cannot be changed during the current power cycle.

Figure 7. GET FEATURE (0Fh) Timing

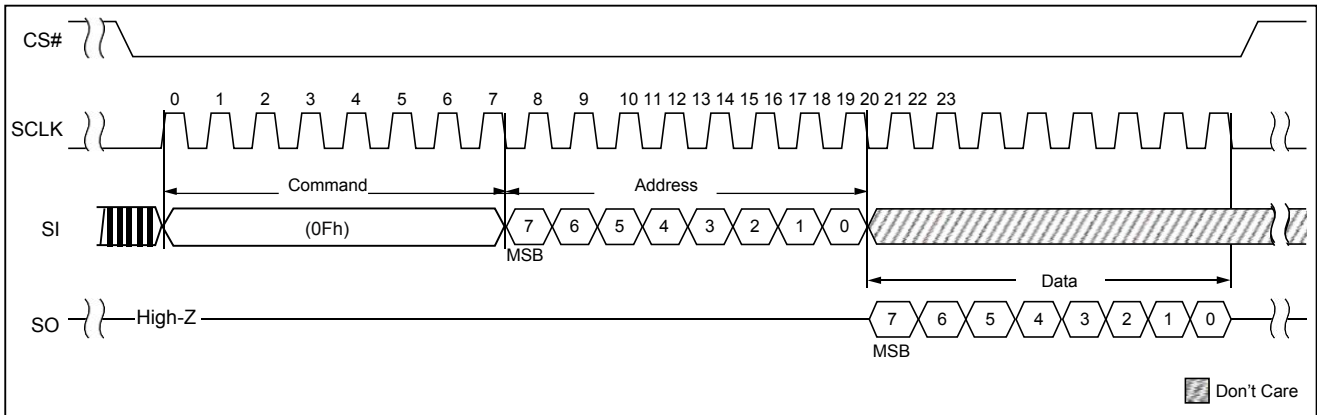
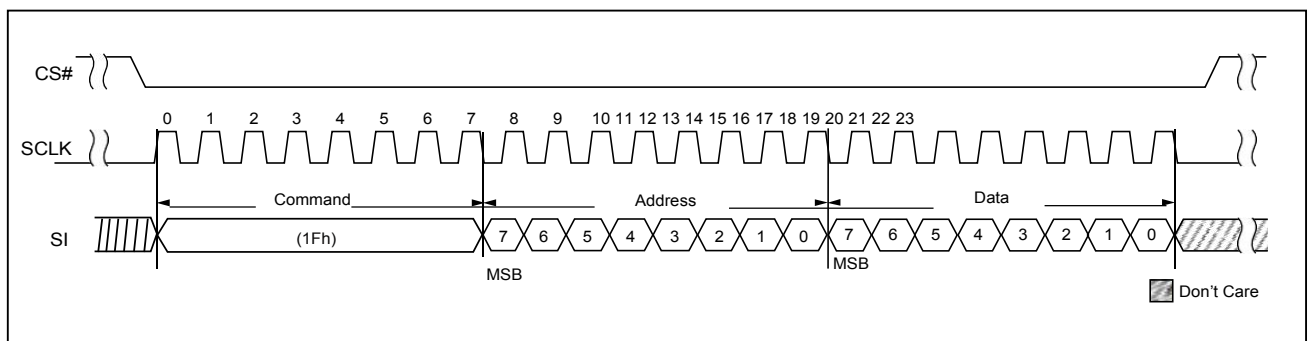

Figure 8. SET FEATURE (1Fh) Timing



8-3. READ Operations

The device supports "Power-on Read" function, after power up, the device will automatically load the data of the 1st page of 1st block from array to cache. The host micro-controller may directly read the 1st page of 1st block data from the cache buffer. The data is also under the internal ECC protection.

8-3-1. PAGE READ (13h)

The page read operation transfers data from array to cache by issuing the page read (13h) command followed by the 24-bit address (including the dummy/block/page address).

The device will have a period of time (tRD) being busy after the CS# goes high. The 0Fh (GET FEATURE) may be used to poll the operation status.

After read operation is completed, the RANDOM DATA READ (03H or 0Bh), Read from cache (x2) (3Bh), and Read from cache (x4) (6Bh) may be issued to fetch the data.

Wrap Read Operation (Only for 1Gb)

For 1Gb, there are four wrap address bits which define the four wrap length as below table. After the Read from cache command (03h, 0Bh, 3Bh, 6Bh), setting the wrap address bits, and followed by the 12-bit column address to define the starting address. The starting address for wrap read only can be 0 - 2112. The data will be output from the starting address, once it reaches the end of the boundary of wrap length, the data will be wrap around the beginning starting wrap address until CS# goes high.

Table 3. Wrap Address bit Table (Only for 1Gb)

Wrap [1]	Wrap [0]	Wrap Length (byte)
0	0	2112
0	1	2048
1	0	64
1	1	16

8-3-2. QE bit

The Quad Enable (QE) bit, volatile bit, while it is "0" (factory default), it performs non-Quad and WP#, HOLD# are enabled. While QE is "1", it performs Quad I/O mode and WP#, HOLD# are disabled. In another word, if the system goes into four I/O mode (QE=1), the feature of Hardware Protection Mode (HPM) and HOLD will be disabled. Upon power cycle, the QE bit will go into the factory default setting "0".

Figure 9. PAGE READ (13h) Timing x1

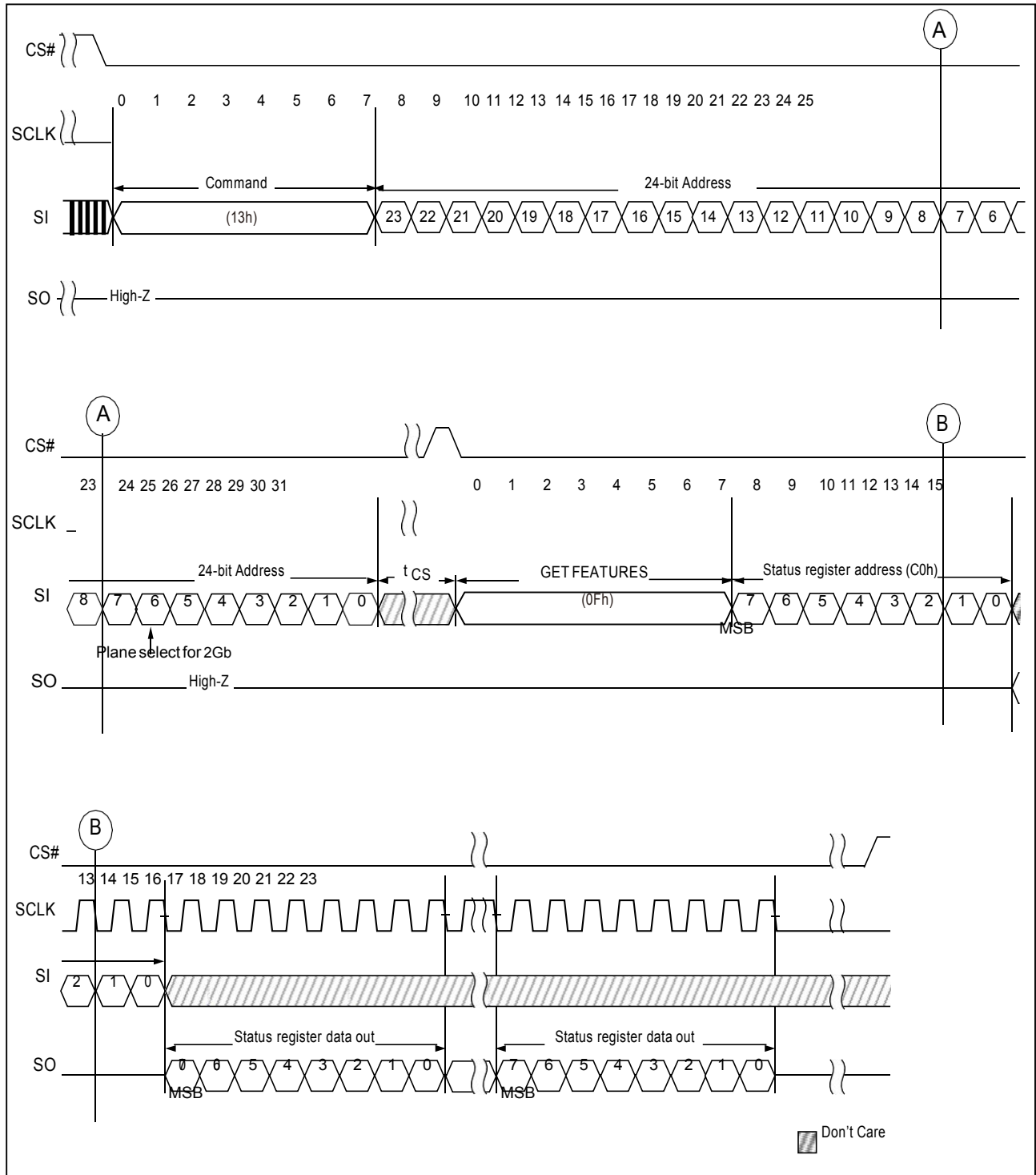

Figure 10. RANDOM DATA READ (03h or 0Bh) Timing

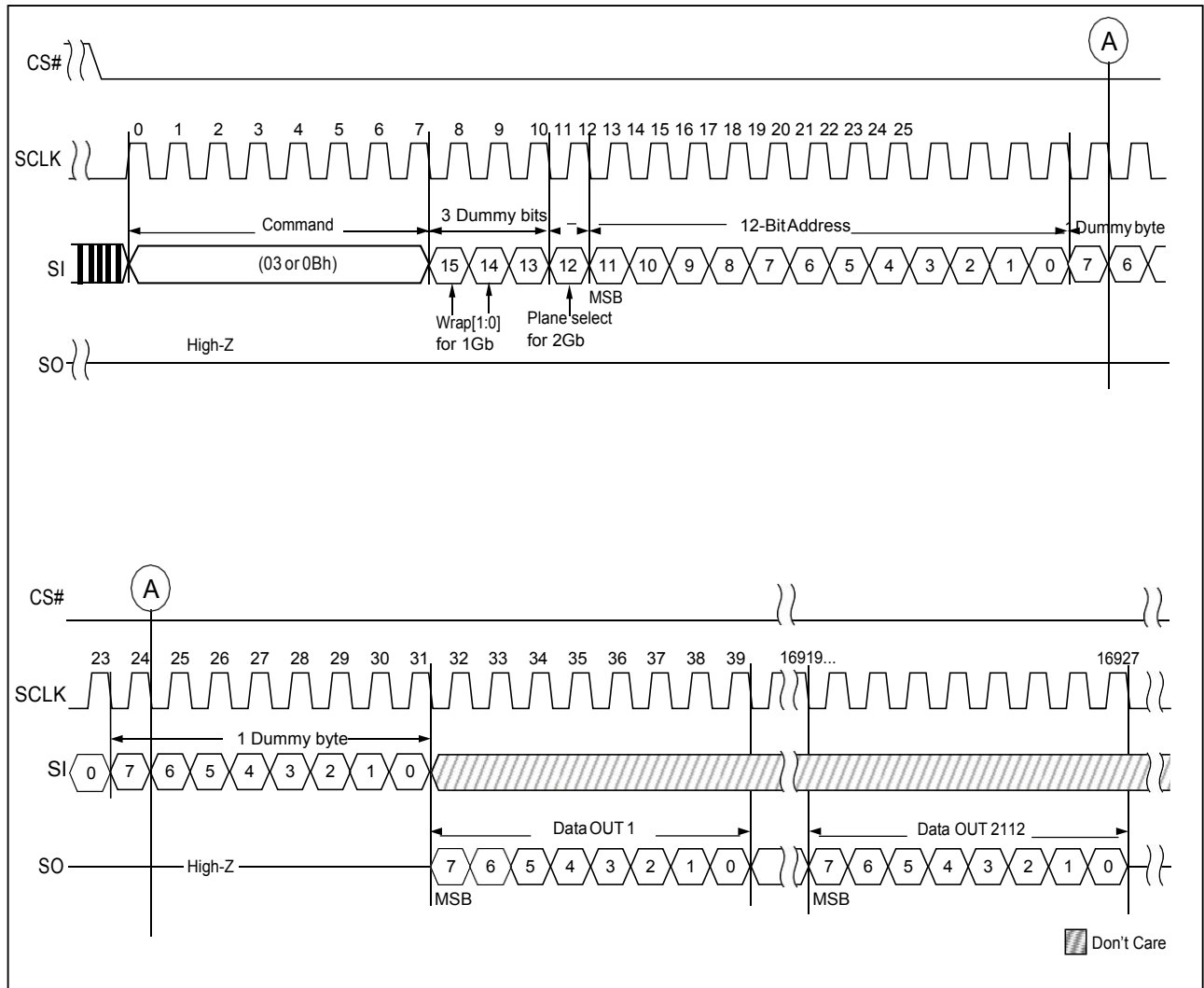

Figure 11. READ FROM CACHE x 2

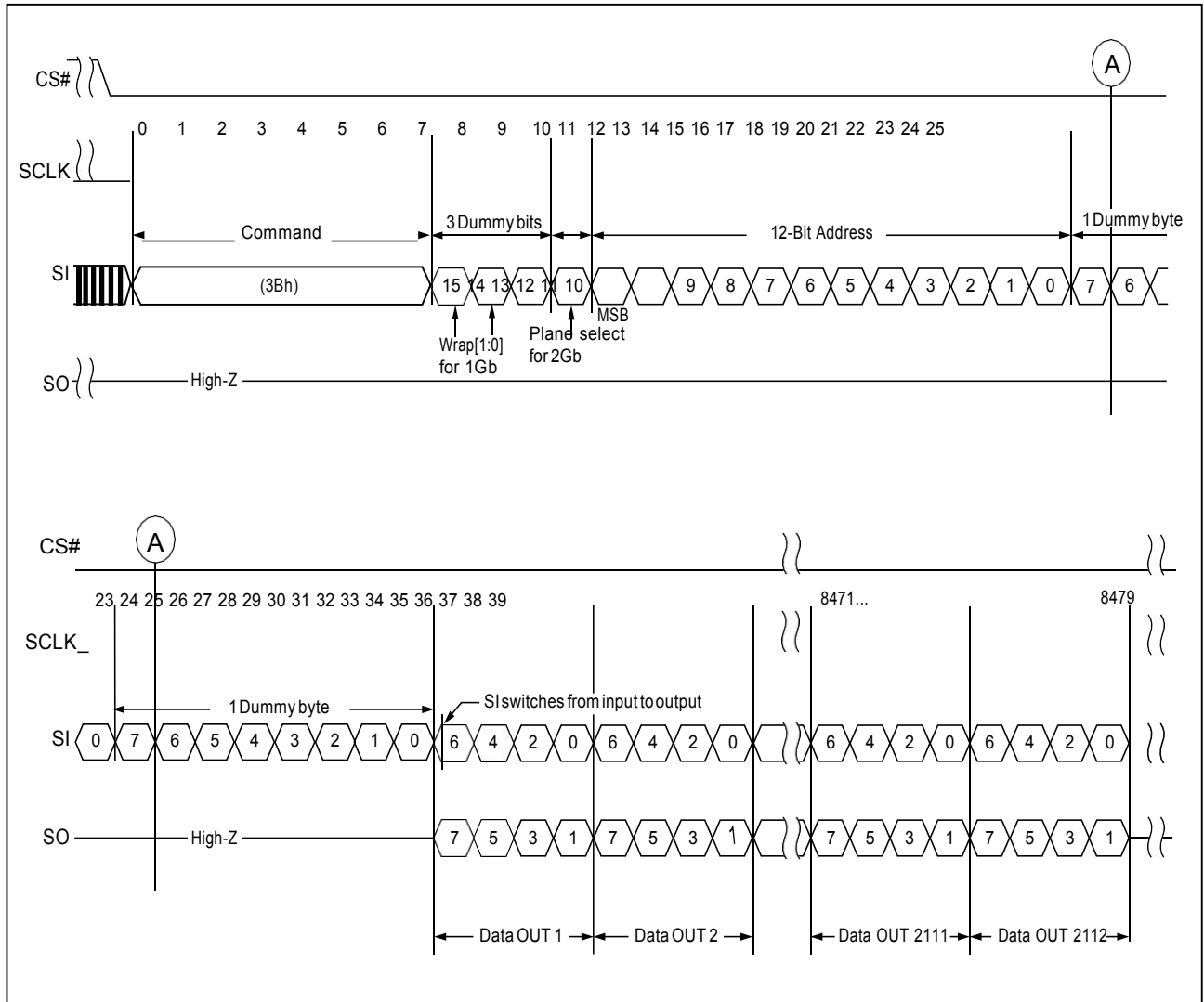
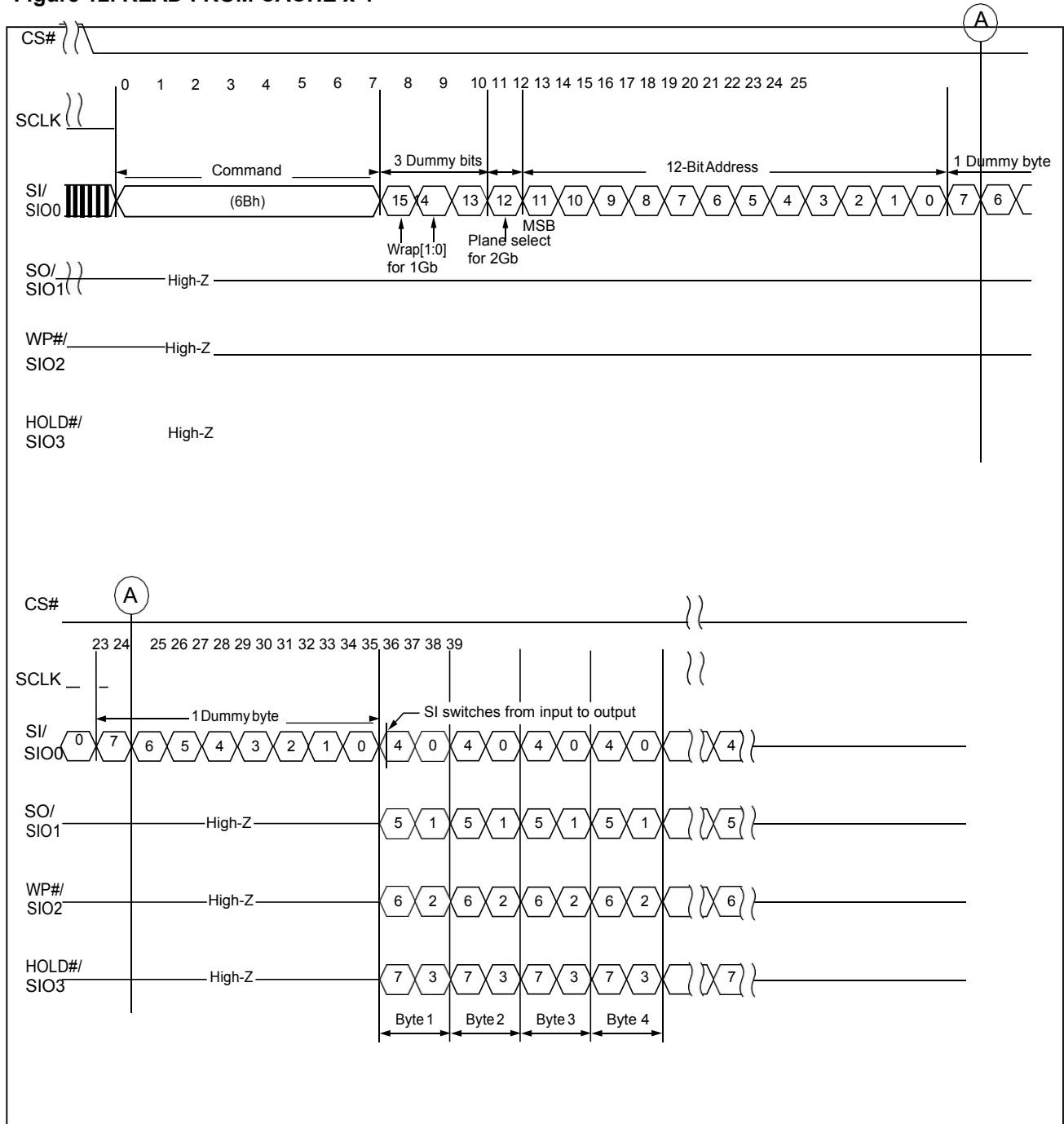

Figure 12. READ FROM CACHE x 4



8-3-3. Page Read Cache Sequential (31h) / Page Read Cache End (3Fh) - For 1G Only

The page read cache sequential operation is for throughput enhancement by using the internal cache buffer. It allows the consecutive pages to be read-out without giving next page address, which reduces the latency time from t_{RD} to t_{RCBSY} between pages or blocks. While the data is read out on one page, the data of next page can be read into the cache buffer.

After writing the 13h command and giving the 24-bit address, the device will have a period of time (t_{RD}) being busy after the CS# goes high. The 0Fh (GET FEATURE) may be used to poll the operation status. After the status of successfully completed, following the cache read sequential (31h) command being sent to NAND device; the NAND device will be at a busy time of t_{RCBSY} for the next page data transferring to cache. And then following the cache read command (03h/0Bh/3Bh/6Bh) may get the prior page data output from cache at the same time.

To confirm the last page to be read-out during the cache read sequential operation, a 3Fh command is needed to replace the 31h command prior to the last data-out.

The PAGE READ CACHE SEQUENTIAL command is also valid for the consecutive page cross block.

Figure 13. Page Read Cache Sequential (31h)

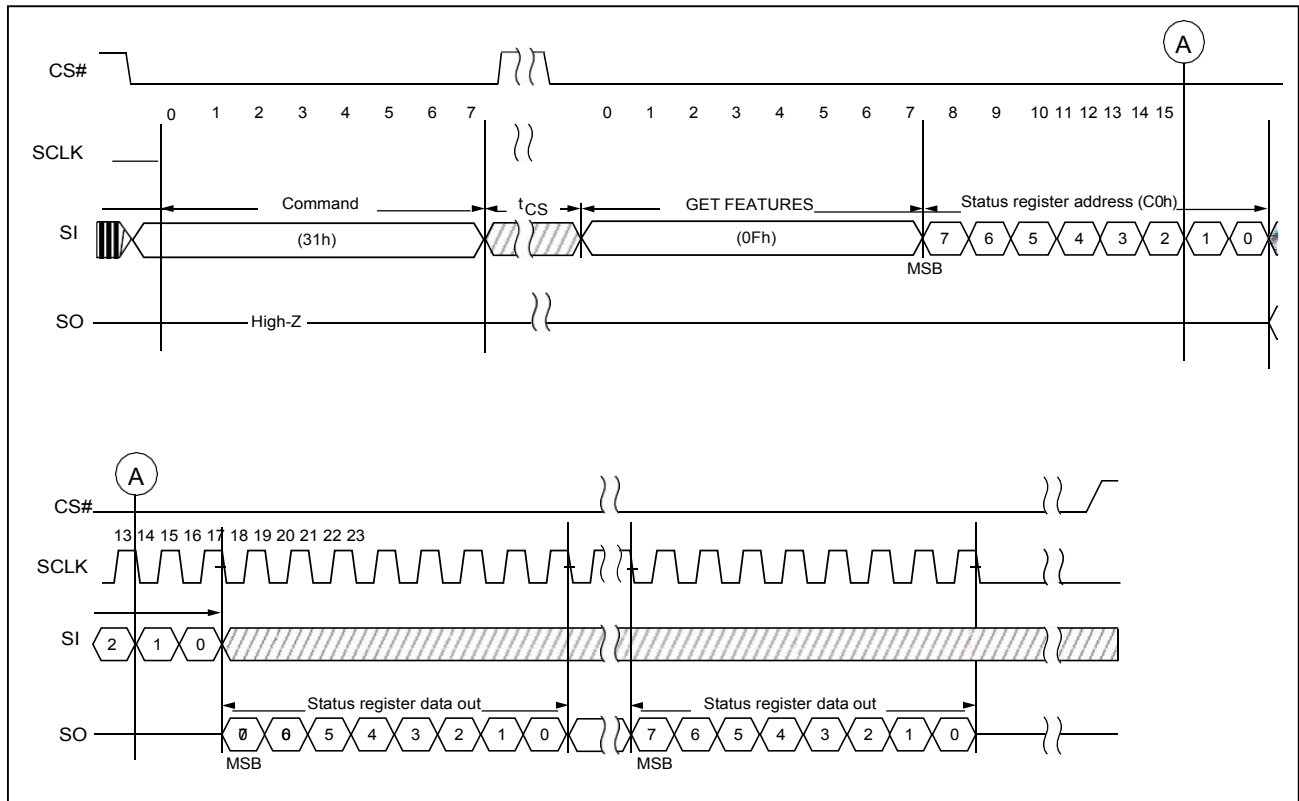

Figure 14. Page Read Cache End (3Fh)

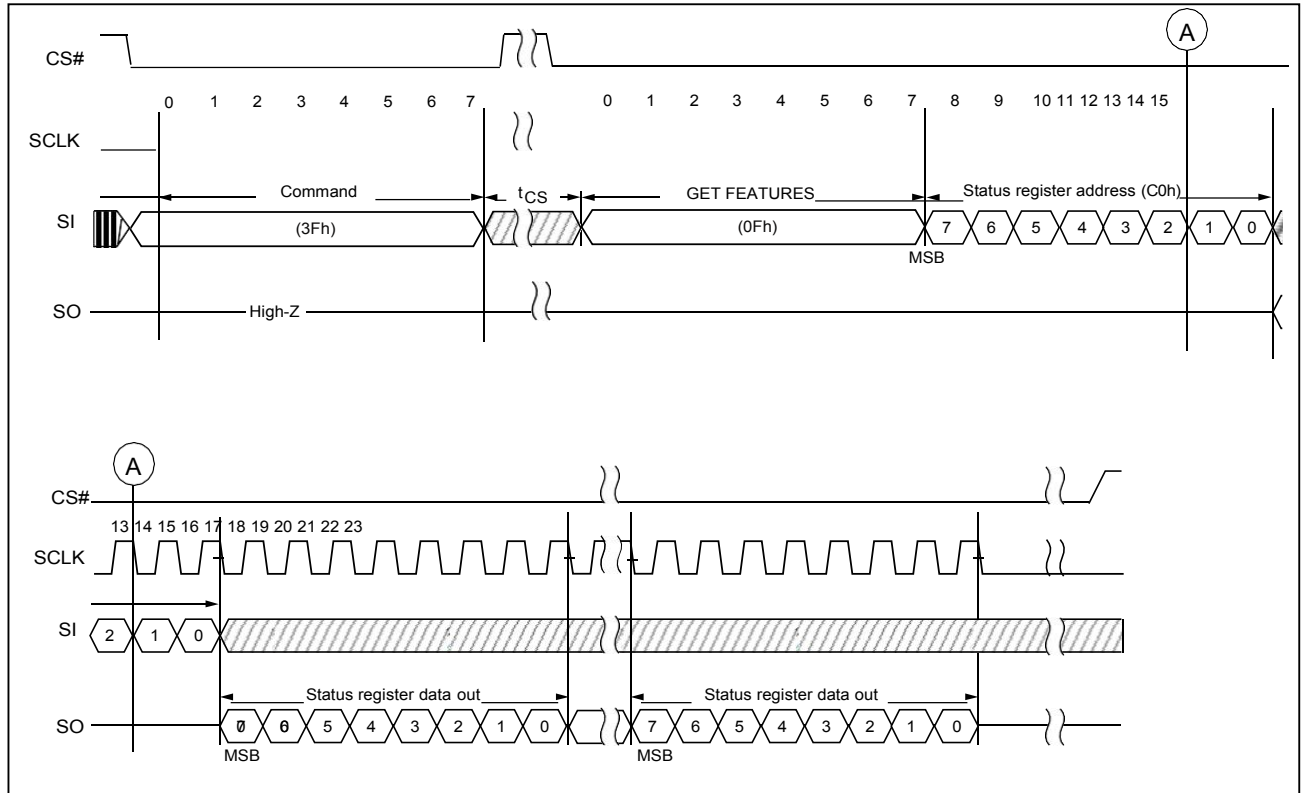
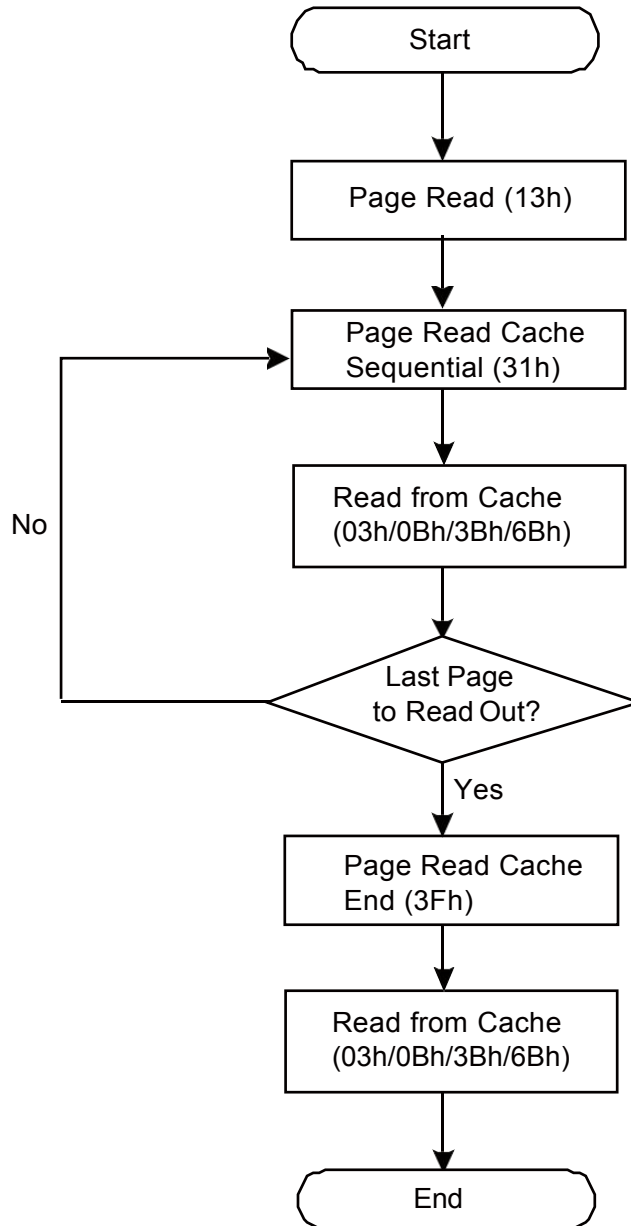

Figure 15. Page Read Cache Flow



8-3-4. READ ID (9Fh)

The READ ID command is shown as the table below.

Table 4. READ ID Table

Byte	Description	I/O7	I/O6	I/O5	I/O4	I/O3	I/O2	I/O1	I/O0	Value
Byte 0	Manufacturer ID (Macronix)	1	1	0	0	0	0	1	0	C2h
Byte 1	Device ID (Serial NAND)	0	0	0	1	0	0	1	0	12h (1Gb)
		0	0	1	0	0	0	1	0	22h (2Gb)

Figure 16. READ ID (9Fh) Timing

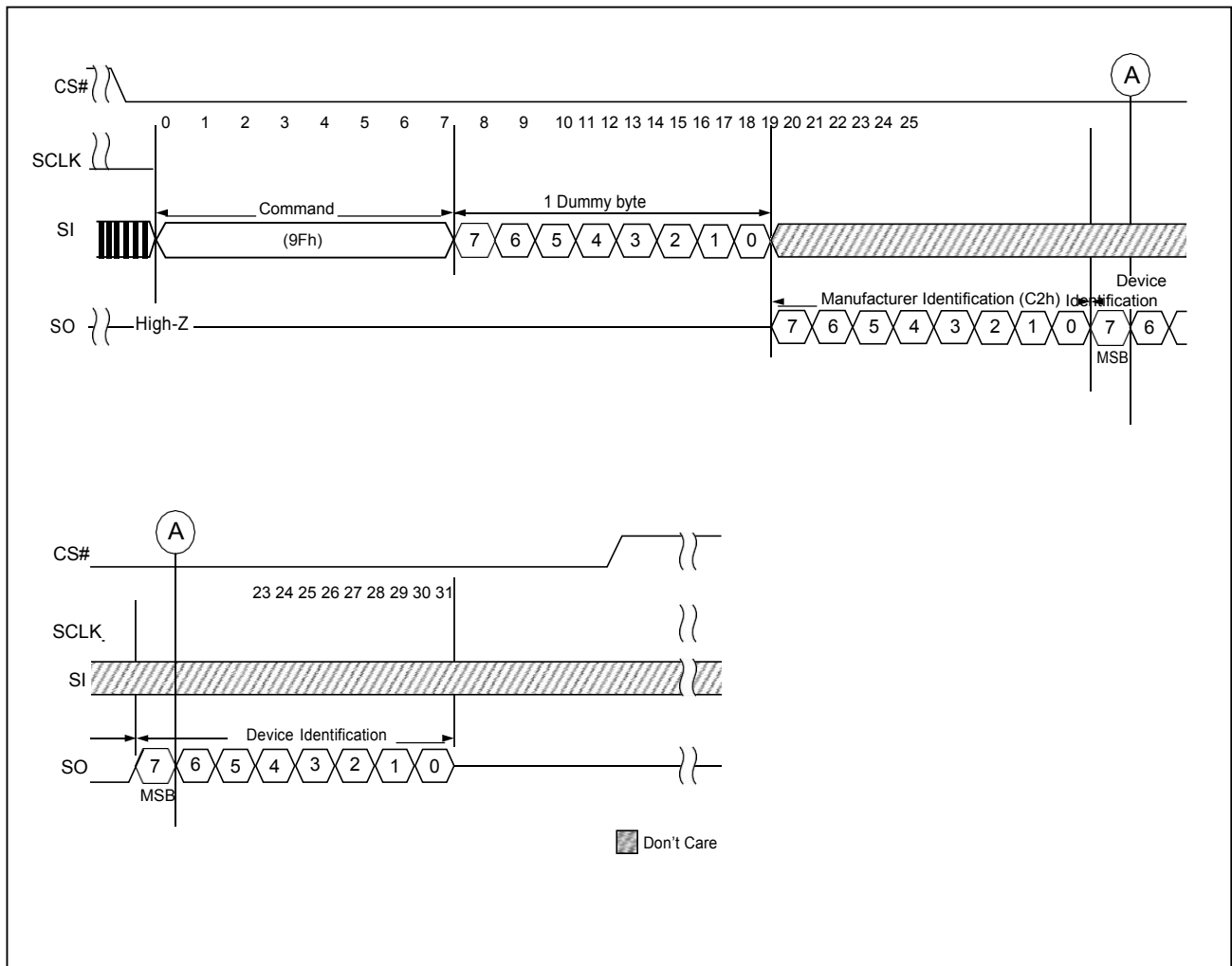

8-4. Parameter Page

The parameter page is accessed by the following command flows:

Issue 1Fh (SET FEATURE) command with Secure OTP enable and ECC disabled (B0h for address & 40h for data) → Issue 13h (PAGE READ) with 01h address, issue 0Fh (GET FEATURE) with C0h feature address to poll the status of read completion. → Issue 03h (READ FROM CACHE) with address A[11:0]=000h and read data → Issue 1Fh (SET FEATURE) with feature address B0h to disable Secure OTP feature (data byte = 10h or 00h) [exit parameter page read].

8-6. Internal ECC Status Read (For 1Gb only)

Besides the Get Feature(with feature address of C0h) may collect the internal ECC status; the 7Ch command may read out more status of internal ECC, such as 1-bit error, 2-bit error, 3-bit error, or 4-bit error by ECCSR[3:0] which Get Feature (with C0h address) cannot distinguish it. Please refer to the "**Table 6-1. The ECCSR (Internal ECC Status Register) Bits**" & "**Table 6-2. The Definition of Internal ECC Status**" about the ECCSR definition. The ECC Status Register reports the highest bit error correction among the four segments of a page. For example, if Segment 1 had a 1-bit error corrected, Segment 2 had no bit error, Segment 3 had a 2-bit error corrected, and Segment 4 had no bit error, then the ECC register would report that a 2-bit error was corrected. The register is updated after the completion of the Page Read Command (13h) The Reset Command (FFh) will clear the register to 00h.

Table 6-1. The ECCSR (Internal ECC Status Register) Bits

bit 7	bit 6	bit 5	bit 4	bit 3	bit 2	bit 1	bit 0
Reserved	Reserved	Reserved	Reserved	ECCSR[3]	ECCSR[2]	ECCSR[1]	ECCSR[0]

Table 6-2. The Definition of Internal ECC Status

ECCSR[3:0]	ECC Status
0000	No bit error
0001	1-bit error corrected
0010	2-bit error corrected
0011	3-bit error corrected
0100	4-bit error corrected
1111	Uncorrectable

Each Page has four 528-Byte ECC segments and each 528-Byte segment consists of 512 Bytes from the Data Area and its associated 16 Bytes from the Spare Area.

Figure 17. The Page Structure and Internal ECC Segments

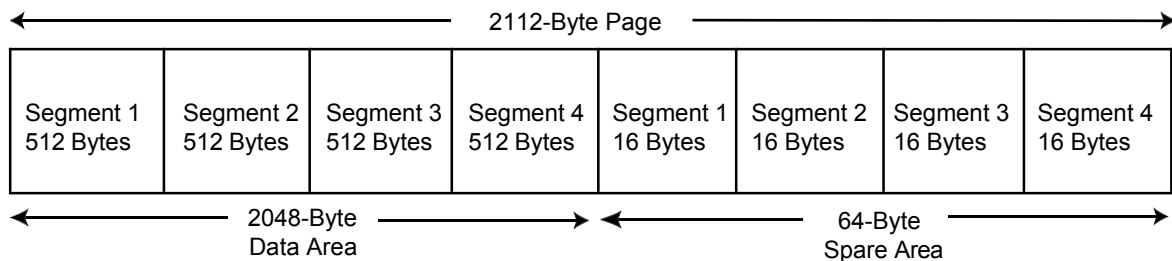

Operation sequence: Command (7Ch)→Dummy Byte (xxh) →Read ECC Status Register

Figure 18. The Sequence of Internal ECC Status Read

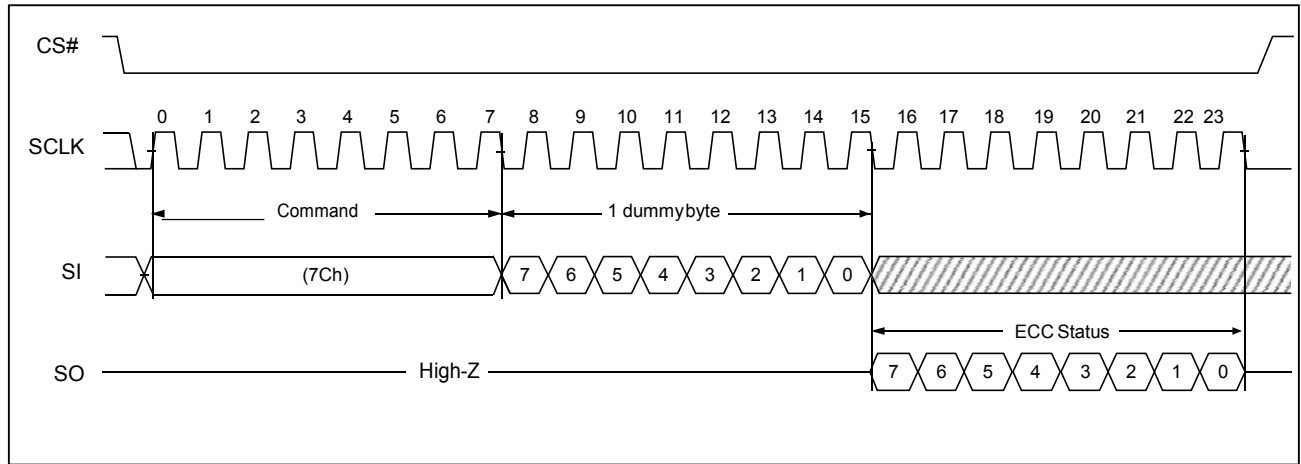

8-7. Program Operations

8-7-1. PAGE PROGRAM

With following operation sequences, the PAGE PROGRAM operation programs the page from byte 1 to byte 2112.

WRITE ENABLE (06h) → PROGRAM LOAD (02h) → PROGRAM LOAD RANDOM DATA (84h) if needed → PROGRAM EXECUTE (10h) → GET FEATUR from command to read status (0Fh).

WEL bit is set with the WRITE ENABLE (06h) issued. The program operation will be ignored if 06h command not issued. In a single page, four partial page programs are allowed. Exceeded bytes (Page address is larger than 2112) for "PROGRAM LOAD" or "PROGRAM LOAD RANDOM DATA", the exceeding bytes will be ignored. When CS goes high, the "PROGRAM LOAD" or "PROGRAM LOAD RANDOM DATA" operation" terminates. Please note the figure below for PROGRAM LOAD.

After PROGRAM LOAD is done, the programming of data should be as following steps: issue 10h (PROGRAM EXECUTE) with 1byte command code, 24 bits address → code programming to memory and busy for tPROG → Program complete.

During programming, status to be polled by the status register.

Operation shows in the Figure below.

Figure 19. PROGRAM LOAD (02h) Timing

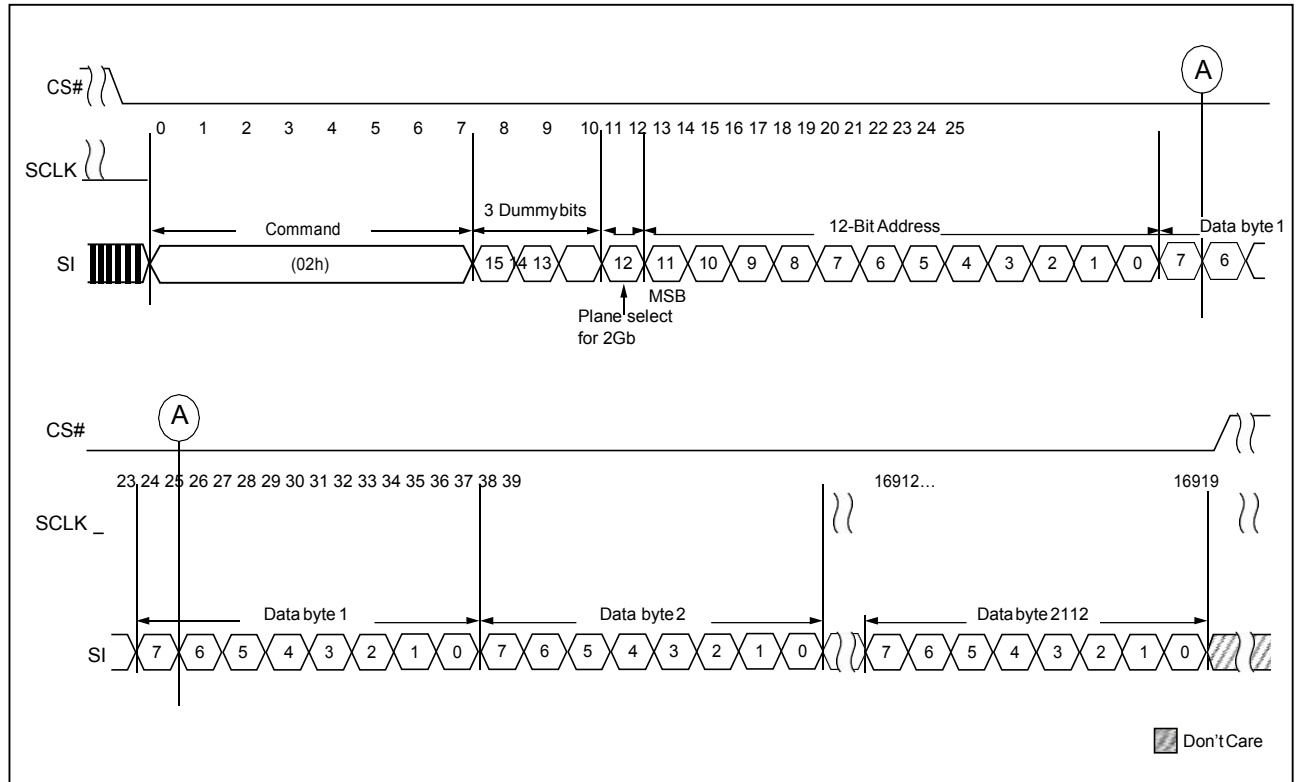
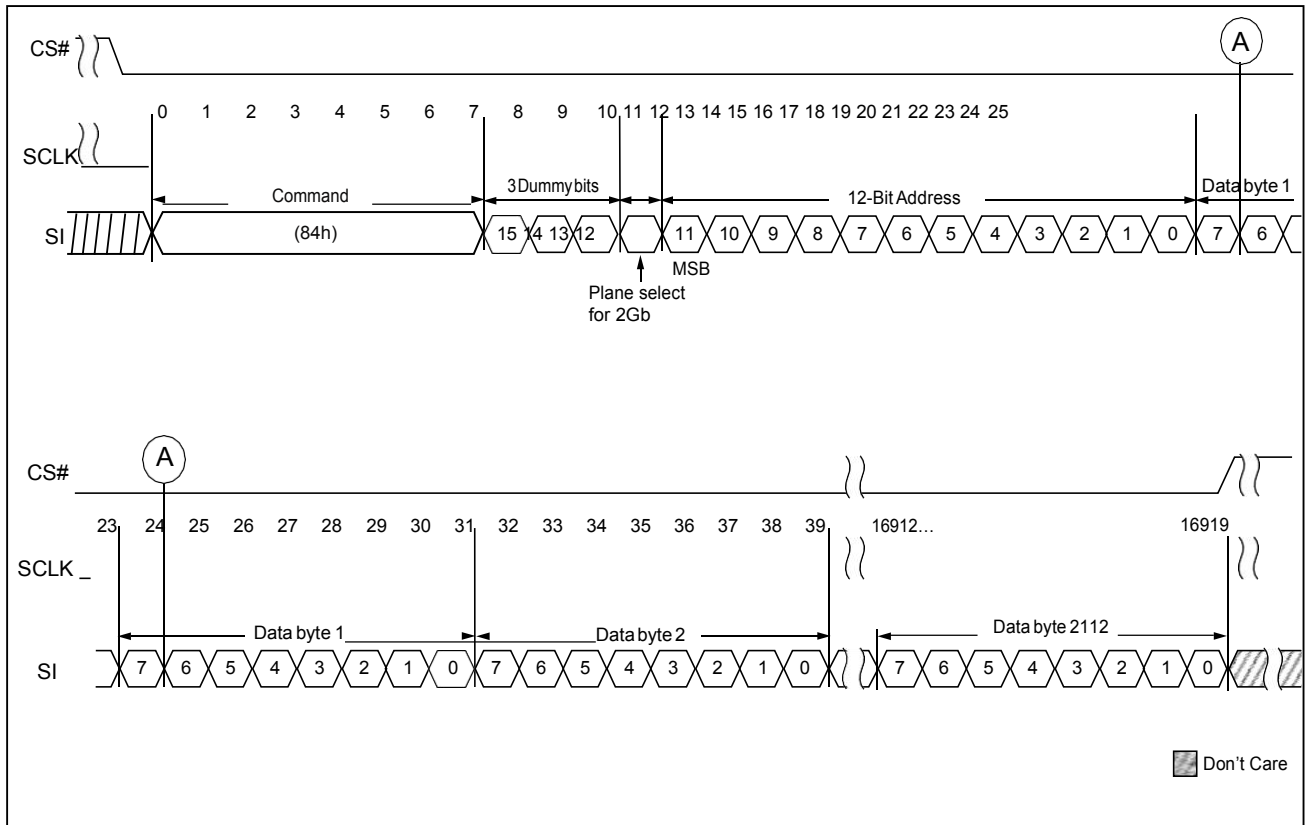

Figure 20. PROGRAM LOAD RANDOM DATA (84h) Timing



8-7-2. QUAD IO PAGE PROGRAM

QUAD IO PAGE PROGRAM conducts the 2Kbyte program with 4 I/O mode. The steps are: WRITE ENABLE (06h) → PROGRAM LOAD X4 (32h) → PROGRAM LOAD RANDOM DATA (34h) if needed → PROGRAM EXECUTE (10h) → Poll status by issuing GET FEATURE (0Fh).

Figure 21. PROGRAM LOAD X4 (32h) Timing

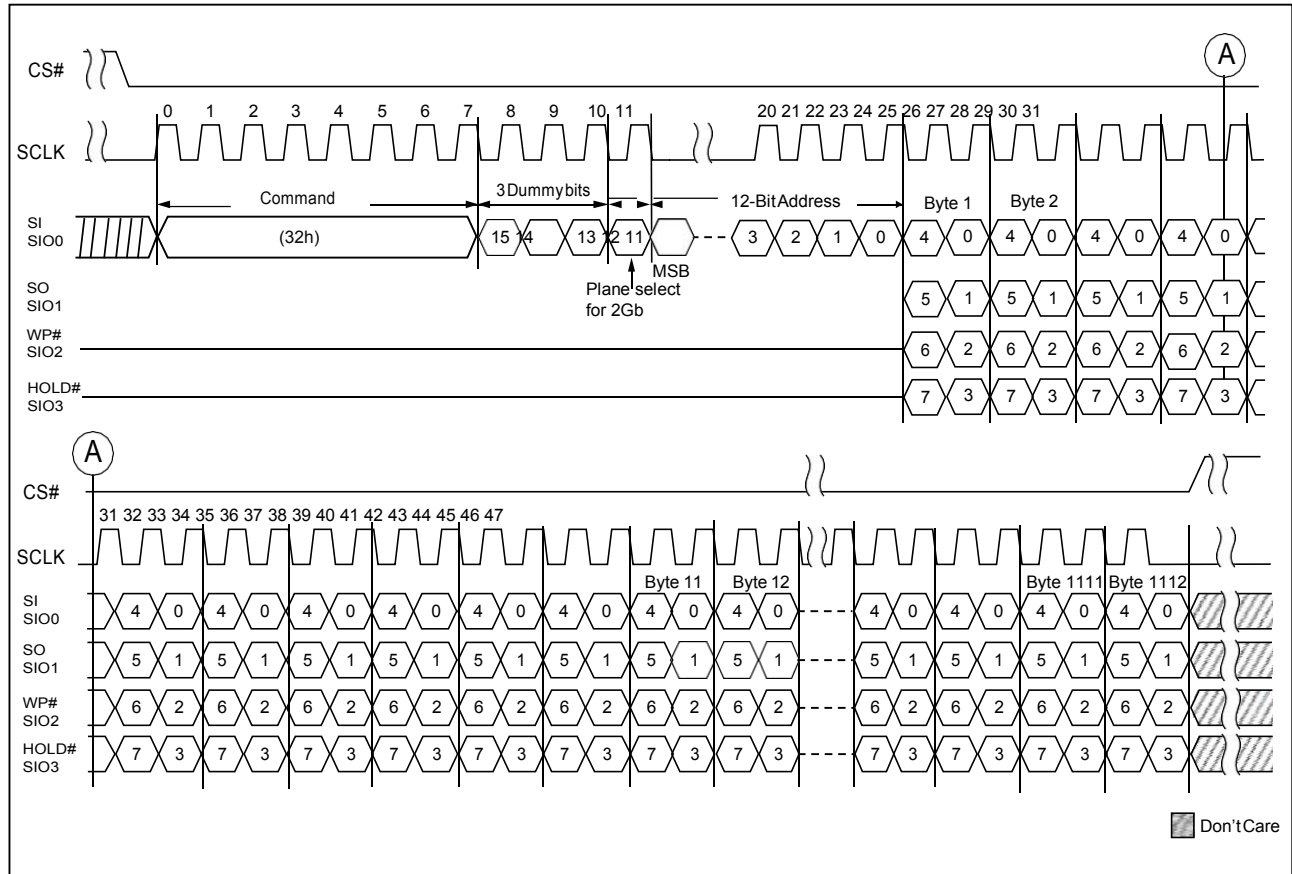

Figure 22. QUAD IO PROGRAM RANDOM INPUT (34h) Timing

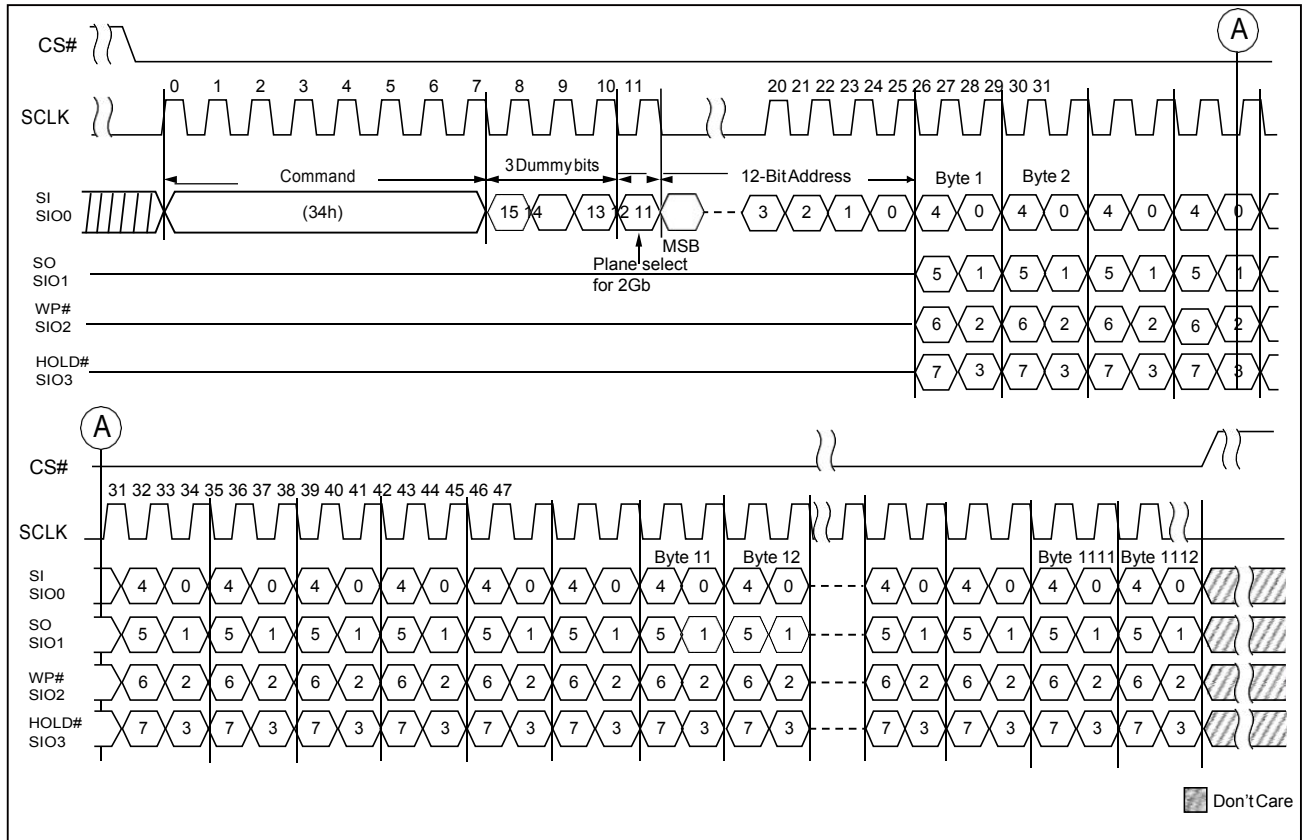
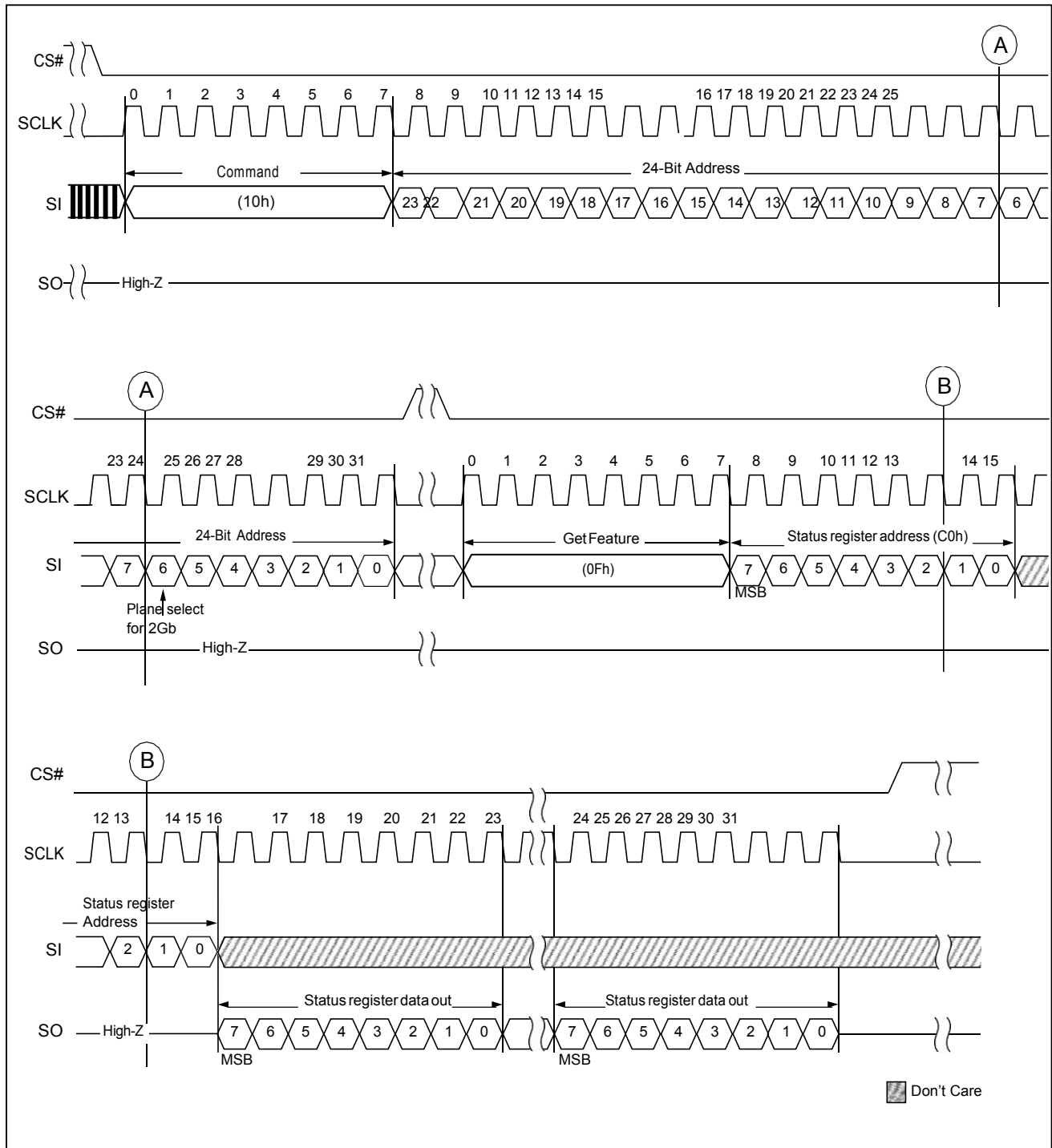

Figure 23. PROGRAM EXECUTE (10h) Timing



9. BLOCK OPERATIONS

9-1. Block Erase (D8h)

The Block Erase (D8h) instruction is for erasing the data of the chosen block to be "1". The instruction is used for a block of 128K-byte erase operation. A Write Enable (WREN) instruction be executed to set the Write Enable Latch (WEL) bit before sending the Block Erase (D8h). Any address of the block is a valid address for Block Erase (D8h) instruction. The CS# must go high exactly at the byte boundary (the least significant bit of address byte been latched-in); otherwise, the instruction will be rejected and not executed. Finally, a Get Feature(0Fh) instruction to check the status is necessary.

The sequence of issuing Block Erase instruction is: CS# goes low→ sending Block Erase instruction code→ 24-bit address on SI→CS# goes high.

The self-timed Block Erase Cycle time (tBE) is initiated as soon as Chip Select (CS#) goes high. The Get Feature (0Fh) instruction with Address (C0h) may check the status of the operation during the Block Erase cycle is in progress (please refer to the Get Feature waveform and table of Feature Setting). The OIP bit is "1" during the tBE timing, and is cleared to "0" when Block Erase Cycle is completed, and the Write Enable Latch (WEL) bit is cleared.

Figure 24. Block Erase (BE) Sequence

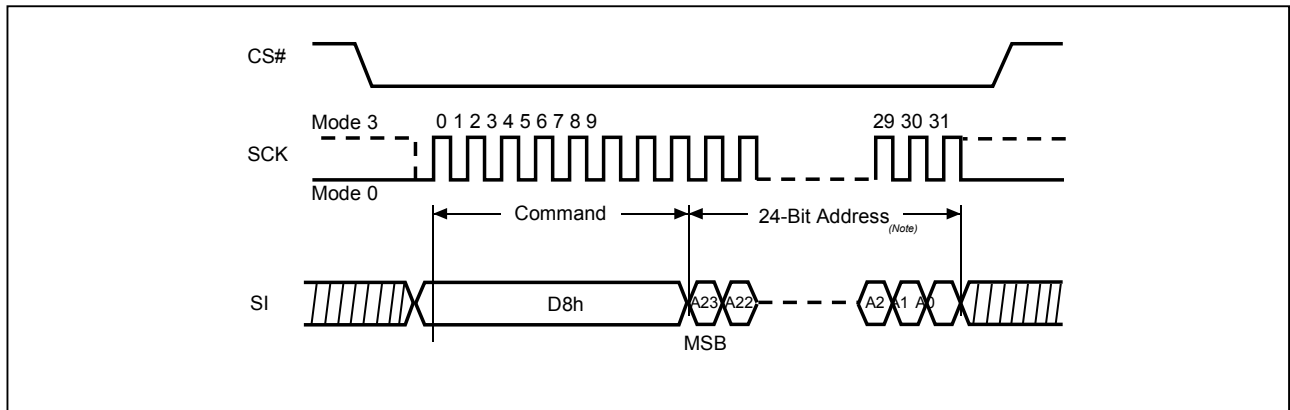

Note: The 24-bit Address includes: 17-bit row address and 7-bit dummy (for 2Gb), or 16-bit row address and 8-bit dummy (for 1Gb).

10. Feature Register

Feature register defines various register's definitions (Block Protection, Secure OTP, Status register). The definition of each register is defined in "**Table 7-1. Definition of Protection Bits (BPx) (For 2Gb)**" and "**Table 7-2. Definition of Protection Bits (For 1Gb)**":

10-1. Block Protection Feature

The Block Protection feature includes three block protection bits (BPx), Block Protection Register Write Disable (BPRWD). For 1Gb, there are three more feature bits, including Inverse bit (INVERT), complement bit (COMPLEMENTARY) and Solid Protection Bit (SP).

Soft Protection Mode (SPM)

The SPM uses the BPx bits, INVERT, and COMPLEMENTARY bits to allow part of memory to be protected as read only. The protected area definition is shown as "**Table 7-1. Definition of Protection Bits (BPx) (For 2Gb)**" and "**Table 7-2. Definition of Protection Bits (For 1Gb)**", the protected areas are more flexible which may protect various area by setting value of BP0-BP3 bits. These are volatile bits and can be modified by set feature command.

Note: INVERT, and COMPLEMENTARY bits are for 1Gb only.

After power-up, the chip is in protection state, that is, the feature bits BPx is 1, all other bits (BPRWD, INVERT, COMPLEMENTARY and SP) are 0. The Set feature instruction (1Fh) with feature address (A0h) may change the value of the block protection bits and un-protect whole chip or a certain area for further program/erase operation. For example, after the power-on, the whole chip is protected from program/erase operation, the top 1/64 area may be un-protected by using the Set feature instruction (1Fh) with the feature address (A0h) to change the values of BP2 and BP1 from "1" to "0" as "**Table 7-1. Definition of Protection Bits (BPx) (For 2Gb)**" and "**Table 7-2. Definition of Protection Bits (For 1Gb)**" of "Block protection register bits".

Hardware Protection Mode (HPM) & Solid Protection Mode (SDPM)

Under the Hardware Protection mode and Solid Protection Mode, the (BPx, INVERT, COMPLEMENTARY) bits can not be changed.

Hardware Protection Mode: The device enters HPM if BPRWD bits is set to 1 and WP#/SIO2 is driven to 0.

Note 1: The 1Gb HPM also requires SP bit to be 0 state (SP bit is for 1Gb only).

Note 2: The Quad mode is not supported in HPM.

Solid Protection Mode: If SP bit is set to 1, the device enters SDPM (Only for 1Gb). After that, the selected block is solid protected and can not be un-protected until next power cycle.

Table 7-1. Definition of Protection Bits (BPx) (For 2Gb)

Block Protection Register Bits			Protected Area
BP2	BP1	BP0	
0	0	0	None - all unprotected
0	0	1	Top 1/64 protected
0	1	0	Top 1/32 protected
0	1	1	Top 1/16 protected
1	0	0	Top 1/8 protected
1	0	1	Top 1/4 protected
1	1	0	Top 1/2 protected
1	1	1	All protected (default)

Note: Block #0 is at bottom portion.

Table 7-2. Definition of Protection Bits (For 1Gb)

BP2	BP1	BP0	Invert	Complementary	Protection Area
0	0	0	x	x	all unlocked
0	0	1	0	0	upper 1/64 locked
0	1	0	0	0	upper 1/32 locked
0	1	1	0	0	upper 1/16 locked
1	0	0	0	0	upper 1/8 locked
1	0	1	0	0	upper 1/4 locked
1	1	0	0	0	upper 1/2 locked
1	1	1	x	x	all locked (default)
0	0	1	1	0	lower 1/64 locked
0	1	0	1	0	lower 1/32 locked
0	1	1	1	0	lower 1/16 locked
1	0	0	1	0	lower 1/8 locked
1	0	1	1	0	lower 1/4 locked
1	1	0	1	0	lower 1/2 locked
0	0	1	0	1	lower 63/64 locked
0	1	0	0	1	lower 31/32 locked
0	1	1	0	1	lower 15/16 locked
1	0	0	0	1	lower 7/8 locked
1	0	1	0	1	lower 3/4 locked
1	1	0	0	1	block 0
0	0	1	1	1	upper 63/64 locked
0	1	0	1	1	upper 31/32 locked
0	1	1	1	1	upper 15/16 locked
1	0	0	1	1	upper 7/8 locked
1	0	1	1	1	upper 3/4 locked
1	1	0	1	1	block0

Note: Block #0 is at lower portion.

10-2. Secure OTP (One-Time-Programmable) Feature

There is an Secure OTP area which has 30 full pages (30 x 2112-byte) from page 02h to page 1Fh guarantee to be good for system device serial number storage or other fixed code storage. The Secure OTP area is a non-erasable and one-time-programmable area, which is default to "1" and allows partial page program to be "0", once the Secure OTP protection mode is set, the Secure OTP area becomes read-only and cannot be programmed again.

The Secure OTP operation is operated by the Set Feature instruction with feature address (B0h) to access the Secure OTP operation mode and Secure OTP protection mode.

To check the NAND device is ready or busy in the Secure OTP operation mode, the status register bit 0 (OIP bit) may report the status by Get Feature command operation.

To exit the Secure OTP operation or protect mode, it can be done by writing "0" to both Bit7 (Secure OTP protect bit) and bit6 (Secure OTP enable bit) for returning to the normal operation.

Secure OTP Read

1. Issuing the Set Feature instruction (1Fh)
2. Sending the Feature address (B0h) and set the "Secure OTP Enabled Bit" as "1".
3. Issuing normal Page Read command (13h)

Secure OTP Program (if the "Secure OTP Protection Bit" is "0") for

1. Issuing the Set Feature instruction (1Fh)
2. Sending the Feature address (B0h) and set the "Secure OTP Enabled Bit" as "1".
3. Issuing Page Program command (02h)
4. Issuing program execute command (10h)

Secure OTP Protection

1. Issuing the Set Feature instruction (1Fh)
2. Sending the Feature address (B0h) and set both the "Secure OTP Protection Bit" and "Secure OTP Enabled Bit" as "1".
3. Issuing program execute command (10h)

Table 8. Secure OTP States

Secure OTP Protection Bit ^{Note1}	Secure OTP Enabled Bit	State
0	0	Normal operation
0	1	Access the Secure OTP for reading or programming
1	0	Not applicable
1	1	Secure OTP Protection by using the Program Execution command (10h) ^{Note2}

Note 1. "Secure OTP protection bit" is non-volatile for 1G; whereas, which is volatile for 2G.

Note 2. Once the "Secure OTP Protection Bit" and "Secure OTP Enabled Bit" are set as "1", the secure OTP becomes read only.

10-3. Status Register

The MX35LFxGE4AB provides a status register that outputs the device status by writing a Get Feature command (0Fh) with the feature address (C0h), and then the IO pins output the status.

The Get Feature (0Fh) command with the feature address(C0h) will keep the device at the status read mode unless next valid command is issued. The resulting information is outlined in the table below.

Table 9. Status Register Bit Descriptions

SR Bit	Bit Name	Description
SR[0] (OIP)	Operation in progress	The bit value indicates whether the device is busy in operations of read/ program execute/ erase/ reset command. 1: Busy, 0: Ready
SR[1] (WEL)	Write enable latch	The bit value indicates whether the device is set to internal write enable latch. When WEL bit sets to 1, which means the internal write enable latch is set, and then the device can accept program/ erase/write status register instruction. 1: write enable, 0: not write enable The bit value will be cleared (as "0") by issuing Write Disable command(04h) or after the program/erase operation completion.
SR[2] (ERS_Fail)	Erase fail	The bit value shows the status of erase failure or if host erase any invalid address or protected area (including protected blocks or protected Secure OTP area). 0: Passed, 1: Failed The bit value will be cleared (as "0") by RESET command or at the beginning of the block erase command operation.
SR[3] (PGM_Fail)	Program fail	The bit value shows the status of program failure or if host program any invalid address or protected area (including protected blocks or protected Secure OTP area). 0: Passed, 1: Failed The bit value will be cleared (as "0") by RESET command or during the program execute command operation.
SR[5:4] (ECC_S1, ECC_S0)	ECC Status	The bit shows the status of ECC as below: 00b = 0 bit error 01b = 1 to 4 bits error corrected. 10b = More than 4-bit error not corrected. 11b = Reserved The value of ECC_Sx (S1:S0) bits will be clear as "00b" by Reset command or at the start of the Read operation. After a valid Read operation completion, the bit will be updated to reflect the ECC status of the current valid Read operation. The ECC_Sx (S1:S0) value reflects the ECC status of the content of the page 0 of block 0 after a power-on reset. If the internal ECC is disabled by the Set feature command, the ECC_Sx(S1:S0) are invalid.
SR[6] (CRBSY)	Cache Status Bit	The bit value indicates whether the internal cache is busy in Page Read Cache Sequential command. 1: Busy- internal cache is busy on data transfer 0: Ready- device is ready for cache data out
SR[7]	Reserved	

Note: SR[6] is reserved for 2Gb.

11. SOFTWARE ALGORITHM

11-1. Invalid Blocks (Bad Blocks)

The bad blocks are included in the device while it gets shipped. During the time of using the device, the additional bad blocks might be increasing; therefore, it is necessary to check the bad block marks and avoid using the bad blocks. Furthermore, please read out the bad block information before any erase operation since the bad block marks may be cleared by any erase operation.

Figure 25. Bad Blocks

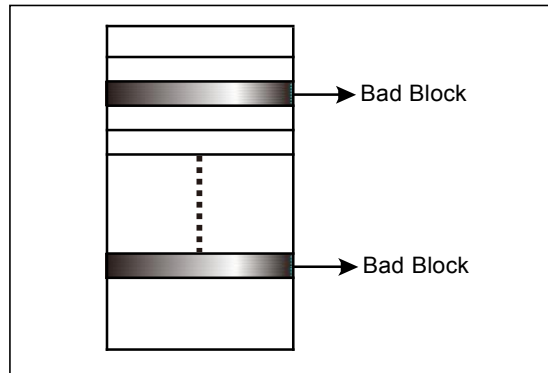

While the device is shipped, the value of all data bytes of the good blocks are FFh. The 1st byte of the 1st and 2nd page in the spare area for bad block will be 00h. The erase operation at the bad blocks is not recommended.

After the device is installed in the system, the bad block checking is recommended. "**Figure 23. Bad Block Test Flow**" shows the brief test flow by the system software managing the bad blocks while the bad blocks were found. When a block gets damaged, it should not be used any more.

Due to the blocks are isolated from bit-line by the selected gate, the performance of good blocks will not be impacted by bad ones.

Table 10. Valid Blocks

	Density	Min.	Typ.	Max.	Unit	Remark
Valid (Good) Block Number	1Gb	1004		1024	Block	Block 0 is guaranteed to be good (with ECC).
	2Gb	2008		2048	Block	

11-2. Bad Block Test Flow

Although the initial bad blocks are marked by the flash vendor, they could be inadvertently erased and destroyed by a user that does not pay attention to them. To prevent this from occurring, it is necessary to always know where any bad blocks are located. Continually checking for bad block markers during normal use would be very time consuming, so it is highly recommended to initially locate all bad blocks and build a bad block table and reference it during normal NAND flash use. This will prevent having the initial bad block markers erased by an unexpected program or erase operation. Failure to keep track of bad blocks can be fatal for the application. For example, if boot code is programmed into a bad block, a boot up failure may occur. "Figure 26. Bad Block Test Flow" shows the recommended flow for creating a bad block table.

Figure 26. Bad Block Test Flow

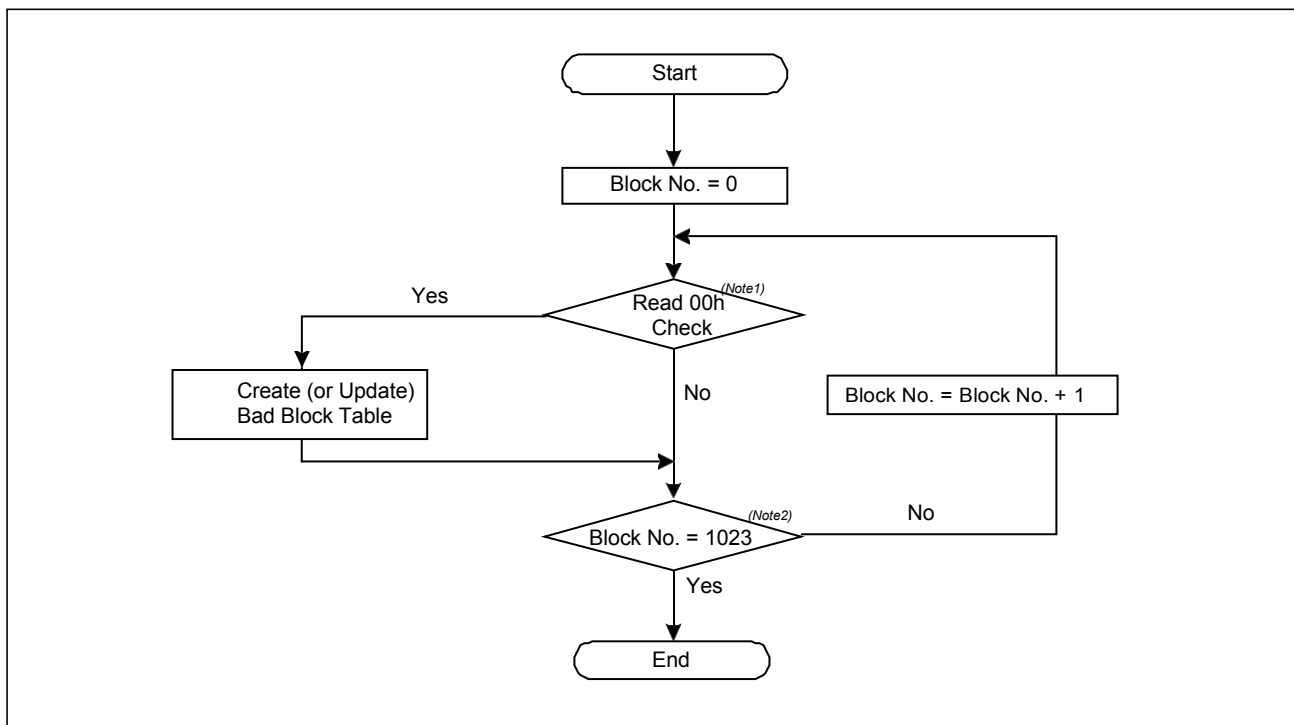

Note 1: Read 00h check is at the 1st byte of the 1st and 2nd pages of the block spare area.

Note 2: The Block No. = 1023 for 1Gb, 2047 for 2Gb.

11-3. Failure Phenomena for Read/Program/Erase Operations

The device may fail during a Read, Program or Erase operation. The following possible failure modes should be considered when implementing a highly reliable system:

Table 11. Failure Modes

Failure Mode	Detection and Countermeasure	Sequence
Erase Failure	Status Read after Erase	Block Replacement
Programming Failure	Status Read after Program	Block Replacement
Read Failure (Note)	Read Failure	ECC

Note: If the internal ECC is enabled, the internal ECC will handle the Read failure.

11-3-1. Internal ECC Enabled/Disabled

The internal ECC logic may detect 5-bit error and correct 4-bit error. The default state of the internal ECC is enabled. To enable/disable the internal ECC, it is operated by the Set Feature operation to enable internal ECC or disable the internal ECC, and then check the internal ECC state by Get Feature operation.

The internal ECC is enabled by using Set Feature command (1Fh) and followed by feature address (B0h) and then set Bit4(ECC enabled) as "1". To disable the internal ECC can be done by using the Set Feature command (1Fh) and followed by the feature address (B0h) and then set Bit4(ECC enabled) as "0".

When the internal ECC is enabled, after the data transfer time (tRD_ECC) is completed, a Status Read operation is required to check any uncorrectable read error happened. Please refer to "**Table 9. Status Register Bit Descriptions**".

The constraint of the internal ECC enabled operation:

- The ECC protection coverage: please refer to "**Table 12. The Distribution of ECC Segment and Spare Area**". Only the grey areas are under internal ECC protection when the internal ECC is enabled.
- The number of partial-page program is not 4 in an ECC segment, the user need to program the main area (512B)+Metadata1(12B) at one program time, so the ECC parity code can be calculated properly and stored in the additional hidden spare area.

Table 12. The Distribution of ECC Segment and Spare Area

Area	Main Area (0)	Main Area (1)	Main Area (2)	Main Area (3)	Spare(0)			Spare(1)			Spare(2)			Spare(3)		
					R1	M2	M1	R1	M2	M1	R1	M2	M1	R1	M2	M1
Addr. (Start)	000h	200h	400h	600h	800h	802h	804h	810h	812h	814h	820h	822h	824h	830h	832h	834h
Addr. (End)	1FFh	3FFh	5FFh	7FFh	801h	803h	80Fh	811h	813h	81Fh	821h	823h	82Fh	831h	833h	83Fh
Size	512(B)	512(B)	512(B)	512(B)	2(B)	2(B)	12(B)	2(B)	2(B)	12(B)	2(B)	2(B)	12(B)	2(B)	2(B)	12(B)

Notes:

R1: Reserved

M2: Metadata 2

M1: Metadata 1

Grey area: Under ECC protection

12. DEVICE POWER-UP

12-1. Power-up

After the Chip reaches the power on level, the internal power on reset sequence will be triggered. During the internal power on reset period, no any external command is accepted. The device can be fully accessible when VCC reaches the power-on level and wait 1ms.

During the power on and power off sequence, it is necessary to keep the WP# = Low for internal data protection.

Figure 27. Power On Sequence

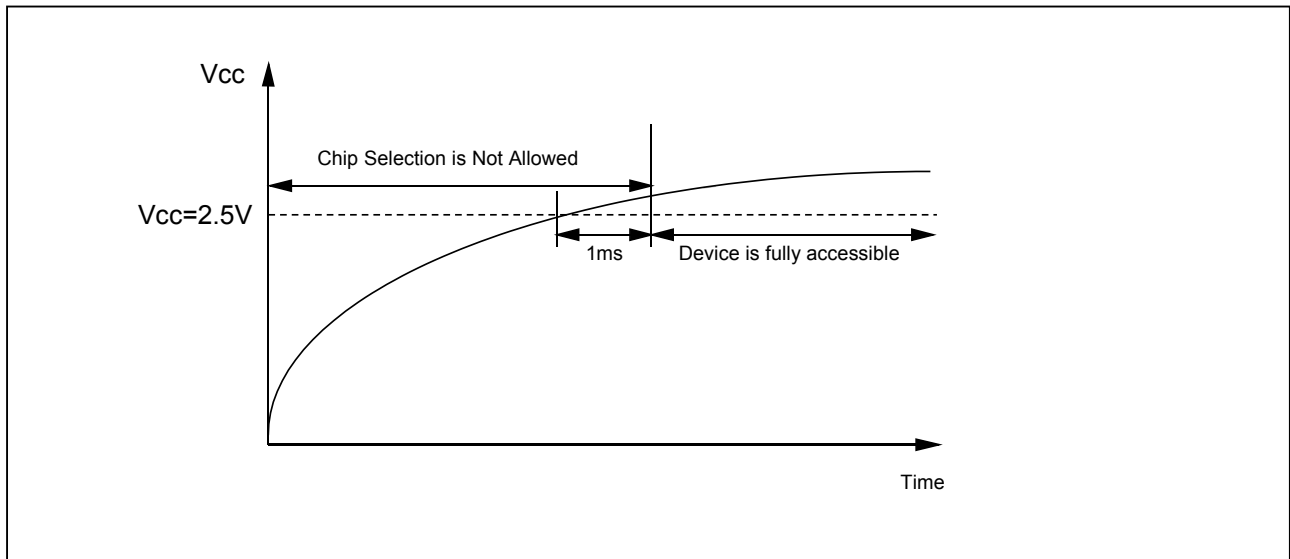

13. PARAMETERS

13-1. ABSOLUTE MAXIMUM RATINGS

Temperature under Bias	-50°C to +125°C
Storage temperature	-65°C to +150°C
All input voltages with respect to ground (Note 2)	-0.6V to 4.6V
VCC supply voltage with respect to ground (Note 2)	-0.6V to 4.6V
ESD protection	>2000V

Notes:

1. The reliability of device may be impaired by exposing to extreme maximum rating conditions for long range of time.
2. Permanent damage may be caused by the stresses higher than the "Absolute Maximum Ratings" listed.
3. During voltage transitions, all pins may overshoot V_{ss} to $-2.0V$ and V_{cc} to $+2.0V$ for periods up to 20ns, please refer to "Figure 28. Maximum Negative Overshoot Waveform" and "Figure 29. Maximum Positive Overshoot Waveform".

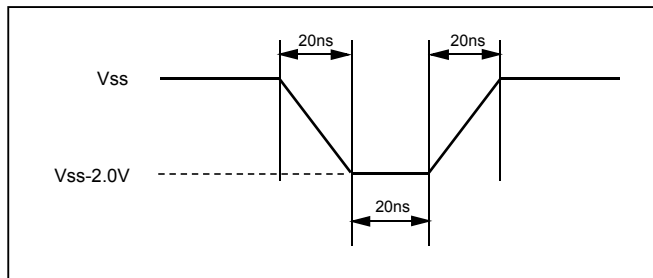
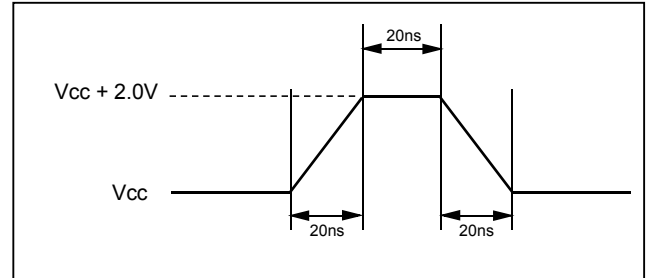
Figure 28. Maximum Negative Overshoot Waveform

Figure 29. Maximum Positive Overshoot Waveform

Table 13. AC Testing Conditions

Testing Conditions	Value	Unit
Input pulse level	0 to VCC	V
Output load capacitance	1TTL+CL(30)	pF
Input rising & falling time	5	ns
Input timing measurement reference levels	VCC/2	V
Output timing measurement reference levels	VCC/2	V

Table 14. Capacitance
 $T_A = +25^\circ\text{C}$, $F = 1\text{ MHz}$

Symbol	Parameter	Min.	Typ.	Max.	Units	Conditions
CIN	Input capacitance			6	pF	VIN = 0V
COUT	Output capacitance			8	pF	VOUT = 0V

Note: $C_{IN}/C_{OUT} = 10\text{pF}/10\text{pF}$ for 2Gb

Table 15. Operating Range

Temperature	VCC	Tolerance
-40°C to +85°C	+3.3V	2.7 - 3.6V

Table 16. DC Characteristics

Symbol	Parameter	Min.	Typical	Max.	Unit	Test Conditions
ILI	Input leakage current			+/- 10	uA	VIN= 0 to VCC Max.
ILO	Output leakage current			+/- 10	uA	VOUT= 0 to VCC Max.
ISB	VCC standby current (CMOS)		15	50	uA	VIN=VCC or GND, CS#=VCC
ICC1	VCC active current (Sequential Read)		20 ^{NOTE}	30	mA	f=104MHz
ICC2	VCC active current (Program)		20 ^{NOTE}	30	mA	
ICC3	VCC active current (Erase)		15	30	mA	
VIL	Input low level	-0.3		0.2VCC	V	
VIH	Input high level	0.8VCC		VCC + 0.3	V	
VOL	Output low voltage			0.2	V	IOL= -1mA
VOH	Output high voltage	VCC-0.2			V	IOH= -20uA

Note: ICC1/ICC2 typical value is 15mA for 1Gb.

Table 17. General Timing Characteristics

Symbol	Parameter	Min.	Max.	Unit
fC	Clock Frequency	-	104	MHz
tCHHH	HOLD# high hold time relative to SCLK	5	-	ns
tCHHL	HOLD# low hold time relative to SCLK	5	-	ns
tCS	Command disect time	100	-	ns
tCHSH	Chip select# hold time	4	-	ns
tSLCH	Chip select# setup time	4	-	ns
tSHCH	Chip select# non-active setup time	4	-	ns
tCHSL	Chip select# non-active hold time	4	-	ns
tDIS	Output disable time	-	20	ns
tHC	Hold# non-active setup time relative to SCLK	5	-	ns
tHD	Hold# setup time relative to SCLK	5	-	ns
tHDDAT	Data input hold time	3.5	-	ns
tHO	Output hold time	1	-	ns
tHZ	Hold to output High-Z	-	15	ns
tLZ	Hold to output low-Z	-	15	ns
tSUDAT	Data input setup time	3.5	-	ns
tV	Clock LOW to output Valid	-	8	ns
tWH	Clock HIGH time	4	-	ns
tWL	Clock LOW time	4	-	ns
tWPH	WP# hold time	100	-	ns
tWPS	WP# setup time	20	-	ns

Table 18. PROGRAM/READ/ERASE Characteristics

Symbol	Parameter	Min.	Typ.	Max.	Unit
tRD	Data transfer time from NAND Flash array to data register.		-	25	us
tRCBSY (For 1Gb)	Dummy busy time for data read sequential		3.5	25	us
tRD_ECC	Data transfer time from NAND Flash array to data register with internal ECC enabled		45	70	us
tRST	Device reset time (Read/ Program/ Erase)			5/10/500	us
tPROG	Page programming time		300	600	us
tPROG_ECC	Page programming time under internal ECC enabled		320	600	us
tERS	Block Erase Time		1	3.5	ms
NOP ^{NOTE}	Number of partial-page programming operation supported		-	4	cycle

Note: When internal ECC is enabled, the partial program cycle is limited to be one for each ECC unit, and do not exceed the four partial program cycles per page.

Figure 30. WP# Setup Timing and Hold Timing during SET FEATURE when BPRWD=1

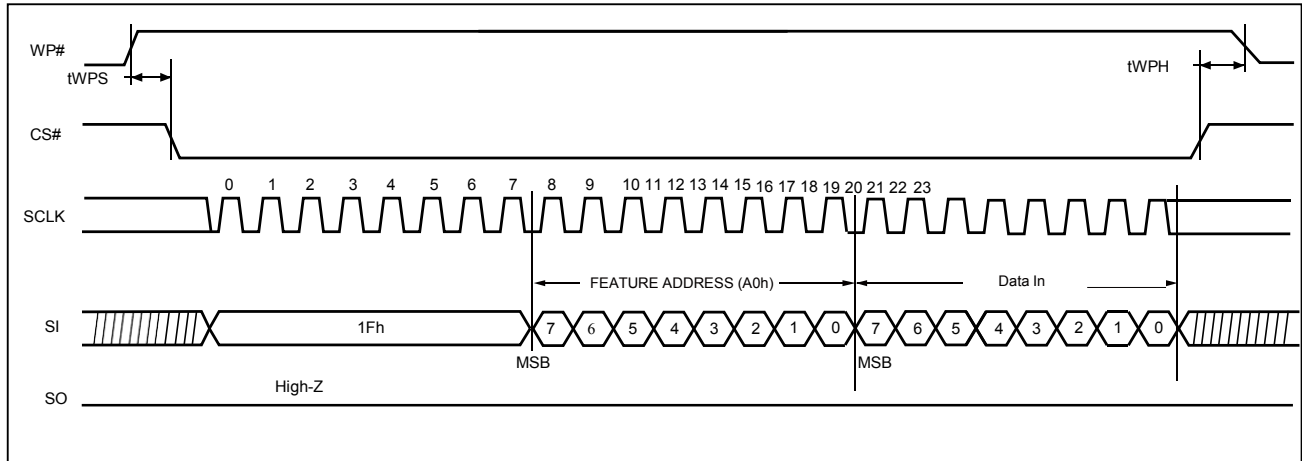

Figure 31. Serial Input Timing

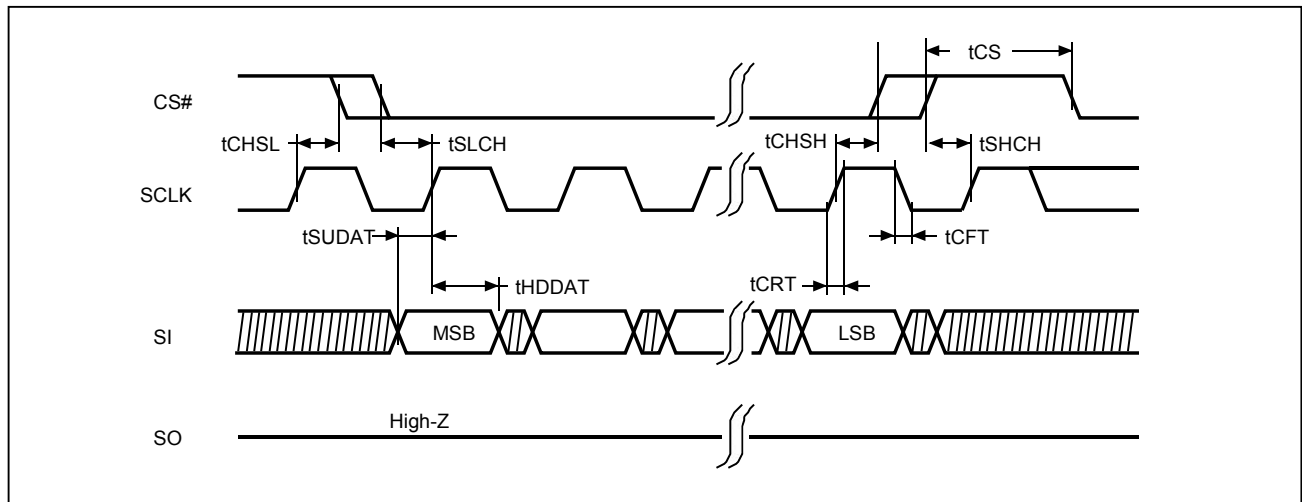

Figure 32. Serial Output Timing

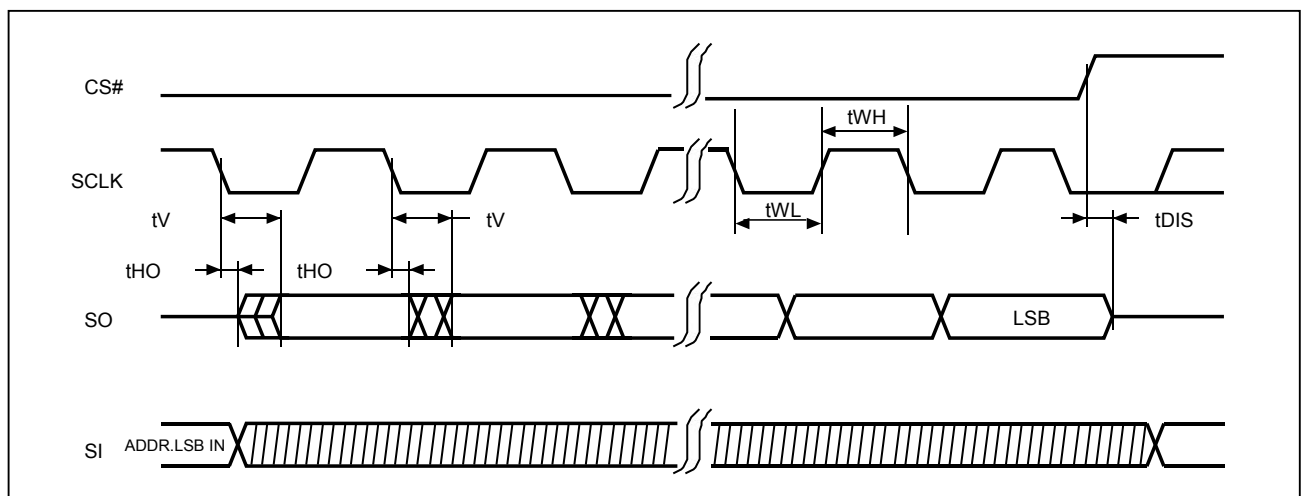
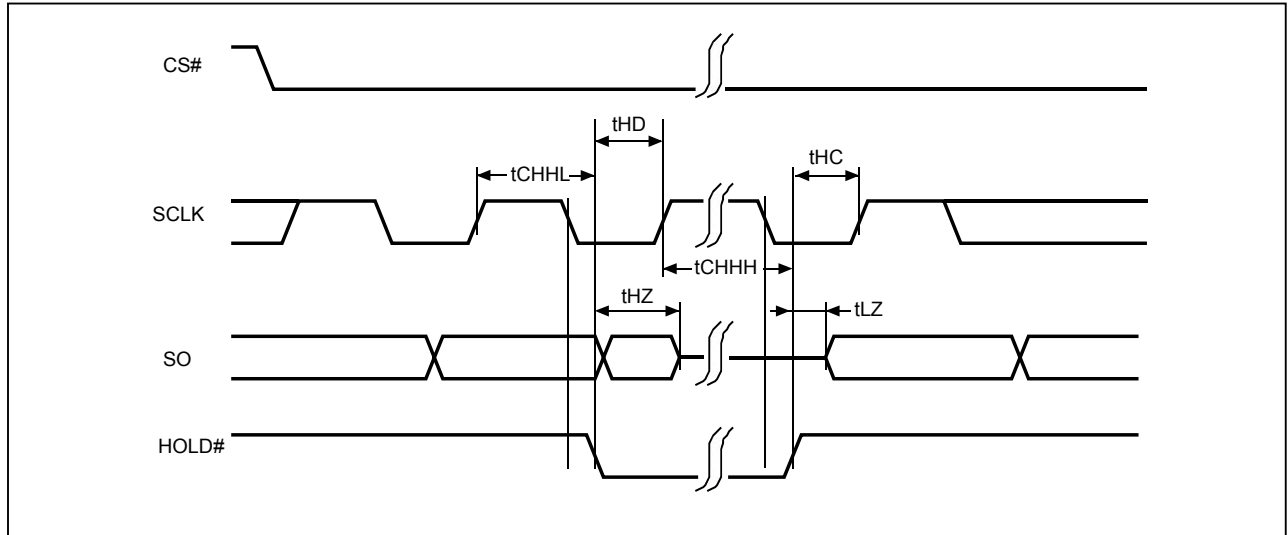

Figure 33. Hold Timing



Note: *SI is "don't care" during HOLD operation.*

14. PACKAGE INFORMATION

14-1. 8-WSON (8x6mm), E.P. 3.4x4.3mm, Recommended for new design

Doc. Title: Package Outline for WSON 8L (8x6x0.8MM, LEAD PITCH 1.27MM, E.P. 3.4x4.3MM)

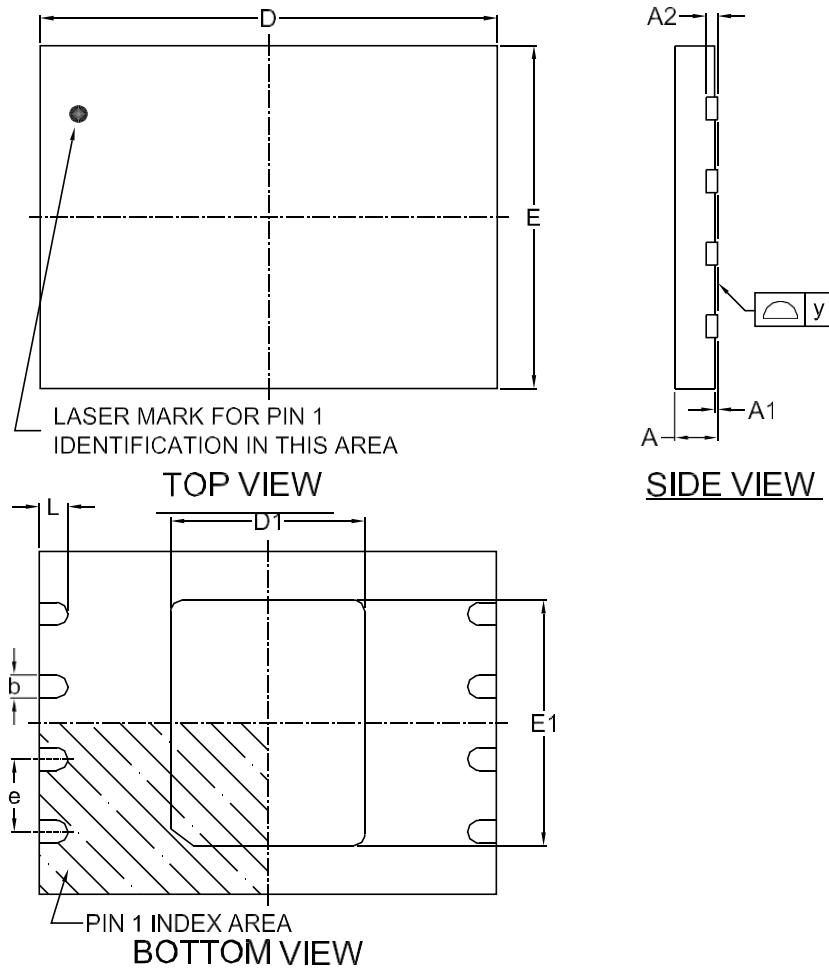

Note:

This package has an exposed metal pad underneath the package. It is recommended to leave the metal pad floating or to connect it to the same ground as the GND pin of the package. Do not connect the metal pad to any other voltage or signal line on the PCB. Avoid placing vias or traces underneath the metal pad. Connection of this metal pad to any other voltage or signal line can result in shorts and/or electrical malfunction of the device.

Dimensions (inch dimensions are derived from the original mm dimensions)

SYMBOL	A	A1	A2	b	D	D1	E	E1	L	e	y
UNIT	0.70	--	--	0.35	7.90	3.30	5.90	4.20	0.40	--	0.00
mm	Min.	--	--	0.20	8.00	3.40	6.00	4.30	0.50	1.27	--
	Nom.	0.80	0.05	--	8.10	3.50	6.10	4.40	0.60	--	0.05
Inch	Max.	0.028	--	--	0.311	0.130	0.232	0.165	0.016	--	0.00
	Min.	--	--	0.008	0.315	0.134	0.236	0.169	0.020	0.05	--
	Nom.	0.032	0.002	--	0.319	0.138	0.240	0.173	0.024	--	0.002
	Max.	--	--	--	--	--	--	--	--	--	--

14-2. 16-SOP (300mil)

Doc. Title: Package Outline for SOP 16L (300MIL)

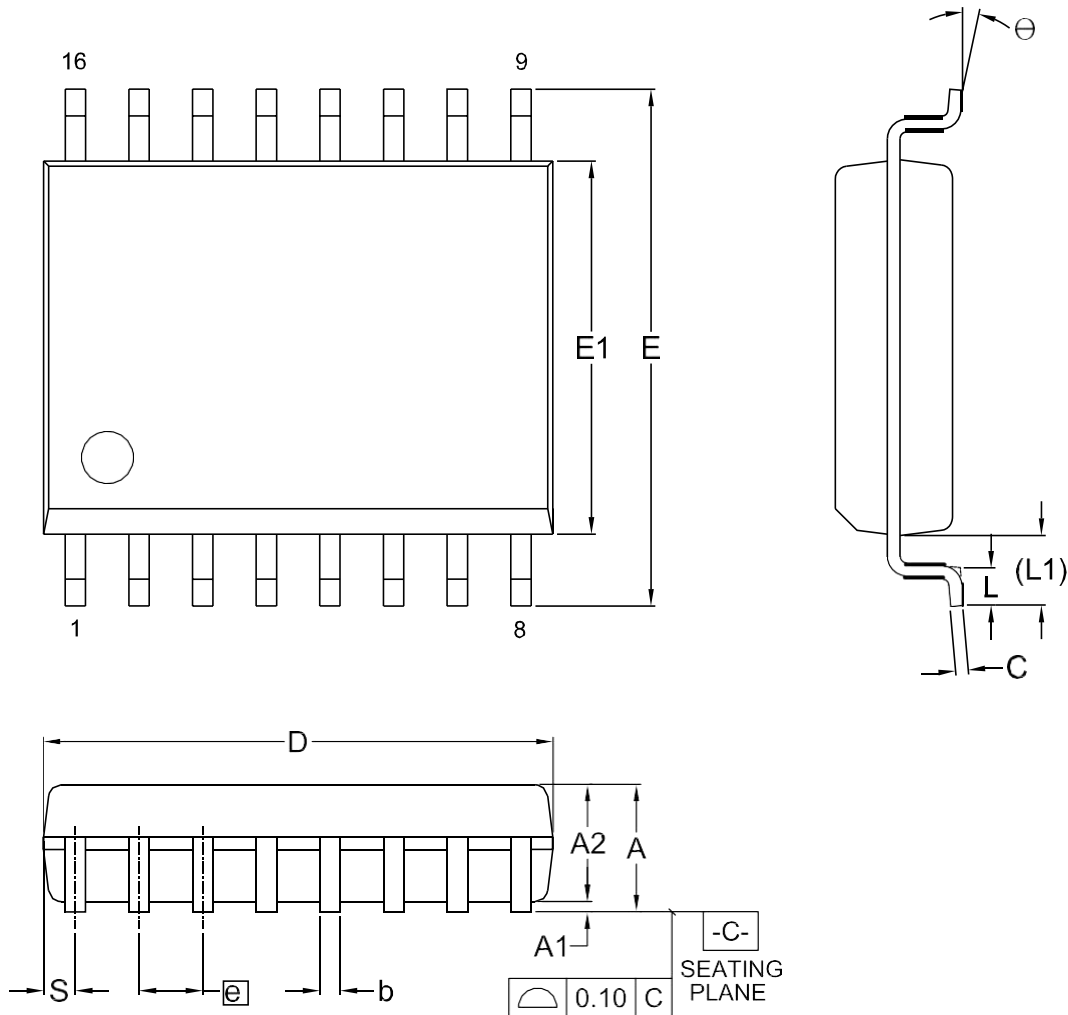

Dimensions (inch dimensions are derived from the original mm dimensions)

SYMBOL		A	A1	A2	b	C	D	E	E1	e	L	L1	S	θ
mm	Min.	---	0.10	2.25	0.31	0.20	10.10	10.10	7.42	---	0.40	1.31	0.51	0°
	Nom.	---	0.20	2.35	0.41	0.25	10.30	10.30	7.52	1.27	0.84	1.44	0.64	5°
	Max.	2.65	0.30	2.45	0.51	0.30	10.50	10.50	7.60	---	1.27	1.57	0.77	8°
Inch	Min.	---	0.004	0.089	0.012	0.008	0.397	0.397	0.292	---	0.016	0.052	0.020	0°
	Nom.	---	0.008	0.093	0.016	0.010	0.405	0.405	0.296	0.050	0.033	0.057	0.025	5°
	Max.	0.104	0.012	0.096	0.020	0.012	0.413	0.413	0.299	---	0.050	0.062	0.030	8°

15. REVISION HISTORY

Rev. No.	Descriptions	Page	Date
0.00	1. Initial Released	All	JUN/26/2014
0.01	1. Removed 16-SOP package for 1Gb	P5, 7	JUL/09/2014
	2. Typo correction for Table 11. The Distribution of ECC Segment and Spare Area	P36	
	3. Modified Figure 2. 63-ball VFBGA.	P8	
0.02	1. Corrected typo on Part Number	P7	NOV/24/2014
	2. Revised the QE bit description - only POR (power-on reset) will trigger the QE bit returning to default mode	P15	
	3. Corrected typo on Unique ID address range from 0x00h/0x01h to 00h/01h	P21	
0.03	1. Revised the 4Gb Reset command will block the Set feature command	P14	JAN/09/2015
	2. Revised the clock rate of 4Gb READ ID as 80MHz max.	P20,40	
	3. Revised the OTP program/ OTP protection flow of 4Gb by adding to set BPx bits value as NOT all "1" first.	P32	
0.04	1. Separated the 4Gb from the original datasheet	ALL	MAR/27/2015
	2. Changed title from "Advanced Information" to "Preliminary".	ALL	
	3. Revised the bad block mark from non-FFh to 00h, and non-FFFFh to 0000h; also revised the page of bad block mark from 1st or 2nd page to 1st and 2nd page	P33/34	
	4. Revised the note for DC Table (ICC1/ICC2, Typ.)	P38	
	5. Supplement footnotes for Table 6-1, 6-2 & Table 7	P30/31	
1.0	1. Removed title from 1Gb as production specification	ALL	MAY/08/2015
	2. Modified wording of "function" as "feature"	P13,20	
	3. Added new command 7Ch function	P11,23,24	
	4. Re-arranged the paragraph of feature register and parameter page	P20-22	
	5. Corrected wording for Table 9. Status Register Bit Descriptions	P34	
1.1	1. Removed "Preliminary" title for 2Gb	ALL	JUL/01/2015
	2. Specified read-out mode description	P5	
	3. Corrected the R2 of spare as under internal ECC protection	P37	
	4. Added overshoot/undershoot waveforms	P39	
	5. Added note mark for NOP	P40	
	6. Recovered the timing spec of Input rising & falling	P39	
1.2	1. Added new package for 8-WSON (8x6mm) with E.P.= 3.4x4.3mm	P7/44	AUG/19/2015
	2. Added Program/Erase endurance cycle and data retention specs	P5	
1.3	1. Corrected the table of "Table 18. PROGRAM/READ/ERASE Characteristics", the typical value was typographical error with minimum value; the maximum value of tRST was typographical error with minimum as well.	P40	AUG/22/2016
	2. Tighten the "y" value of 14-1 8-WSON outline from 0.08mm (max.) to 0.05mm (max.)	P43	
1.4	1. Modified terms of spare area: merged "R2" into "M1".	P37	MAR/06/2017
	2. Tighten parameter timing of tCHSH/tSLCH/tSHCH/tCHSL from 5ns to 4ns.	P40	
	3. Added a product statement for Ordering Information	P7	

Rev. No.	Descriptions	Page	Date
1.5	1. Re-wording the reset command effect on the feature setting	P13	JUN/07/2017
	2. Renaming the register of address B0h from "Secure OTP" to "Configuration"	P13	
	3. Supplement of Secure OTP protect bit of 2G is volatile.	P34	
1.6	Removing Z2I package	P7, 44	JAN/09/2019
1.7	Adding new feature of "Page Read Cache Sequential" for 1Gb	P11,20,38,44	APR/23/2019
1.8	1. Corrected the bit6 definition of ADD=C0h of Table 2-2 as "CRBSY" for 1Gb	P13	DEC/31/2019
	2. Supplement table 9 on the WEL is clear after program/erase completion	P38	
	3. Modified the tWH/tWL waveform of Fig.32	P45	



MX35LF1GE4AB
MX35LF2GE4AB

Except for customized products which have been expressly identified in the applicable agreement, Macronix's products are designed, developed, and/or manufactured for ordinary business, industrial, personal, and/or household applications only, and not for use in any applications which may, directly or indirectly, cause death, personal injury, or severe property damages. In the event Macronix products are used in contradicted to their target usage above, the buyer shall take any and all actions to ensure said Macronix's product qualified for its actual use in accordance with the applicable laws and regulations; and Macronix as well as it's suppliers and/or distributors shall be released from any and all liability arisen therefrom.

Copyright© Macronix International Co., Ltd. 2014 -2019. All rights reserved, including the trademarks and tradename thereof, such as Macronix, MXIC, MXIC Logo, MX Logo, Integrated Solutions Provider, Nbit, Macronix NBit, Hybrid-NVM, HybridFlash, HybridXFlash, XtraROM, KH Logo, BE-SONOS, KSMC, Kingtech, MXSMIO, Macronix vEE, Rich-Book, Rich TV, OctaRAM, OctaBus, OctaFlash, FitCAM, ArmorFlash. The names and brands of third party referred thereto (if any) are for identification purposes only.

For the contact and order information, please visit Macronix's Web site at: <http://www.macronix.com>

MACRONIX INTERNATIONAL CO., LTD.

<http://www.macronix.com>

MACRONIX INTERNATIONAL CO., LTD. reserves the right to change product and specifications without notice.

www.yxd163.com

REV. 1.8, December 31, 2019