

1 特性

- 依照 USB 电池充电技术规格, 修订版本 1.2(BC1.2), 支持 USB DCP D+线路短接至 D-线路
- 依照中国电信行业标准 YD/T 1591-2009, 支持短接模式 (支持 D+线路接至 D-线路)
- 支持在 D+线路上施加 2.7V 电压, 在 D-线路上施加 2.7V 电压的 USB DCP
- 双 USB 充电控制器, FM5888C
- 单 USB 充电控制器, FM5887C
- 工作电压范围: 4.5V 至 5.5V
- FM5888C 采用 SOT23-6 封装
- FM5887C 采用 SOT23-5 封装

2 应用范围

- 车辆 USB 电源充电器
- 带有 USB 端口的 AC-DC 适配器
- 其他 USB 充电器

3 说明

FM5887C 和 FM5888C 是 USB 专用充电端口控制器。自动检测特性监控 USB 数据线路电压, 并且自动在数据线路上提供正确的电气特征, 来为下列专用充电系统配置中为兼容器件充电:

1. 分压器 DCP, 被要求在 D+和 D-线路上分别施加 2.7V 和 2.7V 电压
2. BC1.2 DCP, 被要求将 D+线路短接至 D-线路
3. 中国电信标准 YD/T 1591-2009 短接模式, 被要求将 D+线路短接至 D-线路

4 SIMPLIFIED APPLICATION DIAGRAM

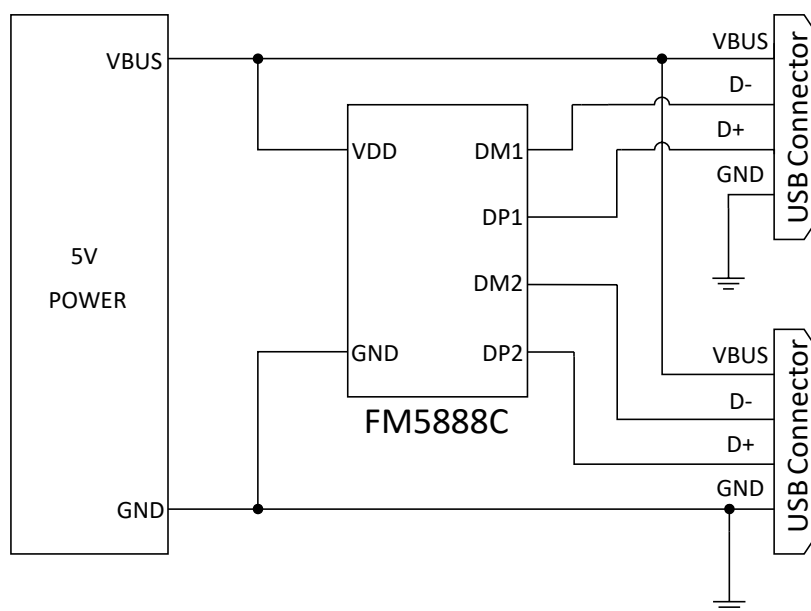

5 PIN FUNCTION

FM5888C (SOT23-6)

(TOP VIEW)

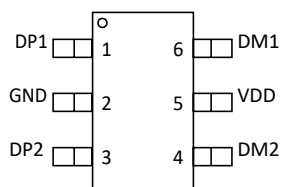

NO.	NAME	TYPE	DESCRIPTION
1	DP1	I/O	Connected to the D+ or D- line of USB connector, provide the correct voltage with attached portable equipment for DCP detection.
2	GND	G	Ground connection
3	DP2	I/O	Connected to the D+ or D- line of USB connector, provide the correct voltage with attached portable equipment for DCP detection.
4	DM2	I/O	Connected to the D+ or D- line of USB connector, provide the correct voltage with attached portable equipment for DCP detection.
5	VDD	P	Power supply. Connect a ceramic capacitor with a value of 0.1uF or greater from the VDD pin to GND as close to the device as possible.
6	DM1	I/O	Connected to the D+ or D- line of USB connector, provide the correct voltage with attached portable equipment for DCP detection.

(1) G=Ground, I=input, O=output, P=Power

FM5887C (SOT23-5)

(TOP VIEW)

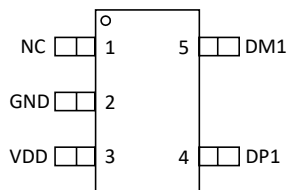

NO.	NAME	TYPE	DESCRIPTION
1	NC	-	No connect pin. Can be grounded or left floating.
2	GND	G	Ground connection
3	VDD	P	Power supply. Connect a ceramic capacitor with a value of 0.1uF or greater from the VDD pin to GND as close to the device as possible.
4	DP1	I/O	Connected to the D+ or D- line of USB connector, provide the correct voltage with attached portable equipment for DCP detection.
5	DM1	I/O	Connected to the D+ or D- line of USB connector, provide the correct voltage with attached portable equipment for DCP detection.

(1) G=Ground, I=input, O=output, P=Power

6 SPECIFICATIONS

6.1 ABSOLUTE MAXIMUM RATING

Over recommended junction temperature range, voltages are referenced to GND (unless otherwise noted)

Parameters		MIN	MAX	UNIT
Voltage range	VDD	-0.3	7	V
	DP1, DM1, DP2, DM2 voltage	-0.3	5.5	
ESD rating	Human Body Model (HBM)		8K	V
Operating Junction Temperature	T _J	-40	125	°C
Storage Temperature Range	T _{STG}	-65	150	°C

(1) Stresses beyond those listed under Absolute Maximum Ratings may cause permanent damage to the device. Exposure to absolute-maximum-rated conditions for extended periods may affect device reliability.

6.2 RECOMMENDED OPERATING CONDITIONS

Voltages are referenced to GND (unless otherwise noted), positive current are into pins.

Parameters		MIN	MAX	UNIT
VDD	Input voltage of VDD	4.5	5.5	V
IVDD	Input current of VDD		260	uA
VDP1	DP1 data line input voltage	0	5.5	V
VDM1	DM1 data line input voltage	0	5.5	V
VDP2	DP2 data line input voltage	0	5.5	V
VDM2	DM2 data line input voltage	0	5.5	V
T _J	Operating Junction Temperature	-40	125	°C

6.3 ELECTRICAL CHARACTERISTICS

Conditions are $-40^{\circ}\text{C} \leq T_J \leq 125^{\circ}\text{C}$, $4.5\text{V} \leq V_{DD} \leq 5.5\text{V}$. Typical values are at 25°C . All voltages are with respect to GND (unless otherwise noted).

Parameters		MIN	TYP	MAX	UNIT
VDD	Input voltage of VDD	4.5	5	5.5	V
IVDD	Input current of VDD		150	260	uA
Output Voltage					
VDP1	DP1 data line output voltage	2.57	2.70	2.84	V
VDM1	DM1 data line output voltage	2.57	2.70	2.84	V
VDP2	DP2 data line output voltage	2.57	2.70	2.84	V
VDM2	DM2 data line output voltage	2.57	2.70	2.84	V
Output impedance					
RDP1	DP1 data line output impedance	10	14	18	KΩ
RDM1	DM1 data line output impedance	10	14	18	KΩ
RDP2	DP2 data line output impedance	10	14	18	KΩ
RDM2	DM2 data line output impedance	10	14	18	KΩ

7 APPLICATION INFORMATION

The FM5887C and FM5888C only provide the correct electrical signatures on the data line of USB charger port and do not provide any power for the VBUS.

The FM5887C and FM5888C provide 12-W USB Charger (Apple 2.4A), the DP1 pin is connected to D+ line and the DM1 pin is connect to the D- line. This is showed in Figure below.

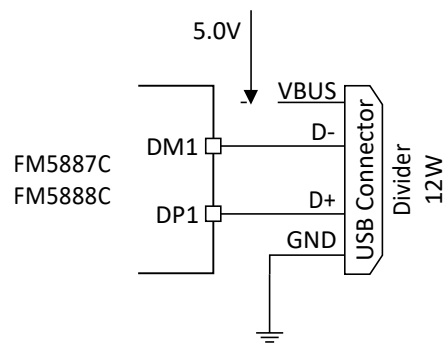

12-W USB Charger Application

8 Outline Information

8.1 FM5888C (SOT23-6)

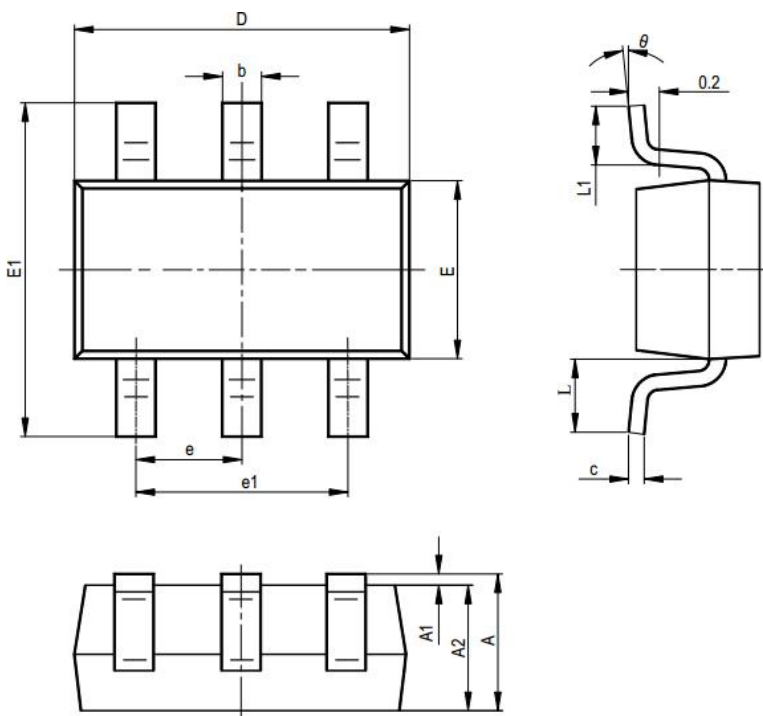

Symbol	Dimensions In Millimeters		Dimensions In Inches	
	Min	Max	Min	Max
A	1.050	1.250	0.041	0.049
A1	0.000	0.100	0.000	0.004
A2	1.050	1.150	0.041	0.045
b	0.300	0.500	0.012	0.020
c	0.100	0.200	0.004	0.008
D	2.820	3.020	0.111	0.119
E	1.500	1.700	0.059	0.067
E1	2.650	2.950	0.104	0.116
e	0.950		0.037	
e1	1.800	2.000	0.071	0.079
L	0.300	0.600	0.012	0.024
θ	0°	8°	0°	8°

8.2 FM5887C (SOT23-5)

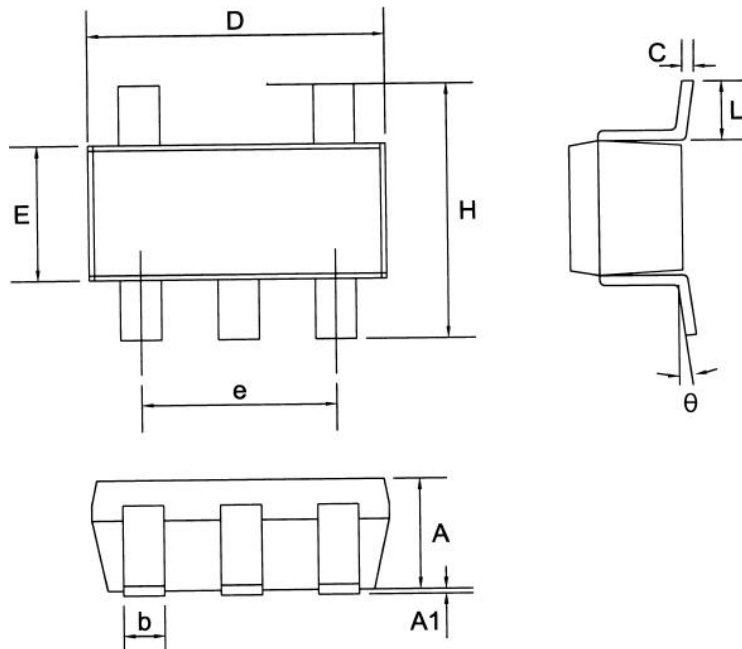

Symbol	Dimensions In Millimeters		Dimensions In Inches	
	Min	Max	Min	Max
A1	0.000	0.100	0.000	0.004
A	1.050	1.150	0.041	0.045
b	0.300	0.500	0.012	0.020
C	0.100	0.200	0.004	0.008
D	2.820	3.020	0.111	0.119
E	1.500	1.700	0.059	0.067
H	2.650	2.950	0.104	0.116
e	1.800	2.000	0.071	0.079
L	0.300	0.600	0.012	0.024
theta	0°	8°	0°	8°