

### General Description

The 3090K uses advanced trench technology to provide excellent  $R_{DS(ON)}$ , low gate charge and operation with gate voltages as low as 4.5V. This device is suitable for use as a wide variety of applications.

### Features

- $V_{DS} = 30V, I_D = 86A$   
 $R_{DS(ON)} < 5 m\Omega @ V_{GS} = 10V$   
 $R_{DS(ON)} < 9.5m\Omega @ V_{GS} = 4.5V$
- High Power and current handing capability
- Lead free product is acquired
- Surface Mount Package

### Application

- PWM applications
- Load switch
- Power management

**100% UIS TESTED!**  
**100%  $\Delta V_{ds}$  TESTED!**

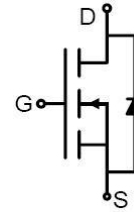

Schematic Diagram

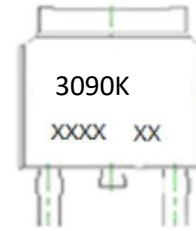

Marking and pin Assignment



TO-252(DPAK) top view

## Package Marking and Ordering Information

Device Marking	Device	Device Package	Reel Size	Tape width	Quantity
3090K	3090K	TO-252	325mm	16mm	2500

**Table 1. Absolute Maximum Ratings ( $T_A=25^\circ C$ )**

Symbol	Parameter	Value	Unit
$V_{DS}$	Drain-Source Voltage ( $V_{GS}=0V$ )	30	V
$V_{GS}$	Gate-Source Voltage ( $V_{DS}=0V$ )	$\pm 20$	V
$I_D$	Drain Current-Continuous( $T_c=25^\circ C$ ) (Note 1)	90	A
	Drain Current-Continuous( $T_c=100^\circ C$ )	60	A
$I_{DM (pluse)}$	Drain Current-Continuous@ Current-Pulsed (Note 2)	344	A
$P_D$	Maximum Power Dissipation( $T_c=25^\circ C$ )	84	W
	Maximum Power Dissipation( $T_c=100^\circ C$ )	42	W
$E_{AS}$	Avalanche energy (Note 3)	270	mJ
$T_J, T_{STG}$	Operating Junction and Storage Temperature Range	-55 To 175	$^\circ C$

**Table 2. Thermal Characteristic**

Symbol	Parameter	Typ	Max	Unit
$R_{\theta JC}$	Thermal Resistance, Junction-to-Case	-	1.8	$^\circ C/W$

# 3090K (文件编号: S&CIC1688)

# N-Channel Trench Power MOSFET

**Table 3. Electrical Characteristics (TA=25°C unless otherwise noted)**

Symbol	Parameter	Conditions	Min	Typ	Max	Unit
<b>On/Off States</b>						
BV <sub>DSS</sub>	Drain-Source Breakdown Voltage	V <sub>GS</sub> =0V, I <sub>D</sub> =250μA	30			V
I <sub>DSS</sub>	Zero Gate Voltage Drain Current	V <sub>DS</sub> =30V, V <sub>GS</sub> =0V			1	μA
I <sub>GSS</sub>	Gate-Body Leakage Current	V <sub>GS</sub> =±20V, V <sub>DS</sub> =0V			±100	nA
V <sub>GS(th)</sub>	Gate Threshold Voltage	V <sub>DS</sub> =V <sub>GS</sub> , I <sub>D</sub> =250μA	1.0	1.5	2.5	V
g <sub>FS</sub>	Forward Transconductance	V <sub>DS</sub> =5V, I <sub>D</sub> =15A		20		S
R <sub>DS(ON)</sub>	Drain-Source On-State Resistance	V <sub>GS</sub> =10V, I <sub>D</sub> =20A		4.0	5	mΩ
		V <sub>GS</sub> =4.5V, I <sub>D</sub> =20A		5.8	9.5	mΩ
<b>Dynamic Characteristics</b>						
C <sub>ISS</sub>	Input Capacitance	V <sub>DS</sub> =15V, V <sub>GS</sub> =0V, f=1.0MHz		1980		pF
C <sub>OSS</sub>	Output Capacitance			320		pF
C <sub>RSS</sub>	Reverse Transfer Capacitance			240		pF
R <sub>g</sub>	Gate resistance	V <sub>GS</sub> =0V, V <sub>DS</sub> =0V, f=1.0MHz		3.2		Ω
<b>Switching Times</b>						
t <sub>d(on)</sub>	Turn-on Delay Time	V <sub>GS</sub> =10V, V <sub>DS</sub> =15V, R <sub>L</sub> =0.75Ω, R <sub>GEN</sub> =3Ω		12		nS
t <sub>r</sub>	Turn-on Rise Time			36		nS
t <sub>d(off)</sub>	Turn-Off Delay Time			49		nS
t <sub>f</sub>	Turn-Off Fall Time			12		nS
Q <sub>g</sub>	Total Gate Charge	V <sub>GS</sub> =10V, V <sub>DS</sub> =25V, I <sub>D</sub> =14A		45		nC
Q <sub>gs</sub>	Gate-Source Charge			3		nC
Q <sub>gd</sub>	Gate-Drain Charge			15		nC
<b>Source-Drain Diode Characteristics</b>						
I <sub>SD</sub>	Source-Drain Current(Body Diode)				90	A
V <sub>SD</sub>	Forward on Voltage	V <sub>GS</sub> =0V, I <sub>S</sub> =20A			1.2	V
t <sub>rr</sub>	Body Diode Reverse Recovery Time	I <sub>F</sub> =20A, dI/dt=100A/μs		15		ns
Q <sub>rr</sub>	Body Diode Reverse Recovery Charge	I <sub>F</sub> =20A, dI/dt=100A/μs		4		nC

Notes 1.The maximum current rating is package limited.

Notes 2.Repetitive Rating: Pulse width limited by maximum junction

temperature Notes 3.EAS condition: T<sub>J</sub>=25°C, V<sub>DD</sub>=30V, V<sub>G</sub>=10V,

R<sub>G</sub>=25Ω

### Test Circuit

#### 1) $E_{AS}$ Test Circuits

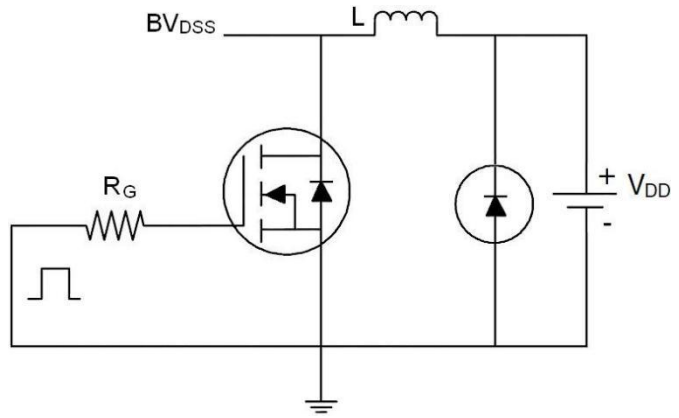
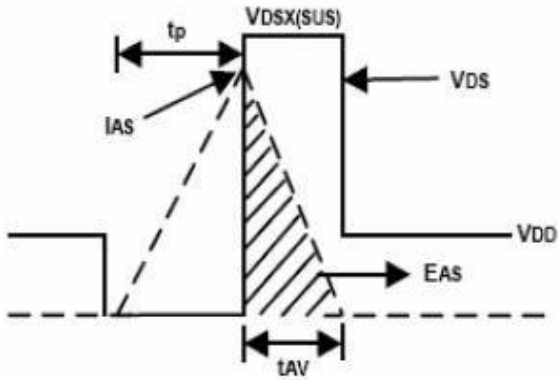

#### 2) Gate Charge Test Circuit:

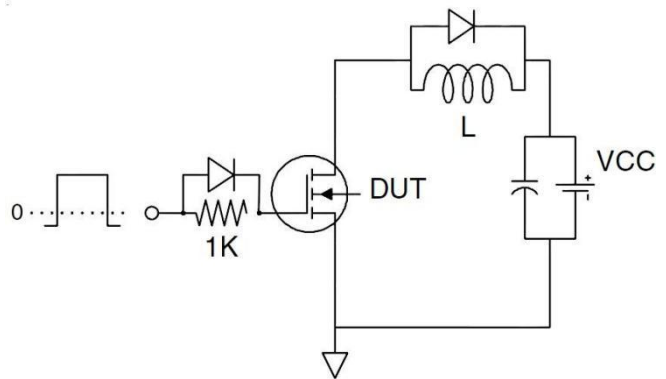
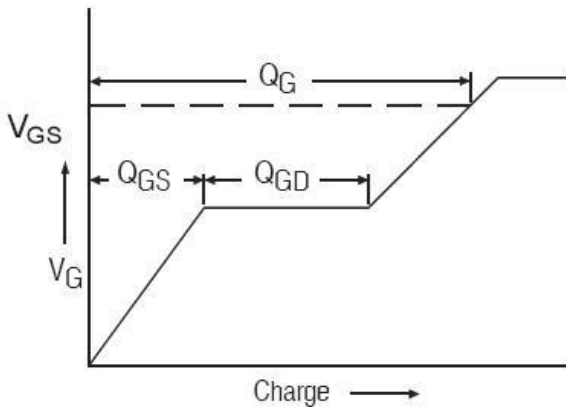

#### 3) Switch Time Test Circuit:

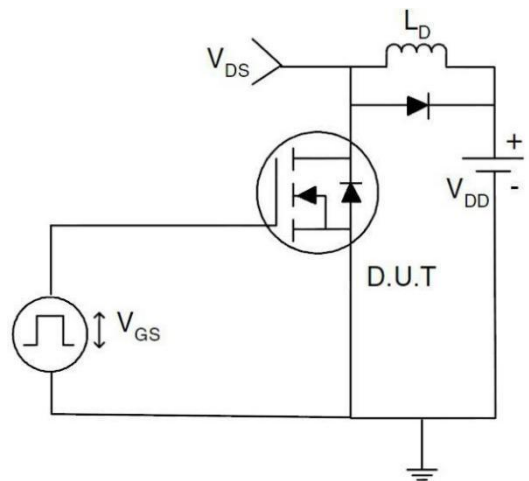
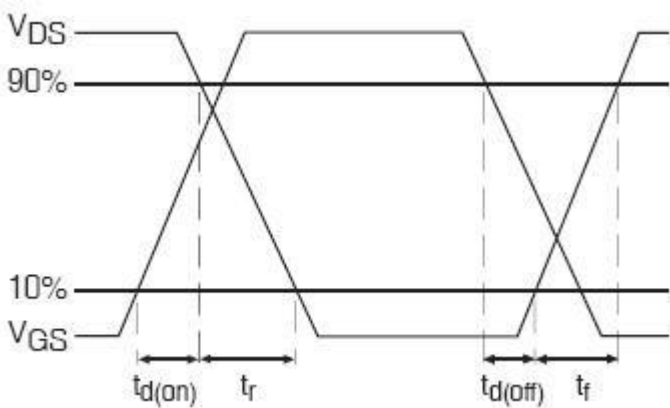

# TYPICAL ELECTRICAL AND THERMAL CHARACTERISTICS (Curves)

Figure 1. Output Characteristics

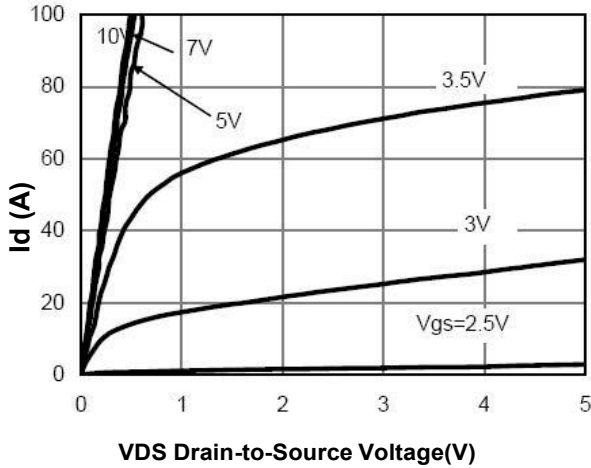

Figure 2. Transfer Characteristics

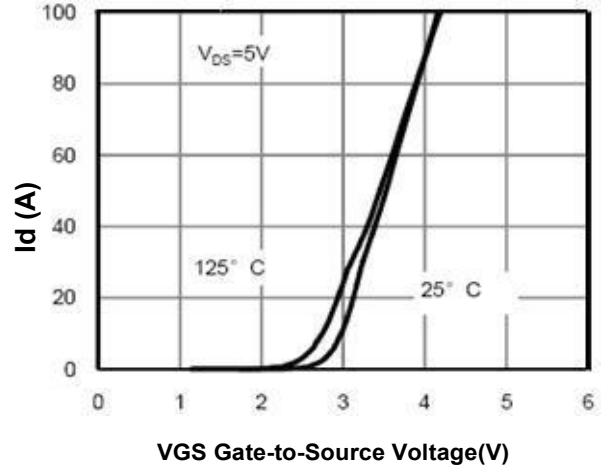

Figure 3. Max  $BV_{DSS}$  vs Junction Temperature

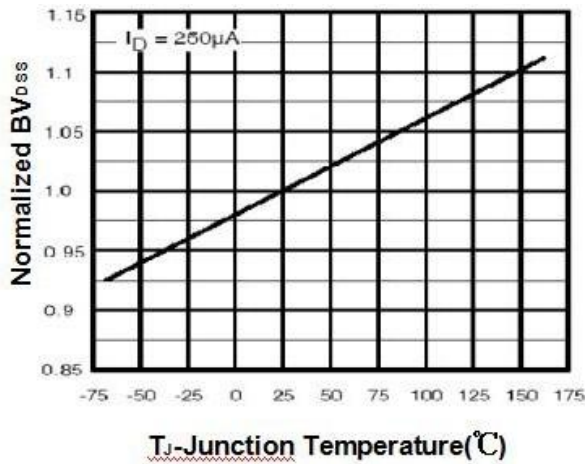

Figure 4. Drain Current

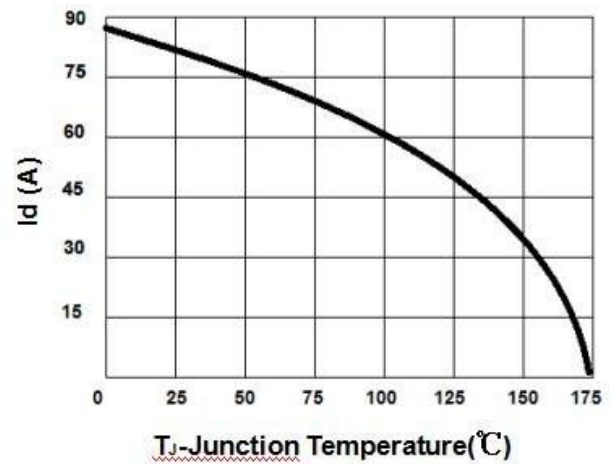

Figure 5.  $V_{GS(th)}$  vs Junction Temperature

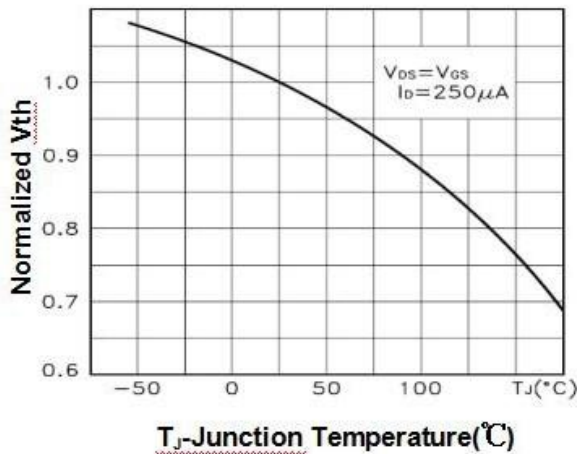
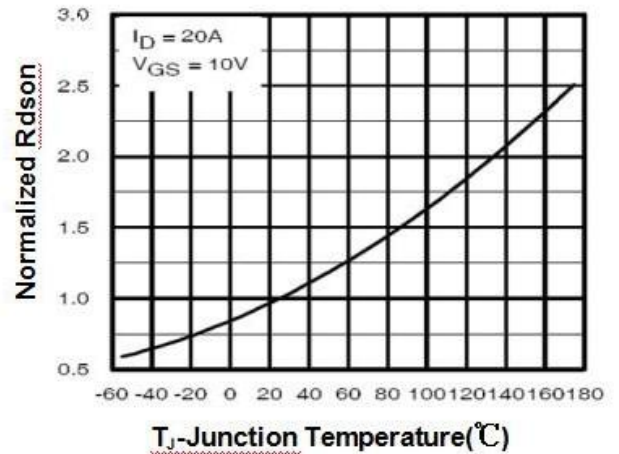
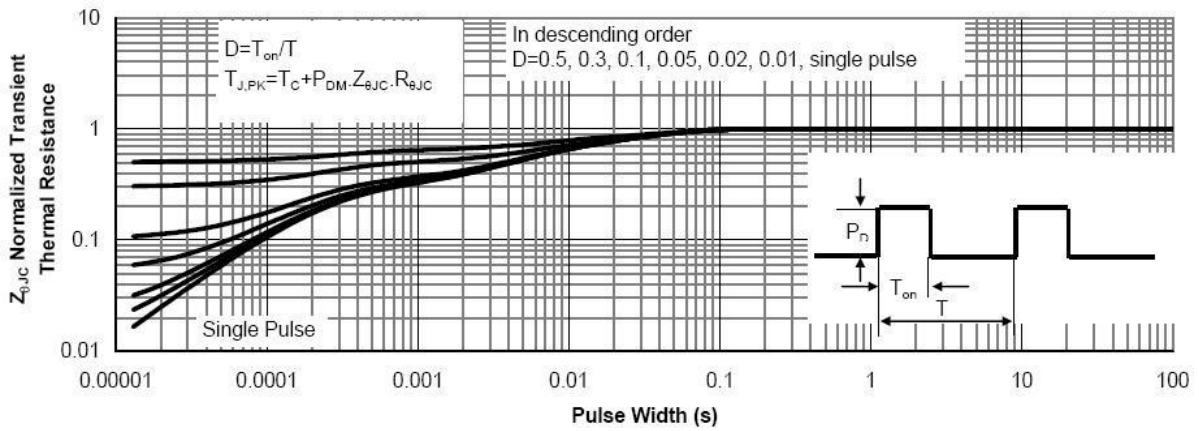
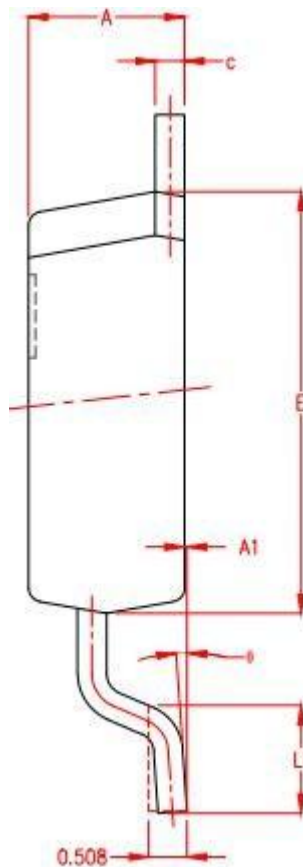
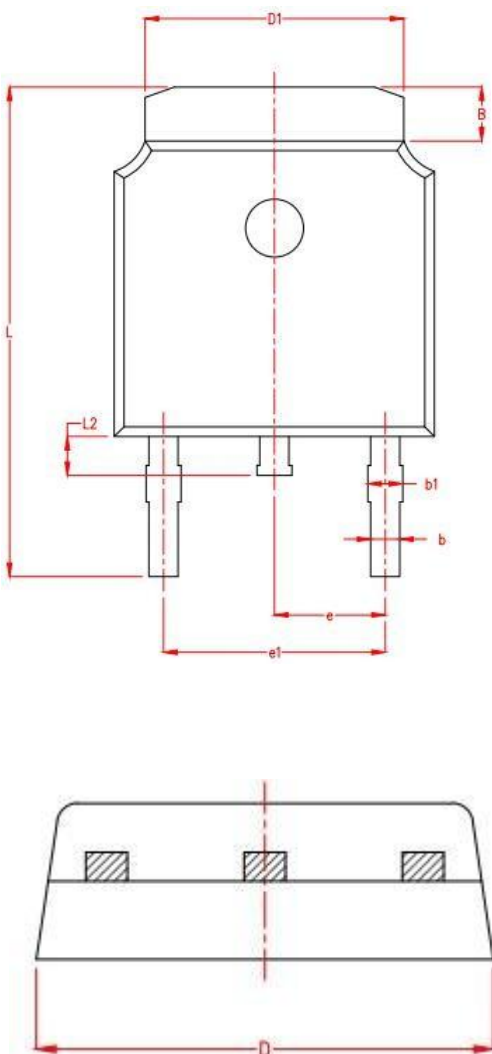

Figure 6.  $R_{DS(on)}$  vs Junction Temperature





### TO-252 Package Information.



SYMBOL	MILLIMETER		
	MIN	NOM	MAX
A	2.15	2.25	2.35
A1	0.00	0.06	0.12
B	0.96	1.11	1.26
b	0.59	0.69	0.79
b1	0.69	0.81	0.93
c	0.34	0.42	0.50
D	6.45	6.60	6.75
D1	5.23	5.33	5.43
E	5.95	6.10	6.25
e	2.286TYP.		
e1	4.47	4.57	4.67
L	9.90	10.10	10.30
L1	1.40	1.55	1.70
L2	0.60	0.80	1.00
$\theta$	0°	4°	8°