



FM3585(文件编号: S&CIC2064)

0.5 to 7.125GHz SPDT Switch for WiFi

Features

- Broadband frequency range: 0.5 to 7.125GHz
- Ultra low switching time: 150ns
- Low insertion 0.80dB@6.0GHz
- Input 0.1dB compression point: 33dBm
- Small, QFN (6-pin, 1.0mm x 1.0mm x 0.45mm) package, MSL1

Applications

- WLAN 802.11ax/ac/b/g/n networks
- WLAN repeaters
- ISM band radios
- Low power transmitting and receiving systems

Description

The FM3585 is a CMOS silicon-on-insulator (SOI), single-pole, double-throw (SPDT) switch. The high linearity and ruggedness performance and extremely low insertion loss makes the device an ideal choice for WLAN applications such as 802.11 a/b/g/n/ac/ax.

The FM3585 SPDT switch is provided in a compact 1.0mm x 1.0mm x 0.45mm 6-lead QFN package. A functional block diagram, pin configuration and package are shown in Figure 1. Signal pin assignments and functional pin descriptions are provided in Table 1.

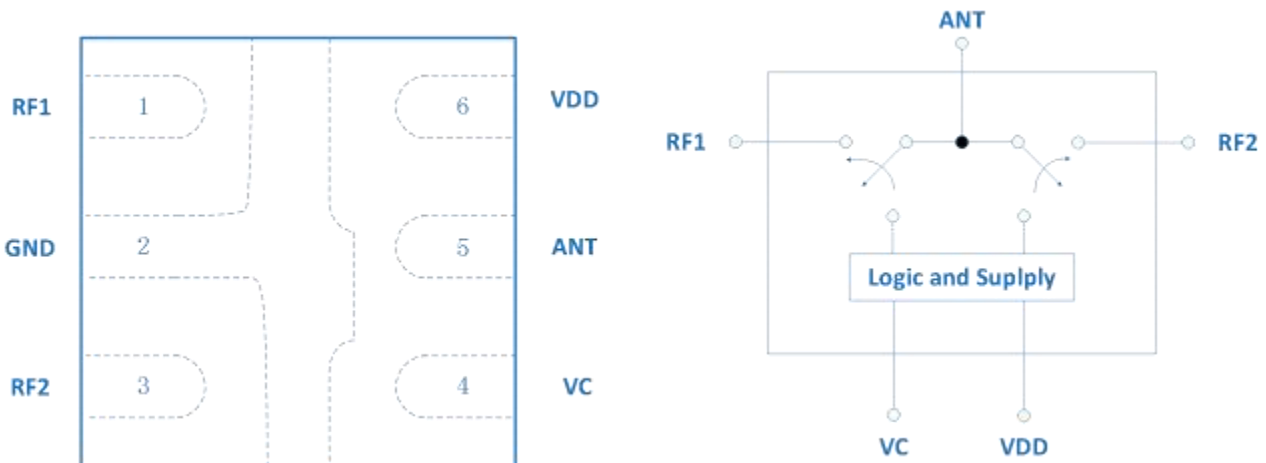

Figure 1 Functional Block and Pin Configuration



FM3585 (文件编号: S&CIC2064)

0.5 to 7.125GHz SPDT Switch for WiFi

Function Characteristics

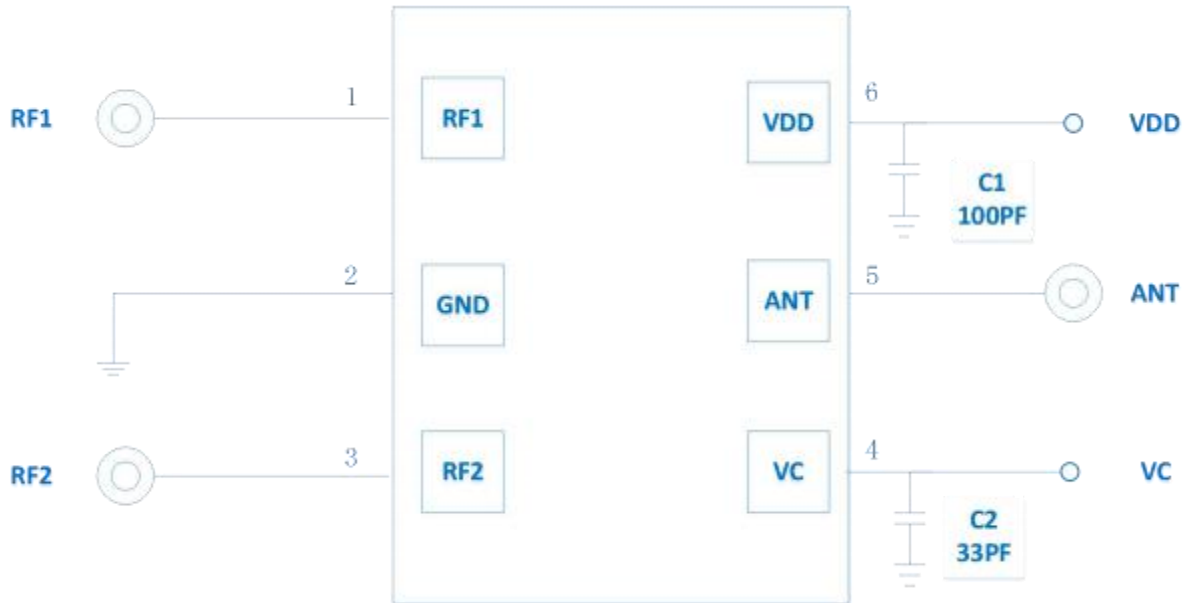

Figure 2 Application Schematic

Table 1 Pin Descriptions

Pin No.	Name	Description	Pin No.	Name	Description
1	RF1	RF Port1	4	VC	Logic Control Voltage
2	GND	Ground	5	ANT	Antenna Port
3	RF2	RF port 2	6	VDD	Power Supply Voltage

Table 2 VC Truth Table for RF Channel Operation Mode

VC	RF Channel Operating Mode
High	ANT to RF1 On
Low	ANT to RF2 On



FM3585(文件编号: S&CIC2064)

0.5 to 7.125GHz SPDT Switch for WiFi

Absolute Maximum Ratings

Table 3 Absolute Maximum Ratings

Parameter	Symbol	Min	Max	Unit	Condition
DC Supply voltage	V _{DD}	-0.3	4.2	V	TA=25°C
Logic Control Voltage	V _{CTL}	-0.3	3.6	V	TA=25°C
Max RF input Power (ANT to RF1/RF2)	P _{INMAX}		33	dBm	F0=2.45GHz, CW, VSWR=1:1, TA=25°C
Device Operating Temperature	T _{OP}	-40	90	°C	
Device Storage Temperature	T _{STG}	-55	150	°C	
Electrostatic Discharge (All Pins)	V _{ESD(HBM)}	1000		V	Human Body Model
	V _{ESD(CDM)}	1000		V	Charged Device Model

Notice3

Exposure to maximum rating conditions for extended periods may reduce device reliability. There is no damage to device with only one parameter set at the limit and all other parameters set at or below their nominal value. Exceeding any of the limits listed here may result in permanent damage to the device.

Table 4 Recommended Operating Conditions

Parameter	Symbol	MIN	TYP	MAX	Unit
Operating Frequency	F ₀	0.5		7.125	GHz
DC Supply Voltage	V _{DD}	1.62	1.8~3.3	3.6	V
Control Voltage High	V _{CH}	1.5	1.8	3.6	
Control Voltage Low	V _{CL}	0	0	0.3	



FM3585 (文件编号: S&CIC2064)

0.5 to 7.125GHz SPDT Switch for WiFi

Electrical Characteristics

Table 5 Nominal Operating Parameters

Parameter	Symbol	Specification			Unit	Condition
		MIN	TYP	MAX		
Nominal Conditions	VDD=3.3V, VCH=1.8V, VCL=0V, PIN=0dBm, ZO=50Ω, TA=25°C Unless Otherwise Stated					
DC Performances						
DC Supply Current	IDD		110	160	μA	
Current on VC	IC			5		
Timing Performances						
RF Path Switching Time	TSW		0.15	0.2	us	50% VC to 10%/90% RF power
Turn On Time	TON			10		50% VDD to 90% RF power
RF Performances						
Insertion Loss (ANT to RF1/RF2)	IL		0.35	0.45	dB	F0=0.5 to 0.96GHz
			0.45	0.5		F0=1.71 to 2.17GHz
			0.50	0.60		F0=2.17 to 2.69GHz
			0.65	0.70		F0=3.6 to 3.8GHz
			0.70	0.75		F0=4.8 to 5.0GHz
			0.75	0.80		F0=5.0 to 6.0GHz
			0.80	0.90		F0=6.0 to 7.2GHz
Isolation (ANT to RF1/RF2)	ISO	50	55		dB	F0=0.5 to 0.96GHz
		40	50			F0=1.71 to 2.17GHz
		35	40			F0=2.17 to 2.69GHz
		30	36			F0=3.6 to 3.8GHz
		28	30			F0=4.8 to 5.0GHz
		25	28			F0=5.0 to 6.0GHz
		20	25			F0=6.0 to 7.2GHz
Input 0.1dB Compression Point(ANT to RF1/RF2)	P0.1dB		34		dBm	F0=0.5 to 6.0GHz, 20% DC
Voltage Standing Wave Ratio(All Pins)	VSWR		1.5:1	2.0:1		F0=0.5 to 6.0GHz
2nd Order Harmonic (ANT to RF1/RF2)	2F0	80	88		dBc	F0=0.8 to 2.7GHz @24dBm
		75	85			F0=4.8 to 6.0GHz @24dBm
3rd Order Harmonic (ANT to RF1/RF2)	3F0	72	75			F0=0.8 to 2.7GHz @24dBm
		70	73			F0=4.8 to 6.0GHz @24dBm
Error Vector Magnitude	EVM	2.5			%	802.11a, 54Mbps, Pin≤27dBm
		2.5				802.11g, 54Mbps, Pin≤27dBm



FM3585(文件编号: S&CIC2064)

0.5 to 7.125GHz SPDT Switch for WiFi

Tape and Reel Dimensions

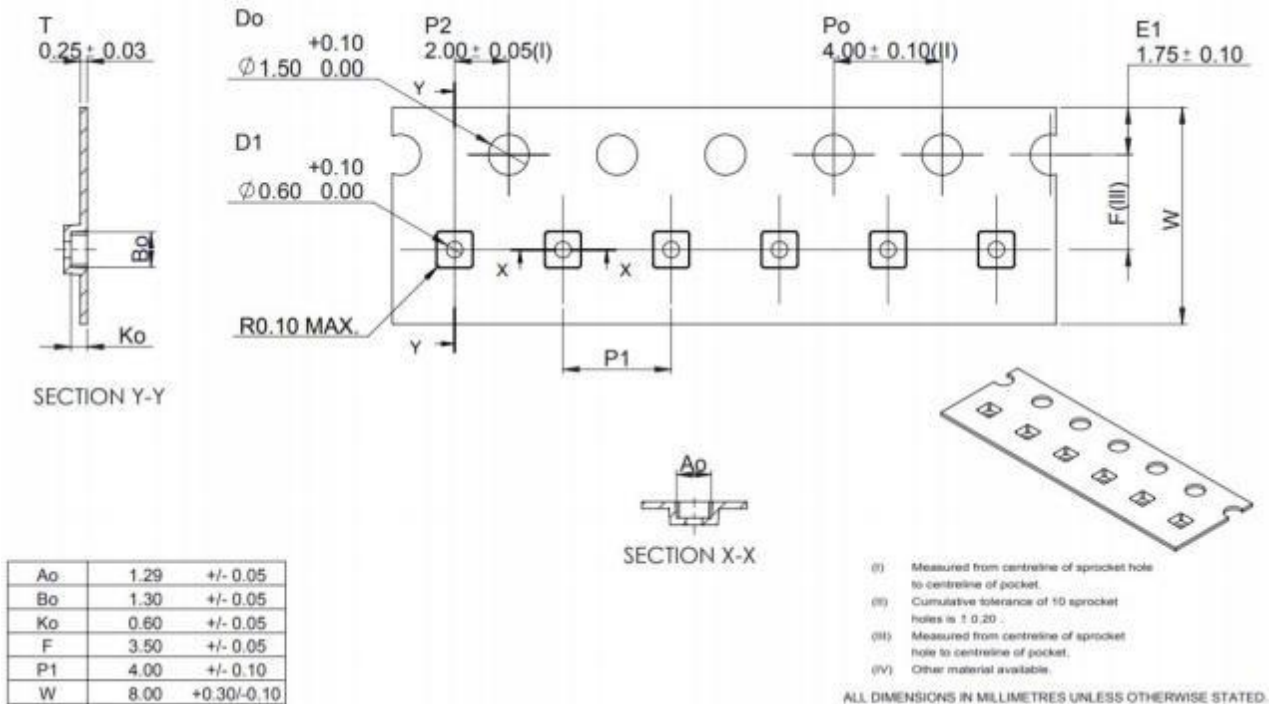

Figure 4 Tape and Reel Dimensions

Reflow Chart

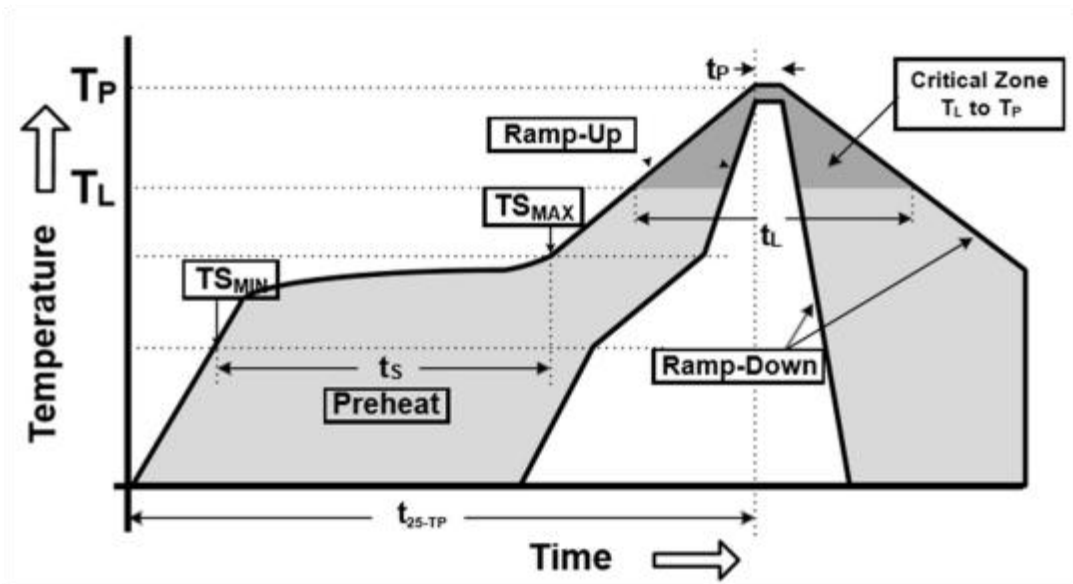

Figure 5 Recommended Lead-Free Reflow Profile



FM3585(文件编号: S&CIC2064)

0.5 to 7.125GHz SPDT Switch for WiFi

Table7 Reflow Chart Parameters

Reflow Profile	Parameter
Preheat Temperature(TSMIN to TS MAX)	150°C to 200°C
Preheat Time(ts)	60 to 180 Seconds
Ramp-Up Rate(TS MAX to TP)	3°C/s MAX
Time Above TL 217°C(tL)	60 to 150 Seconds
Peak Temperature (TP)	260°C
Time within 5°C of Peak Temperature(tp)	20 to 40 Seconds
Ramp-Down Rate(TS MAX to TP)	6°C/s MAX
Time for 25°C to Peak Temperature(t25-TP)	8 Minutes MAX