

FM8545 (文件编号:

Features

- Very Linear Performance
- Off Ports, 'open Type'
- Two pin GPIO control Interface for standard SP4T operation
- Very Small 1.1mm x 1.5mm
- Very low profile, 0.5mm
- Ultra-Low On-resistance, 1.0 Ω

Applications

- Antenna Tuning
- Band Switching
- Impedance Tuning

designed for high performance antenna tuning applications. All RF path performance is enhanced with ultra-low on state resistance and off state capacitance. FM8545 allows the creation of advanced tuning topologies to maximize TRP & TIS performance in space constrained applications.

- The FM8545 SP4T tuner is provided in a compact QFN 1.1mm x 1.5mm x 0.5mm package. A functional block diagram is shown in Figure 1. The pin configuration and package are shown in Figure 2. Signal pin assignments and functional pin description are provided in Table 1.

Description

- The FM8545 is very low loss SP4T specifically

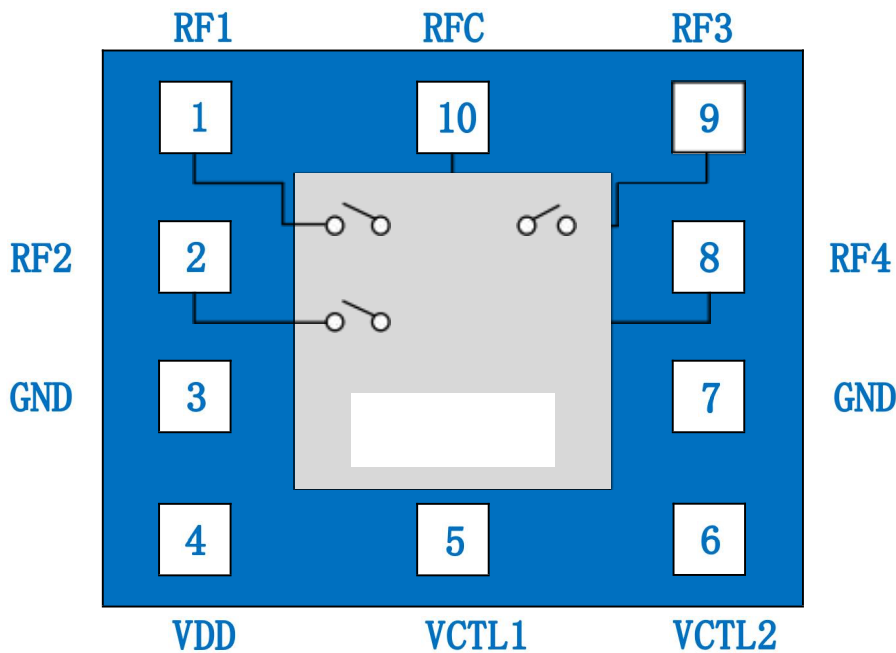

Figure 1. FM8545 Block Diagram

FM8545 (文件编号:

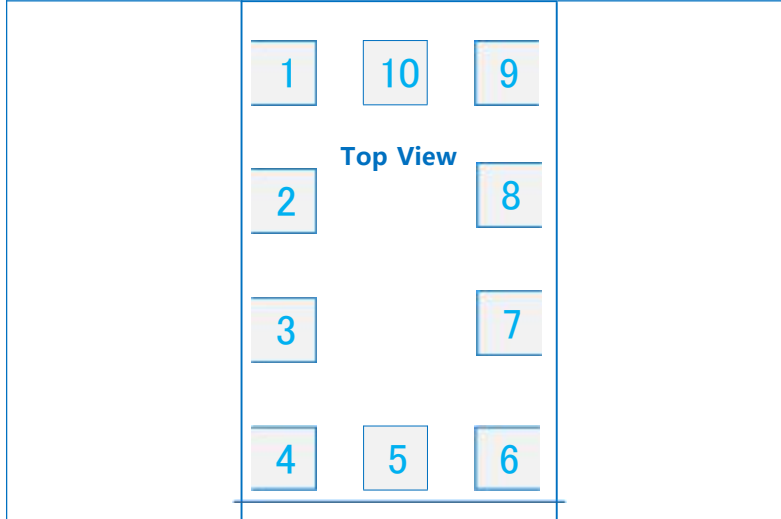

Figure 1. FM8545 Pinout – 10-Pin QFN (Top View)

Table 1. FM8545 Signal Descriptions

Pin#	Name	Details
1	RF1	RF port 1.
2	RF2	RF port 2.
3	GND	Ground
4	VDD	Voltages Supply
5	CTL1	Control Voltage 1.
6	CTL2	Control Voltage 2.
7	GND	Ground
8	RF4	RF port 4
9	RF3	RF port 3
10	RFC	RF Common port.

Table 2. FM8545 Absolute Maximum Ratings

Parameter	Rating	Unit
Supply Voltage, V_{DD}	+4.8	V
Control Voltage, V_{CTL}	+3.3	V
Max voltage between any combination of RF ports or ground V_{RF} , $V_{DD} = 2.85VDC$, $V_{CTL1/2} = 0/1.8VDC$, Temp = 25°C @20% DC	60	VP
Max Input Power between any combination of RF ports or ground V_{RF} , $V_{DD} = 2.85VDC$, $V_{CTL1/2} = 0/1.8VDC$, Temp = 25°C @20% DC	43	dBm
Operating Case Temperature	-40 to +90	°C
Storage Temperature	-55 to +150	°C

FM8545 (文件编号:

Table 3. FM8545 General Electrical Specifications

(Active Mode $V_{DD} = 2.85V$, $CTL=0/1.8V$, $T_{emp} = +25\text{ }^{\circ}C$, Characteristic Impedance $[Z_0] = 50\ \Omega$)

Parameter	Specification			Unit	Conditions
	Min	Typ	Max		
Operating Frequency	700		2700	MHz	
Supply Voltage V_{DD}	2.4	2.85	4.2	V	
Supply Current I_{DD}		85	130	μA	
Control Voltage High V_{CLT1} , V_{CLT2}	1.3	1.8	2.7	V	
Control Voltage Low V_{CLT1} , V_{CLT2}	0	0	0.45	V	
Control Current I_{CTL}		0.01		μA	$V_{CTL} = 1.8V$

Table 4. FM8545 Control Logic

Logic State	Mode	CLT1	CLT2	State Description	RF Applied
1	Active	V_{LOW}	V_{LOW}	RFC to RF1 ON	Yes
2	Active	V_{LOW}	V_{HIGH_CTL}	RFC to RF2 ON	Yes
3	Active	V_{HIGH_CTL}	V_{LOW}	RFC to RF3 ON	Yes
4	Active	V_{HIGH_CTL}	V_{HIGH_CTL}	RFC to RF4 ON	Yes

Table 5. FM8545 Electrical Specification

(Active Mode $V_{DD} = 2.85V$, $CTL=0/1.8V$, $T_{emp} = +25\text{ }^{\circ}C$, Characteristic Impedance $[Z_0] = 50\ \Omega$)

Parameter	Specification			Unit	Conditions
	Min	Typ	Max		
Insertion Loss (RFC to RFX) $X=1,2,3,4$		0.35	0.45	dB	700 – 915 MHz
		0.45	0.65	dB	915 – 1910 MHz
		0.65	0.95	dB	1910 – 2700 MHz
Isolation (RFC to RFX) $X=1,2,3,4$	20	25		dB	700 – 915 MHz
	15	21		dB	915 – 1910 MHz
	12	16		dB	1910 – 2700 MHz
Isolation (RFX to RFX) $X=1,2,3,4$	22	26		dB	700 – 915 MHz
	18	21		dB	915 – 1910 MHz
	12	19		dB	1910 – 2700 MHz
Return Loss Logic States 1,2,3 & 4	18	23		dB	915 MHz
	13	15		dB	1910 MHz

FM8545 (文件编号:

Table 6. FM8545 Electrical Specification

(Active Mode $V_{DD} = 2.85V$, $CTL=0/1.8V$, $T_{emp} = +25\text{ }^{\circ}C$, Characteristic Impedance $[Z_0] = 50\ \Omega$)

Parameter	Specification			Unit	Conditions
	Min	Typ	Max		
RON (RFC to RF1/RF2/RF3/RF4)		1.0	1.5	Ω	Switch On path
Coff (RFC to RF1/RF2/RF3/RF4)		150	170	fF	Switch Off path
Input 0.1dB compression point		+43		dBm	700 to 2690MHz, CW, RFC to RF1/RF2/RF3/RF4
Second Harmonics		-73	-68	dBm	700 to 2690MHz, Pin = 26 dBm
Third Harmonics		-75	-68	dBm	
Second Harmonics		-63	-55	dBm	824 to 915MHz, Pin = 35 dBm
Third Harmonics		-68	-58	dBm	
Second Harmonics		-63	-55	dBm	1710 to 1910MHz, Pin = 33 dBm
Third Harmonics		-70	-60	dBm	
Start Up Time		10	20	μS	10% VDD ramp up to 90% of final RF amplitude
On switching speed		4	5	μS	50% VCTL to 90% RF
OFF Switching Speed		4	5	μS	50% VCTL to 10% RF

FM8545 (文件编号:

Handling Information

FM8545 application schematic is shown in Figure 3. Component value is shown in Table 9. (Note1)

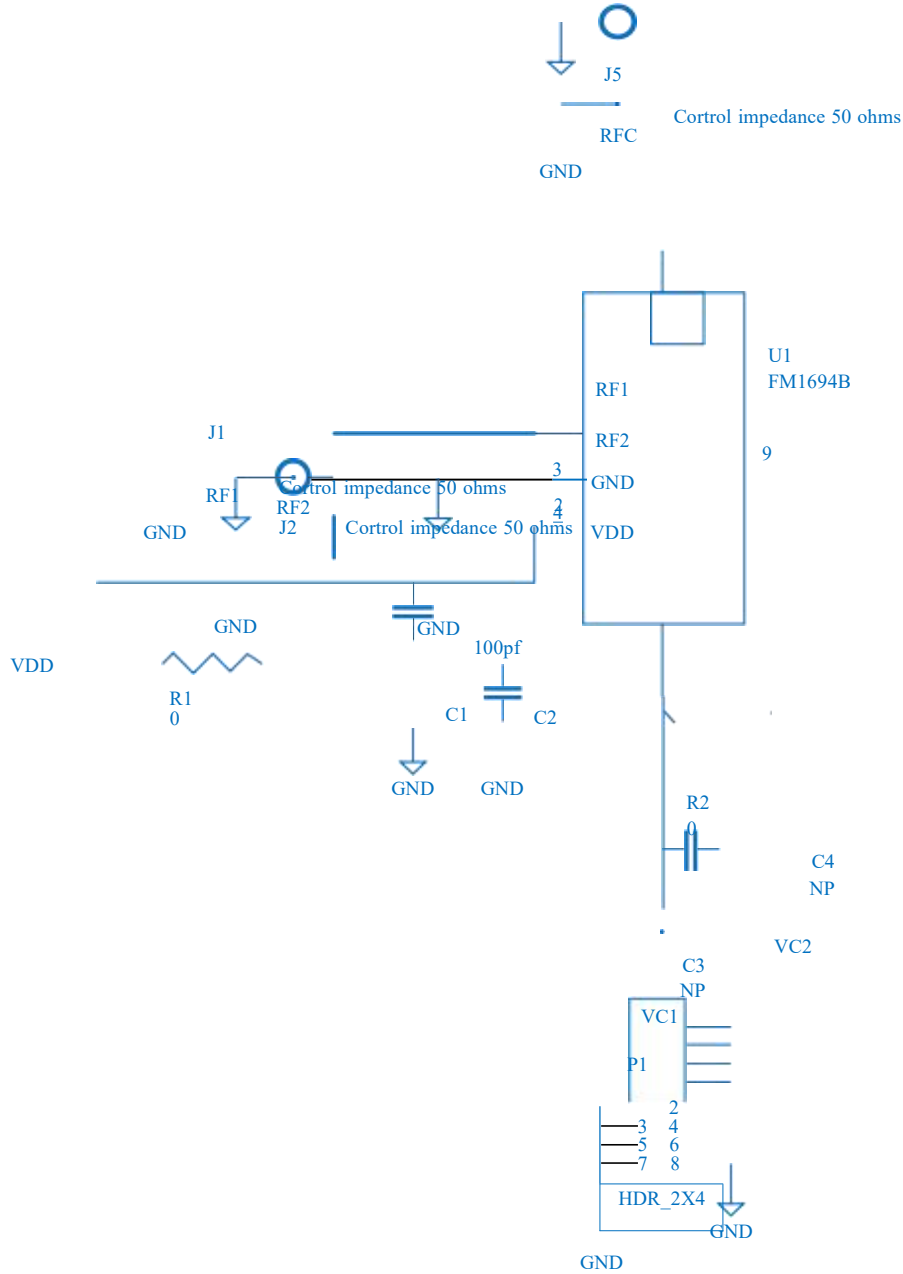

Figure 3. FM8545 Application Schematic

