

## DESCRIPTION

The TC2466A provides an integrated motor driver for cameras, consumer products, toys and other application with low-voltage or battery-powered motion control. The TC2466E can supply up to 1.8A of output DC current. It operates on a motor power supply (VM) from 2 to 11V and a device power supply voltage (VCC) of 2V to 6V. Ultra- low  $R_{DS-ON}$  allows SOP-8 package available. The TC2466A has a PWM (INA、INB) input interface. Full protections are integrated with over-current protection, under-voltage lockout and over-temperature shutdown.

## FEATURE

H-Bridge Motor Driver

- DC Motor or Other Loads
- Low On-Resistance : 280m $\Omega$

1.8-A Maximum DC Drive Current

Separate Motor and Logic Supply

- Motor VM : 2 to 11V
- Logic VCC : 2V to 6V

Low-Stand-by Current  $\leq 2\mu A$  VM=VCC=5V

Small Package and Footprint

- 8-Pin ESOP with Thermal PAD

- 8-Pin SOP

Protection Features

- VCC Under-voltage Lockout
- Over-Current Protection
- Thermal Shutdown

## APPLICATION

Electric toothbrush, Electric lock

Cameras

DSLR Lenses

Consumer Products

Toys

Robotics

## PIN DESCRIPTION

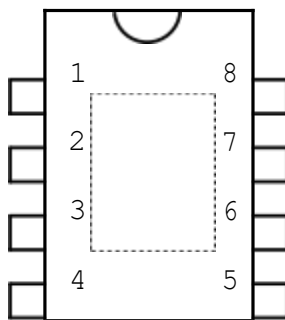

(ESOP-8)  
TC2466E

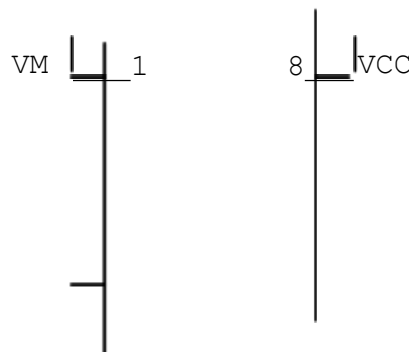

(SOP-8)  
TH2466A

Pin number	Pin name	I/O	Description
1	VM	--	Motor power supply
2	OUTA	O	Motor drive output A
3	OUTB	O	Motor drive output B
4	GND	--	Ground
5	INB	I	Logic input B
6	INA	I	Logic input A
7	SLP	--	Sleep Mode Control input
8	VCC	--	Logic power supply

**BLOCK DIAGRAM**

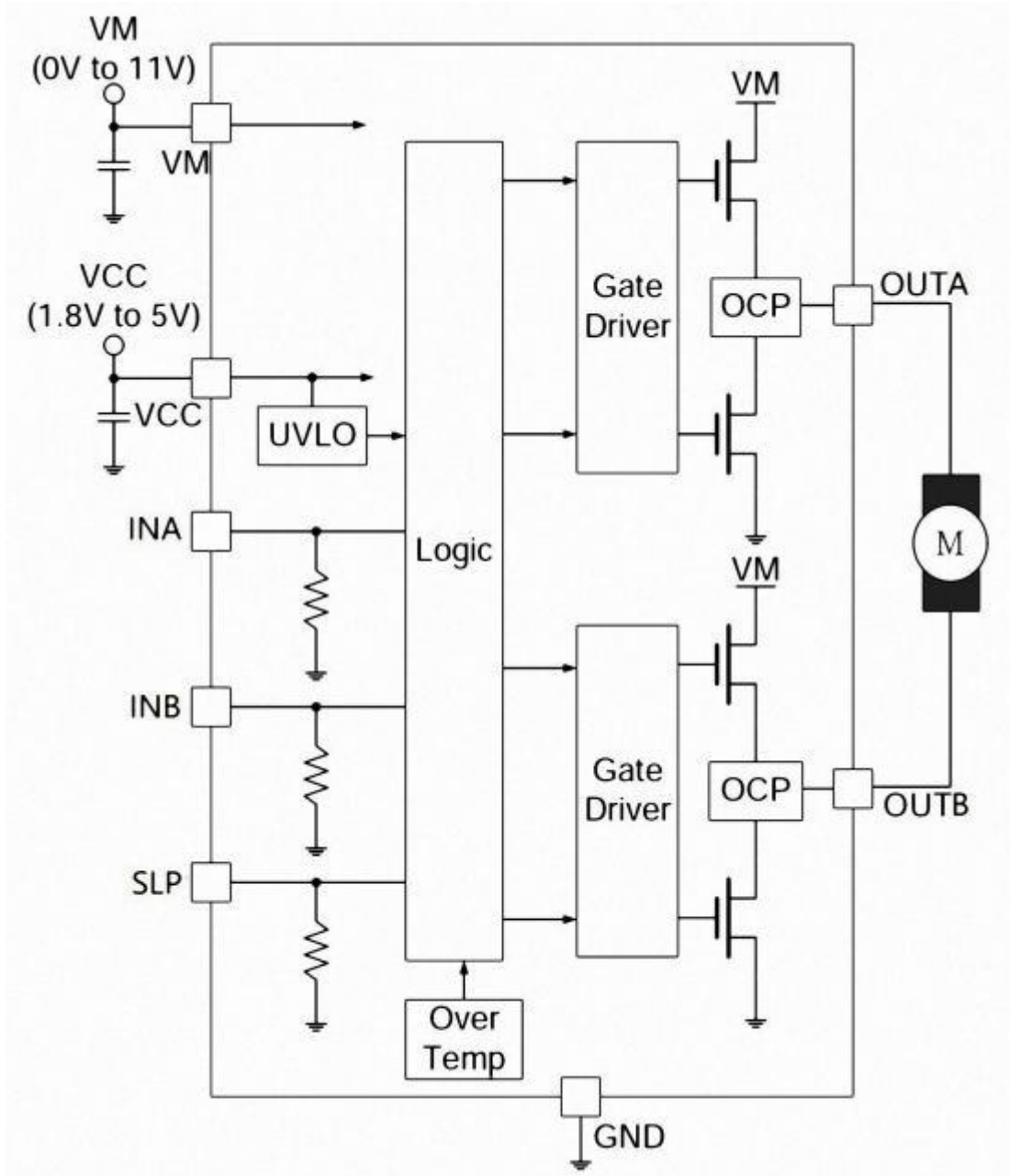

**ABSOLUTE MAXIMUM RATINGS**

Parameters	Symbol		Value	Unit
Logic power supply voltage , VCC	VCC		7	V
Motor power supply voltage , VM	VM		11	V
Power dissipation	Pd	ESOP-8	0.99	W
Operating Temperature, Top	Topr		-20~85	°C
Junction temperature	Tj		150	°C

Storage Temperature, Tstg	T <sub>STG</sub>	-55~150	°C
Manual welding temperature		350~370	°C
Peak output current	I <sub>OP</sub>	3.5	A
Continuous Output Current	I <sub>OC</sub>	1.8	A
PWM Frequency	F <sub>PWM</sub>	40	KHz

Note:The maximum continuous output current depends on the heat dissipation conditions,1.8A(ESOP8) ;1.4A(SOP8).

## RECOMMENDED OPERATING CONDITIONS (Ta=25°C)

Parameter	Symbol	Rating	Unit
Power supply voltage	V <sub>CC</sub>	2.0~6	V
Motor Power supply voltage	V <sub>M</sub>	9.6	V
High Input Voltage	V <sub>IN</sub>	0~6	V
Low Input Voltage	V <sub>IN</sub>	-0.8~0	V
Continuous Output Current	I <sub>OUT</sub>	-1400~1400	mA

Note:The maximum continuous output current depends on the heat dissipation conditions,1.8A(ESOP8) ;1.4A(SOP8).

## ELECTRICAL CHARACTERISTICS

(Ta=25°C, VCC=3V, VM=6V, unless otherwise specified )

Parameter	Symbol	Test Condition	Min	Typ	Max	Unit
<b>Overall Circuit</b>						
Standby Current	I <sub>CCST</sub>	INA=INB=GND SLP=GND	—	1	2	μA
<b>Input control</b>						
High Input Voltage	V <sub>INH</sub> V <sub>SLP</sub>		2	4	6	V
Low Input Voltage	V <sub>INL</sub> V <sub>SLP</sub>		—	—	0.8	V
High Input Current	I <sub>INH</sub> I <sub>SLP</sub>	V <sub>IN</sub> =3V	—	250	400	μA
Low Input Current	I <sub>INL</sub> I <sub>SLP</sub>	V <sub>IN</sub> =0V	-1	0	—	μA
Pull Down Resistor	R <sub>IN</sub> R <sub>SLP</sub>		—	500	—	KΩ
<b>Driving</b>						
Output Impedance(HS+LS)	R <sub>ON</sub>	I <sub>o</sub> =±200mA		0.5	0.6	Ω
<b>Protection</b>						

ESD	$T_{ESD}$	HMB	$\pm 3$	$\pm 6$	$> 8$	KV
Thermal shutdown temperature	$T_{TSD}$	Die temperature	—	150	—	$^{\circ}C$

## INPUT AND OUTPUT TRUTH TABLE

INPUT			OUTPUT	
SLP	INA	INB	OUTA	OUTB
0	1	0	Z	Z
1	0	0	Z	Z
1	0	1	L	H
1	1	0	H	L
1	1	1	L	L

## OUTPUT AND INPUT WAVEFORM

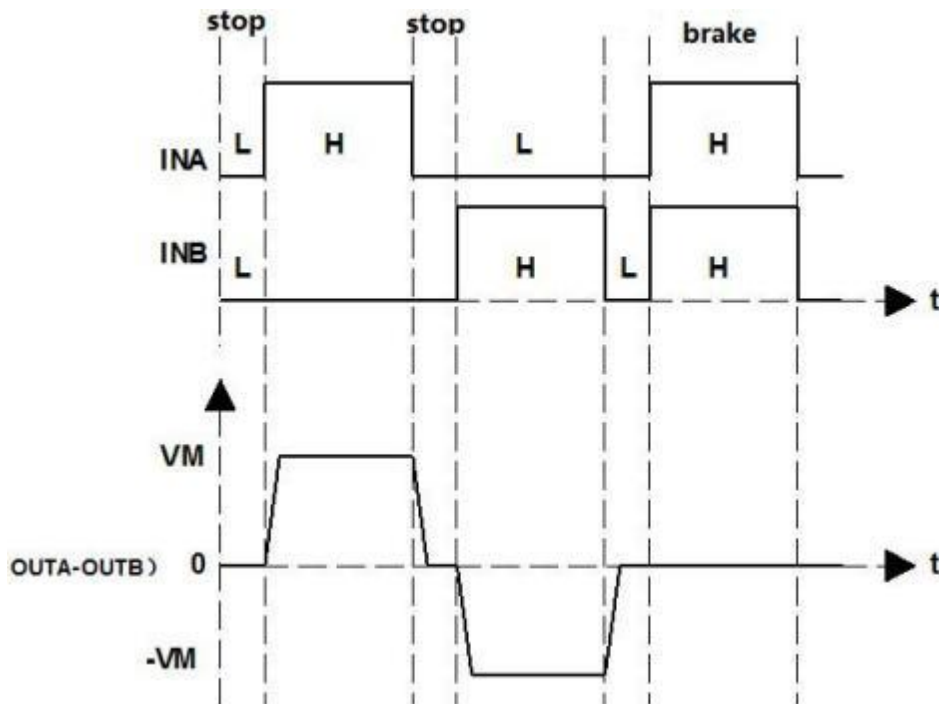

## POWER SUPPLY RECOMMENDATION

Having appropriate local bulk capacitance is an important factor in motor-drive system design. It is generally beneficial to have more bulk capacitance.

The amount of local bulk capacitor needed depends on the following factors ,

The highest current required by the motor system.

The power-supply capacitance and ability to source current

- The amount of parasitic inductance between the power supply and motor system
- The acceptable voltage ripple
- The type of motor used (brushed DC motor, brushless DC motor, stepper motor)
- The motor braking method

The inductance between the power supply and motor drive system limits the rate at which current can change from the power supply. If the local bulk capacitance is too small, the system responds to excessive current demands or dumps from the motor with a change in voltage. When adequate bulk capacitance is used, the motor voltage remains stable and high current can be quickly supplied.

The voltage rating for bulk capacitors should be higher than the operating voltage, to provide margin for cases when the motor transfers energy to supply.

## PCB LAYOUT GUIDANCE

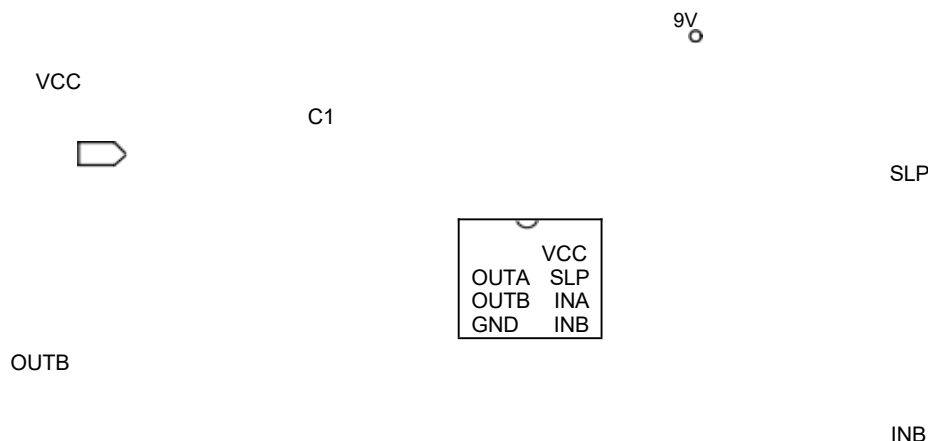

SLP=VCC,enable output; SLP=GND, disable output(sleep mode)

### Test Circuit

The capacitor C1 connected between the GND and the VM pins must be located as close as possible to the TC2466A chip. In different applications, C1(show as above) is recommended to use a 0.1uF in 3V applications; a 1uF is recommended for 4.5V applications; a 4.7uF is recommended for 6V applications; in 9.6V applications, it is recommended to use 22uF, all these capacitors should be SMD package.The connection between the negative pole of the capacitor and the GND terminal of the IC should be as short as possible. That is to say, the line route should not far away.

When the application board has capacitors while filtering for other chips that is far away from the TC2466A, it need to place a small capacitor for TC2466A.

The capacitor C3 preferably soldering to the motor poles instead of placing it on the PCB. When it is inconvenient to soldering on the motor poles, it can be mount on the PCB. The following diagram is the PCB layout reference .

### H-Bridge Motor Driver

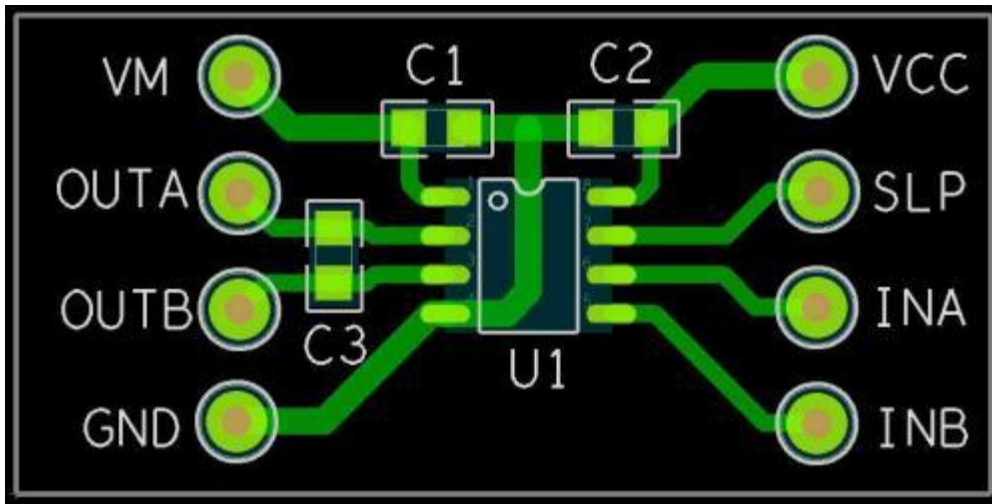

### PACKAGE DIMENSION

ESOP-8 (E2=2mm;D1=3mm)

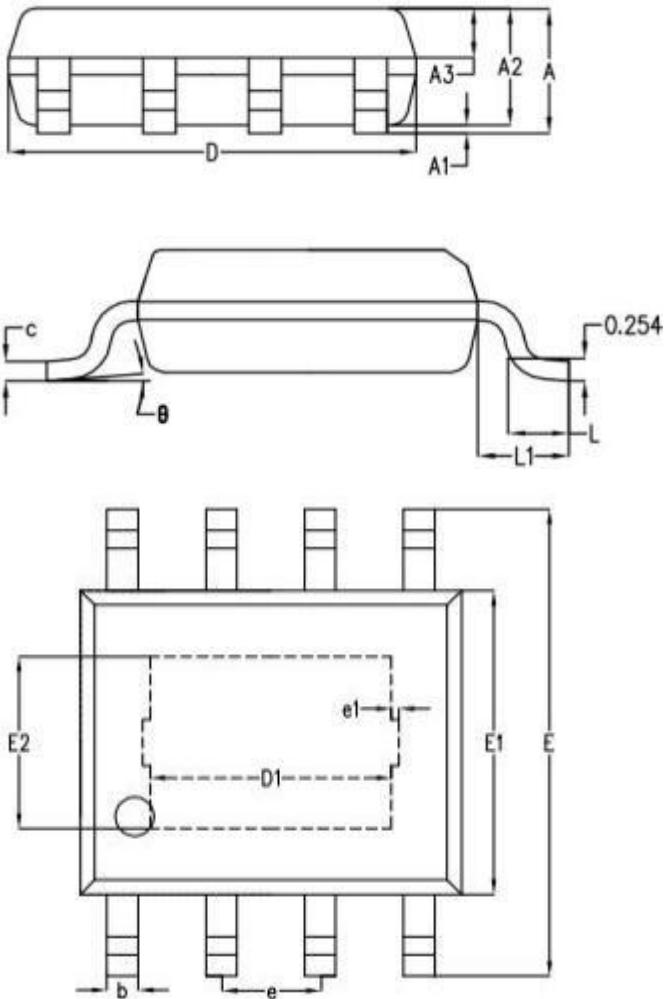

H-Bridge Motor Driver

SOP-8

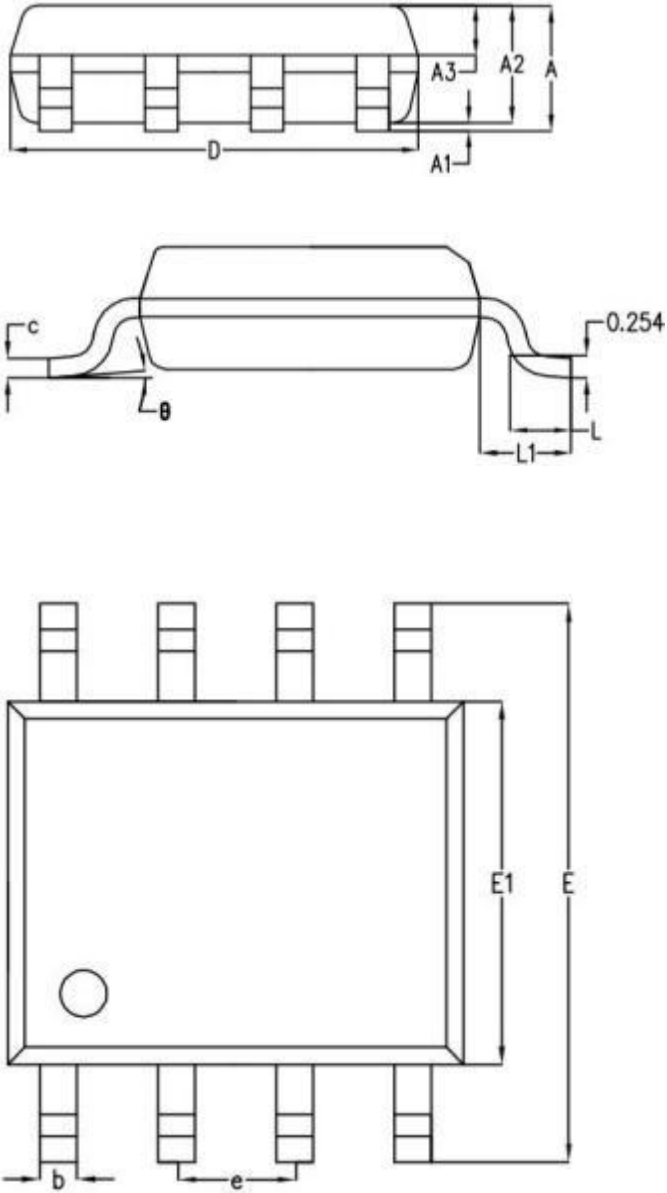

SYMBOL	MILLIMETER		
	MIN	NOM	MAX
A	-	1.50	1.55
A1	-	0.10	0.15
A2	1.35	1.40	1.45
A3	0.55	0.60	0.65
b	0.35	0.40	0.45
c	0.17	0.22	0.25
D	4.85	4.90	4.95
E	5.90	6.00	6.10
E1	3.80	3.90	4.00
e	1.27BSC		
L	0.60	0.65	0.70
L1	1.05BSC		
θ	0°	4°	6°