

18V2A Synchronous Buck Converter

1 Features

- Synchronous Buck Converter
 - Internal Power MOSFET
 - Wide 4.5V to 18V Input Voltage Range
 - Output Current : 2A
 - 600KHZ frequency Operation
 - 0.6V Reference
 - Soft Start
 - Output Short With Hiccup Mode
- Multiple Protection
 - Input Over Voltage protection
 - Input Under Voltage protection
 - Output Over Voltage protection
 - Over Current protection With Hiccup
 - Over Temperature Protection

2 Applications

- Distributed Power Systems
- Digital Set Top Boxes
- Flat Panel Television and Monitors
- Notebook Computer
- Wireless and DSL Modems

Efficiency @ $V_{out}=5V$

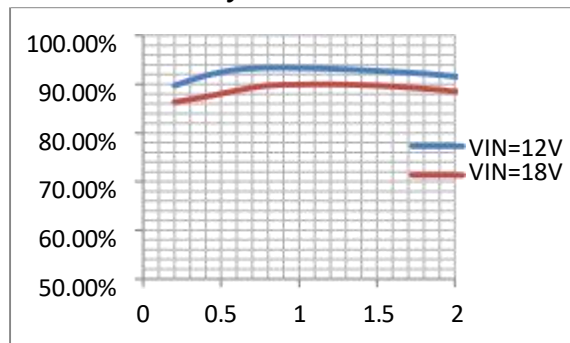

3 Typical Application Circuit

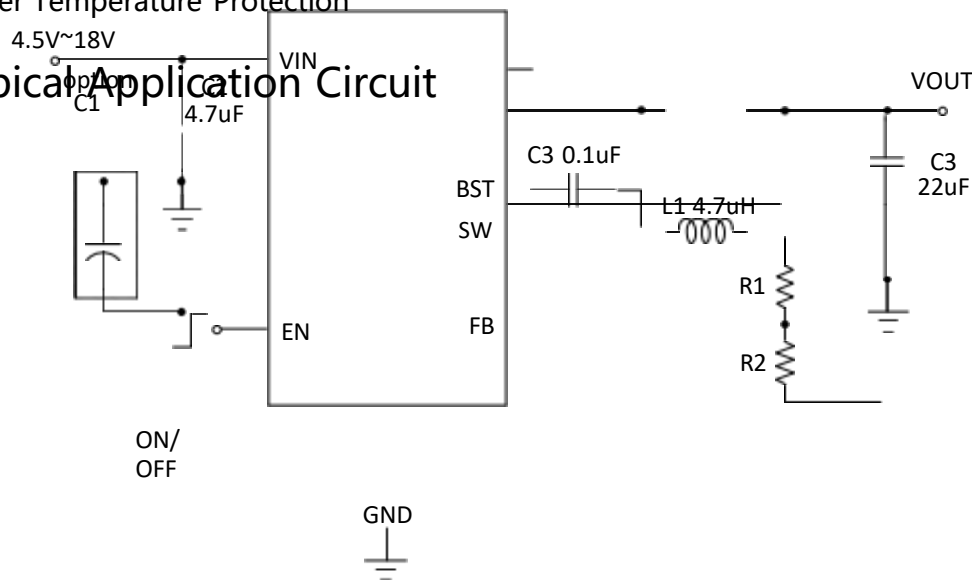

Note: The application scenario is that the DC power supply is directly plugged in, and it is recommended to add electrolytic capacitance at the input.

4 General Description

The XP3182 is a high frequency, synchronous buck converter with internal power MOSFET. XP3182 supports wide input voltage range: 4.5V to 20V and provides 2.0A continuous load current capability, and provide high efficiency without use of external Schottky diode. Low output voltage ripple and small external inductor and capacitor size are achieved with 600KHz switching frequency

XP3182 has a variety of protection functions: Input over voltage protection, Input UVLO, Output over current protection, Output short protection and thermal shutdown.

The XP3182 is available in a 6-pin SOT23-6 package, which provides a compact solution with minimal external components.

5 Pin Description

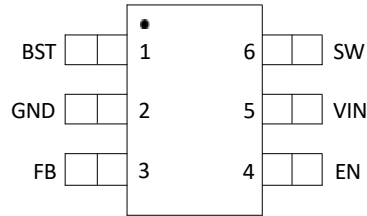

XP3182 (top view)

Pin	Name	Function
1	BST	Bootstrap. A capacitor connected between SW and BST pins is required to form a floating supply across the high-side switch driver
2	GND	Ground
3	FB	Output Voltage feedback input
4	EN	Drive this pin to a logic-high to enable the IC. Drive to a logic-low to disable the IC and enter micro-power shutdown mode
5	VIN	Power Supply Pin
6	SW	Switching Pin

6 Ordering Information

Part Number	Mark	Specification	Package
XP3182	3182 XXXX		SOT23-6

Mark description:

First line, 3182: Device Code:

Second line, XXXX: Lot Number.

7 Specification

7.1 Limit Operating Parameter ⁽¹⁾

Parameter	Min	Max	Unit
V _{IN}	-0.3	20	V
V _{SW}	-0.3	V _{IN}	V
V _{BST}	V _{SW} -0.3	V _{SW} +6	V
V _{FB}	-0.3	6	V
V _{EN}	-0.3	20	V
T _J	-40	150	°C
T _{STG}	-40	150	°C

(1) Permanent device damage may occur if Absolute Maximum Ratings are exceeded.

7.2 ESD Rating

Items	Description	Value	Unit
V _{ESDHBM}	Human Body Model for all pin	±2000	V

ESD test base on Human Body Model.

7.3 Recommended Operating Conditons

Parameter	Min	Typ	Max	Unit
V _{IN}	4.5	12	18	V
L		4.7		μH
C _{IN}		4.7		μF
C _{OUT}		22		μF
T _A	-40		85	°C

7.4 Thermal Information

Parameter	Description	Value	Unit
R _{θJA}	Junction-to-ambient thermal resistance	170	°C/W

7.5 Electrical Characteristics

$V_{IN}=12V$, $V_{OUT}=5V$, $L=4.7\mu H$, $T_a=25^\circ C$, unless other notes

Parameters	Symbol	Condition	Min	Typ	Max	Unit
VIN Under Voltage Current	I_{UVLO}	$V_{IN}=4V$		80		μA
Quiescent Current	I_{NOSW}	$V_{IN}=12V$		500		μA
Supply Current in Shutdown	I_{SD}	$V_{EN}=0$ or $V_{EN}=GND$		1		μA
FB Voltage Reference	V_{FB}			0.6		V
Minimum Turn-on Voltage	V_{UVLO}			4		V
Maximum Turn-on Voltage	V_{INOVP}			20		V
High-Side Switch On-Resistance	$R_{DS_{ON_H}}$			100		$m\Omega$
Low-Side Switch On-Resistance	$R_{DS_{ON_L}}$			70		$m\Omega$
Frequency	F_{OSC}			600		kHz
Maximum Duty Cycle	D_{MAX}			95		%
Minimum On Time	T_{ON}			100		ns
Minimum On Time	T_{OFF}			200		ns
Valley Current Limit	I_{CC}			2.5		A
Soft Start Time	T_{SS}			2		mS
Hiccup Time	T_{HICCUP}			120		mS
OTP	T_{SD}			150		$^\circ C$

8 Detailed Description

8.1 Setting the output voltage

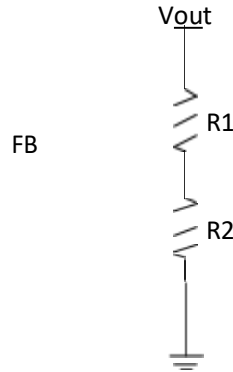

Set the output voltage

The connection above shows the setting of the output voltage. The FB voltage is 0.6V, The external resistor divider is used to set the output voltage. R1, R2 is given by:

$$V_{OUT} = 0.6V * (R1 + R2) / R2$$

Vout	R1(KΩ)	R2(KΩ)
5V	100	13.6
3.3V	100	22
1.8V	100	50
1.2V	100	100

8.2 Selecting the inductor

For highest efficiency, the inductor DC resistance should be as low as possible. The recommended inductor values are shown in the application diagram. It is important to ensure that the inductor is not saturated in any situation.

$$L = V_{OUT} * (V_{IN} - V_{OUT}) / (V_{IN} * \Delta I_L * f_{OSC})$$

Where V_{IN} is the input voltage, V_{OUT} is the output voltage, f_{OSC} is the switching frequency, and ΔI_L is the peak-to-peak inductor ripple current.

8.3 Layout Guide

1. Input capacitance and high frequency decoupling small capacitors should be as close to the input pins as possible to improve filtering effect.
2. Inductor should be as close to the SW pin to reduce electromagnetic noise.
3. Output capacitance C_{OUT} should be as close to inductor.
4. Vout , SW away from sensitive analog areas such as FB.

9 Package Information

